

Yuasa Technisches Datenblatt

Yuasa M27-EFB - Schiffsbatterien

Leistung

Spannung	12V
Kapazität 20 Std (vorgegeben)	90Ah
Kaltstartstrom (A) EN1	700A
Marine Cranking Amps (MCA)	840A
Watt Hour	1080Wh

Abmessungen

Länge	304mm
Breite	173mm
Höhe	225mm



Maße und Gewichte

Durchschnittliches Gewicht inkl. Säure	22.3kg
--	--------

Gehäuseeigenschaften

Gehäusotyp	GR27 BCI
Zellenanordnung	1
Batteriehälter	B1
Ladezustandsanzeige	✓
Tragegriffe	✓
Entgasung	✓
Semi Traktionseigenschaften	✓
Deckeltyp	SMF doppelwandige Deckelkonstruktion

Technologie

Flammschutz	✓
Technologie	Ca/Ca
Adskiller	PE
Empfohlener Ladestrom	6A

Anschlusspol Typ

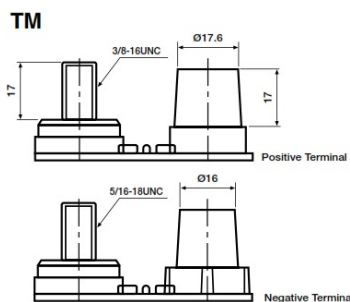

Zellenanordnung

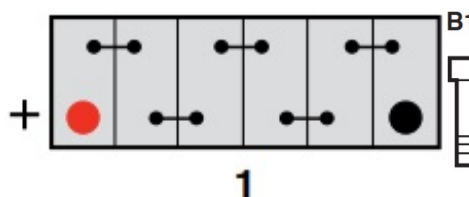

Batteriehälter

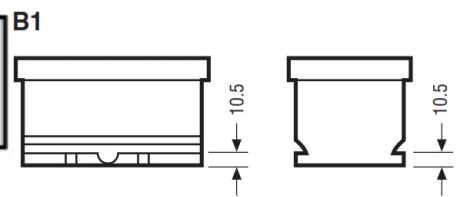

Datenblatt erstellt am 21/03/2025 - E&EO



Yuasa Technical Data Sheet

Yuasa M27-EFB - Marine Batteries

Performance

Voltage	12V
Capacity (20-hour)	90Ah
Cold Cranking Amps (EN1)	700A
Marine Cranking Amps (MCA)	840A
Watt Hour	1080Wh

Dimensions

Length	304mm
Width	173mm
Height	225mm



Weights & Measures

Mean Weight with Acid	22.3kg
-----------------------	--------

Container Features

Case Type	GR27 BCI
Cell Layout	1
Hold Down	B1
State of Charge Indicator	✓
Handles	✓
End Venting	✓
Semi-Traction Features	✓
Lid Type	SMF Double Lid

Technology

Flame Arrestor	✓
Technology	Ca/Ca
Separator	PE
Recommended Charge Rate	6A

Terminal Type

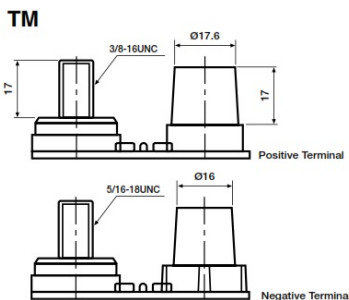

Cell Assembly Layout

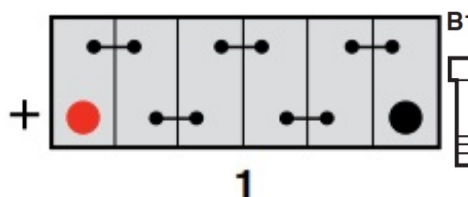

Battery Hold-down

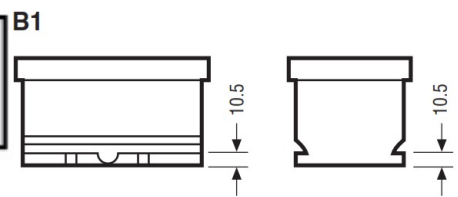

Data Sheet generated on 21/03/2025 - E&OE