

**Qty. Description**

1 SBA 3-45 A



**Note! Product picture may differ from actual product**

Product No.: On request

Grundfos SBA 3-45 A is an all-in-one submersible booster designed for pumping clean water for domestic use. The SBA is built on the proven SB platform and comes with an integrated control unit. This eliminates the need for an external pump controller in the house. It is silent when submerged and therefore a noiseless alternative to surface-mounted pumps. The pump is built from high quality composite and stainless steel materials that are resistant to corrosion.

The SBA 3-45 A is equipped with a 15 m supply cable, and the maximum installation depth is 10 m below the water level, with a liquid temperature ranging from 0 °C to 40 °C.

The pump starts automatically when the pipe pressure falls below 2.2 bar.

The SBA 3-45 A is ideal for operation in a well or ground tanks, as it easily prevents solid particles from entering the pump. The maximum particle size is 1 mm.

The single-phase model is effectively protected against any accidental overload by built-in thermal protection.

The pump has built-in thermal protection, which immediately stops the pump if it overheats. Having cooled down, the pump automatically restarts when it reaches a normal temperature.

**Controls:**

Float switch (Yes/No): Y

**Liquid:**

Pumped liquid: Water  
 Liquid temperature range: 0 .. 40 °C  
 Selected liquid temperature: 20 °C  
 Density: 998.2 kg/m<sup>3</sup>

**Technical:**

Rated flow: 3 m<sup>3</sup>/h  
 Rated head: 32.6 m  
 Max. Particle: 1 mm  
 Approvals: CE  
 Curve tolerance: ISO9906:2012 3B  
 Return valve: YES  
 Adjustable start pressure (Yes/No): N  
 Start pressure: 2.2 bar

**Materials:**

**Qty. Description**

1	<p>Pump housing: Composite PP - GF30</p> <p>Impeller: Composite PPO-20GF</p> <p>Installation: Range of ambient temperature: -10 .. 50 °C Type of inlet connection: STRAINER Pump outlet: G 1" Pressure rating for connection: PN 6 Maximum installation depth: 10 m</p> <p>Electrical data: Power input P1: 0.9 kW Rated power - P2: 0.55 kW Mains frequency: 50 Hz Rated voltage: 1 x 220-240 V Rated current: 4 A Starting current: 12 A Cos phi: 0.951 Rated speed: 2800 rpm Capacitor size - run: 12 µF/450 V Enclosure class (IEC 34-5): X8 Insulation class (IEC 85): F Built-in motor protection: YES Length of cable: 15 m Cable type: H07RN-F 3G1 Type of cable plug: SCHUKO</p> <p>Others: Net weight: 13.2 kg Gross weight: 14.2 kg Shipping volume: 0.04 m<sup>3</sup> Danish VVS No.: 391367245 Swedish RSK No.: 5858011 Finnish LVI No.: 4822622 Norwegian NRF no.: 9040076 Country of origin: IT Custom tariff no.: 84137029</p>
---	---

## On request SBA 3-45 A 50 Hz

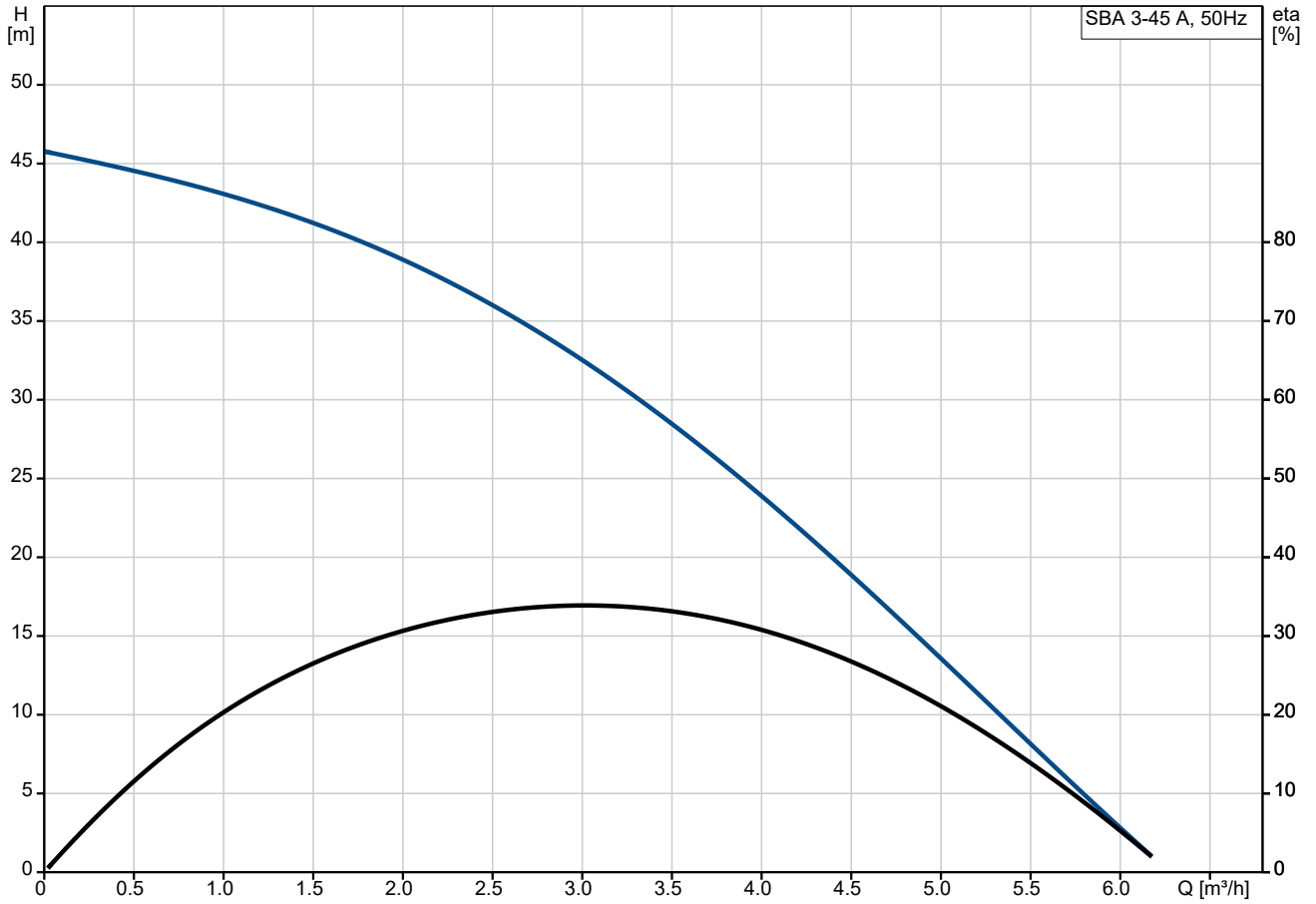

Pumped liquid = Water  
 Liquid temperature during operation = 20 °C  
 Density = 998.2 kg/m³

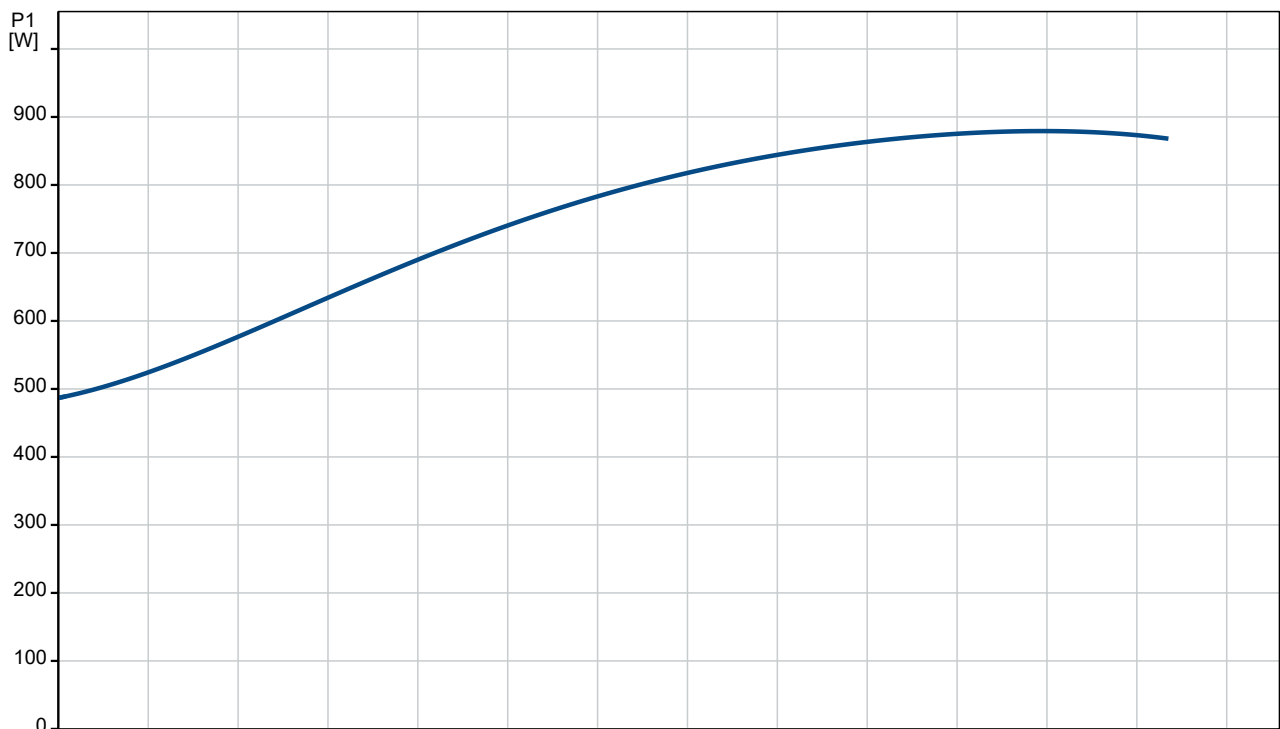

Description	Value
<b>General information:</b>	
Product name:	SBA 3-45 A
Product No:	On request
EAN number:	On request
<b>Technical:</b>	
Rated flow:	3 m <sup>3</sup> /h
Rated head:	32.6 m
Maximum head:	45 m
Impellers:	3
Max. Particle:	1 mm
Approvals:	CE
Curve tolerance:	ISO9906:2012 3B
Return valve:	YES
Adjustable start pressure (Yes/No):	N
Start pressure:	2.2 bar
<b>Materials:</b>	
Pump housing:	Composite
Pump housing:	PP - GF30
Impeller:	Composite
Impeller:	PPO-20GF
<b>Installation:</b>	
Range of ambient temperature:	-10 .. 50 °C
Type of inlet connection:	STRAINER
Pump outlet:	G 1"
Pressure rating for connection:	PN 6
Maximum installation depth:	10 m
<b>Liquid:</b>	
Pumped liquid:	Water
Liquid temperature range:	0 .. 40 °C
Selected liquid temperature:	20 °C
Density:	998.2 kg/m <sup>3</sup>
pH-value range:	4-9
<b>Electrical data:</b>	
Power input P1:	0.9 kW
Rated power - P2:	0.55 kW
Mains frequency:	50 Hz
Rated voltage:	1 x 220-240 V
Rated current:	4 A
Starting current:	12 A
Cos phi:	0.951
Rated speed:	2800 rpm
Capacitor size - run:	12 µF/450 V
Enclosure class (IEC 34-5):	X8
Insulation class (IEC 85):	F
Built-in motor protection:	YES
Length of cable:	15 m
Cable type:	H07RN-F 3G1
Type of cable plug:	SCHUKO
<b>Controls:</b>	
Float switch (Yes/No):	Y
<b>Others:</b>	
Net weight:	13.2 kg
Gross weight:	14.2 kg
Shipping volume:	0.04 m <sup>3</sup>
Danish VVS No.:	391367245
Swedish RSK No.:	5858011
Finnish LVI No.:	4822622
Norwegian NRF no.:	9040076

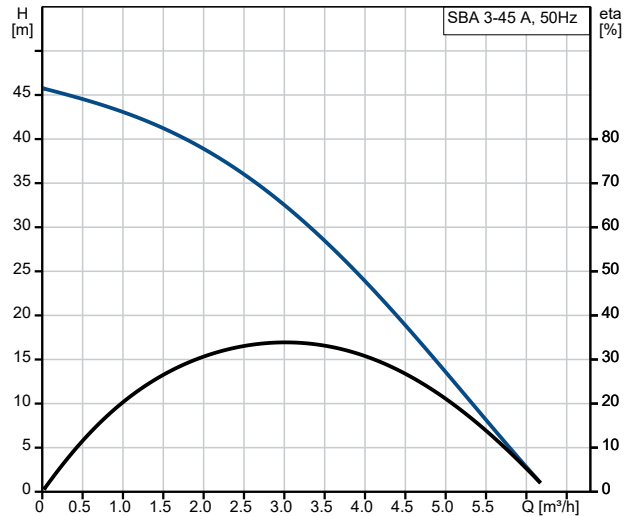

Pumped liquid = Water  
 Liquid temperature during operation = 20 °C  
 Density = 998.2 kg/m<sup>3</sup>

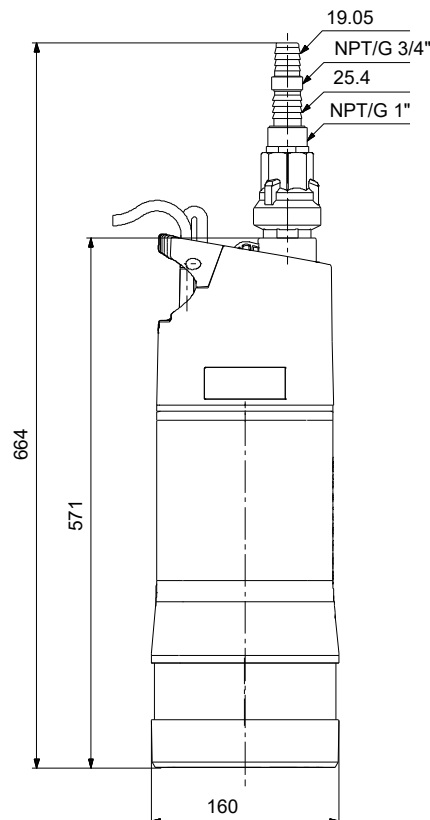
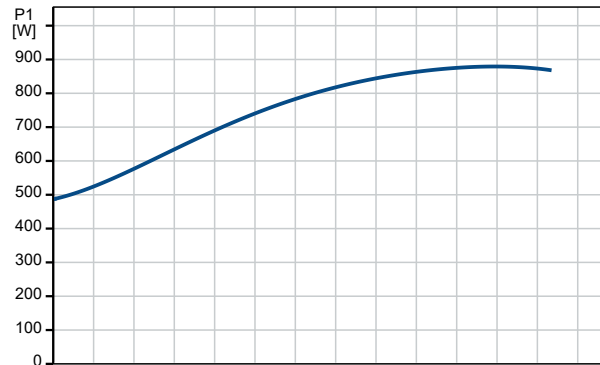



Company name:

Created by:

Phone:

Date:

28/11/2023

Description	Value
Country of origin:	IT
Custom tariff no.:	84137029

**On request SBA 3-45 A 50 Hz**

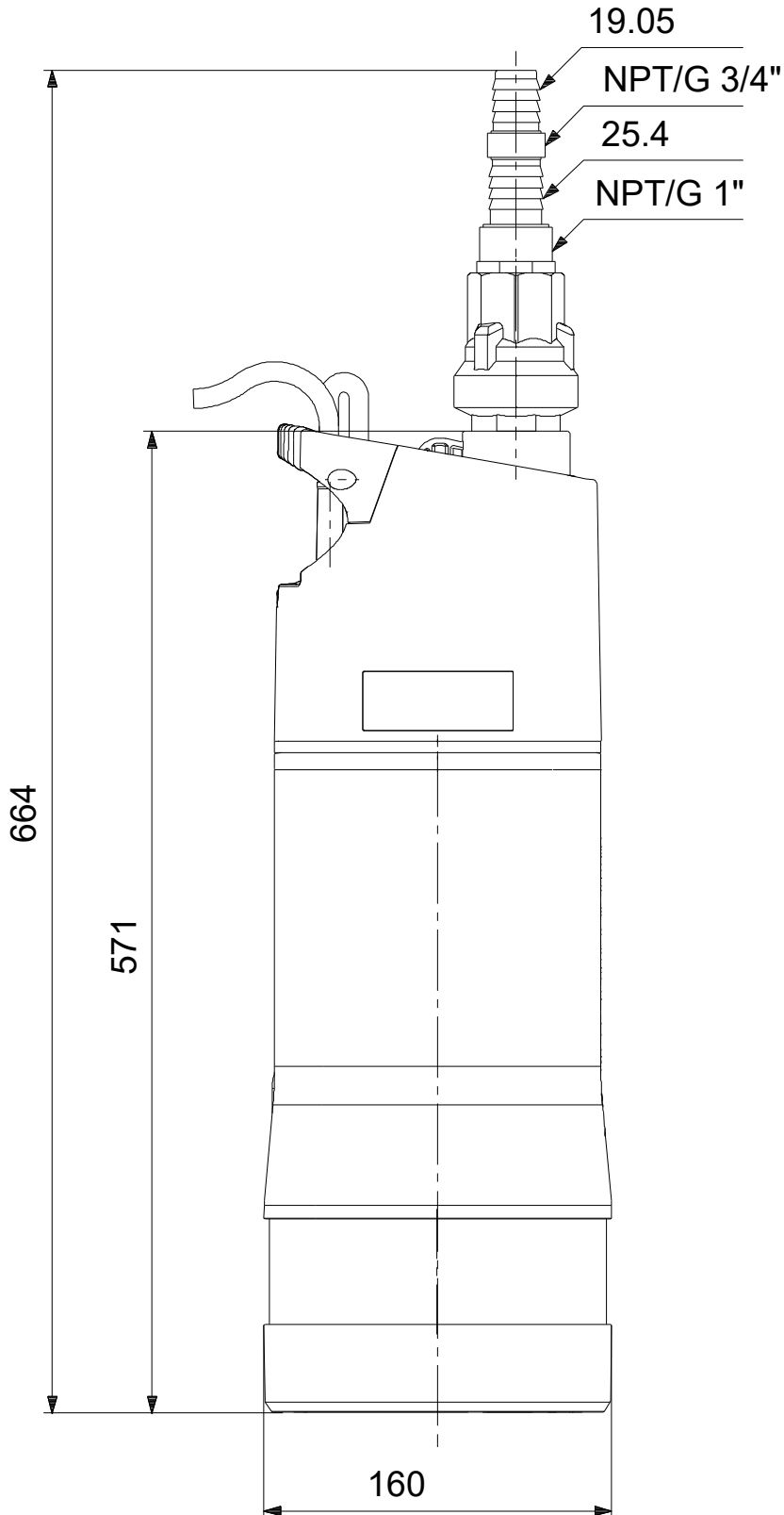

Note! All units are in [mm] unless others are stated.  
Disclaimer: This simplified dimensional drawing does not show all details.

