

# Submittal Data

PROJECT:	UNIT TAG:	QUANTITY:
REPRESENTATIVE: _____	TYPE OF SERVICE:	DATE: _____
ENGINEER:	SUBMITTED BY:	DATE:
CONTRACTOR:	APPROVED BY:	DATE:
	ORDER NO.:	DATE:



## NBGE 125-100-160/176 BIASF2KESBQQERW1

End-suction close-coupled pumps according to ISO 2858 with frequency-controlled motors.

Note! Product picture may differ from actual product

Conditions of Service	Pump Data	Motor Data
Liquid: Water	Liquid temperature range: -25 .. 120 °C	Rated voltage: 380-420D/660-725Y V
Temperature: 20 °C	Maximum ambient temperature: 50 °C	Mains frequency: 50 Hz
Specific Gravity: 1.000	Shaft seal: BQQE	Enclosure class: IP55
	Product number: On request	Insulation class: F
		Motor protection: PTC
		Eta 1/1: 94.5 %

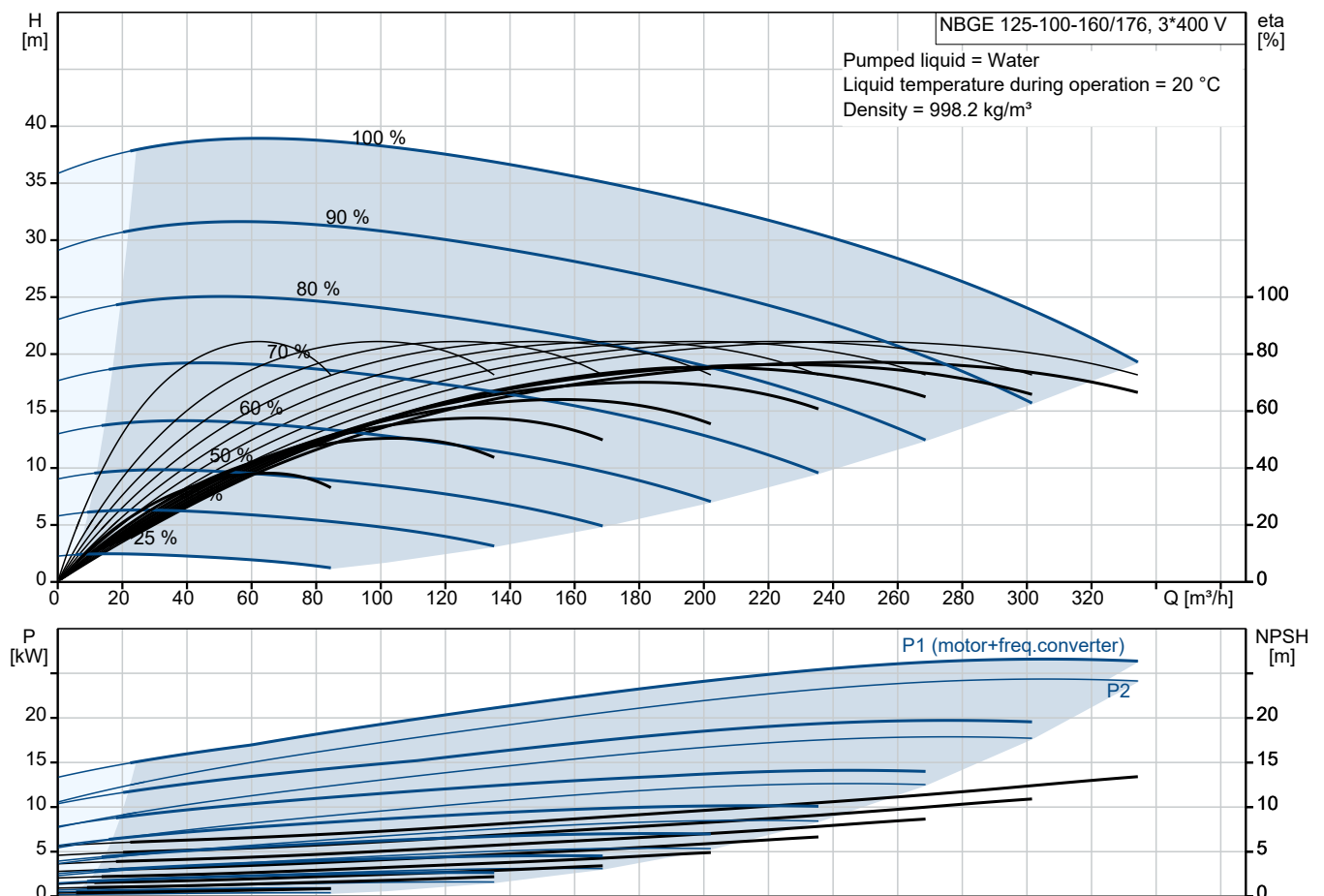

# Submittal Data

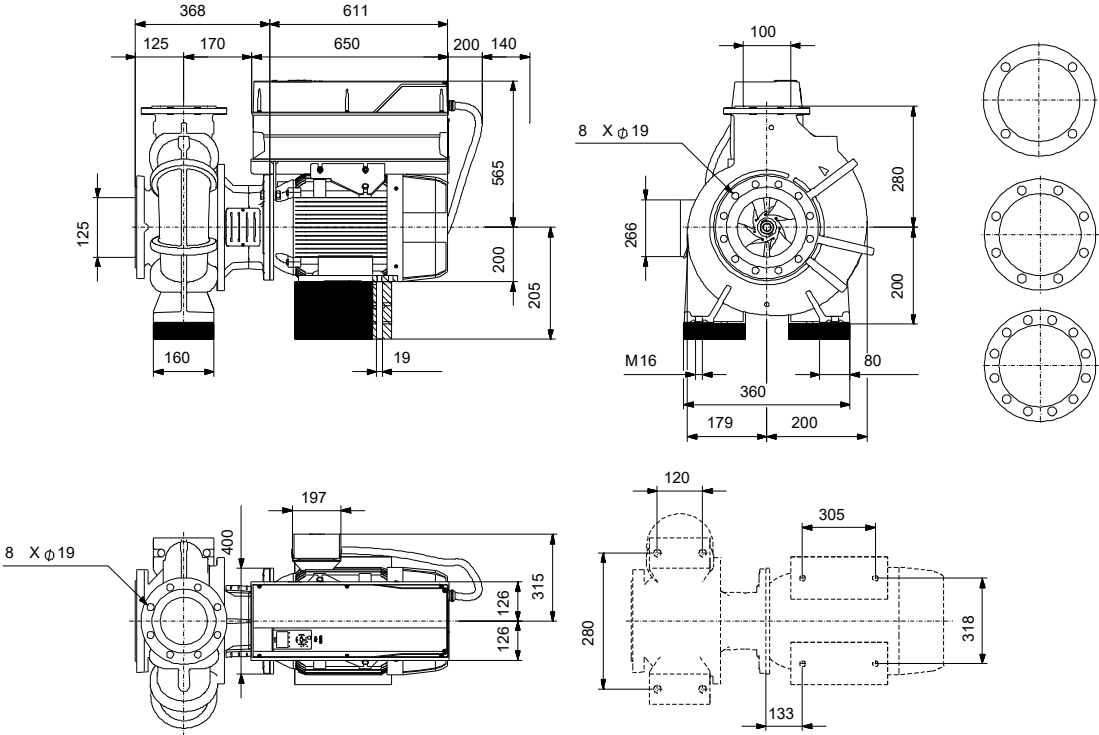

**Materials:**  
 Pump housing: Stainless steel  
 Pump housing: ASTM CF8M  
 Impeller: Stainless steel  
 Impeller: ASTM CF8M  
 Impeller: EN 1.4408  
 Material code: K  
 Code for rubber: E

Qty. Description

1 NBGE 125-100-160/176 BIASF2KESBQQERW1



Note! Product picture may differ from actual product

Product No.: On request

Non-self-priming, single-stage, centrifugal volute pump designed according to ISO 5199 with dimensions and rated performance according to ISO 2858 (16 bar). Flanges are PN 16 with dimensions according to EN 1092-1. The pump has an axial suction port, radial discharge port, horizontal shaft and a back pull-out design enabling removal of the motor, motor stool, cover and impeller without disturbing the pump housing or pipework.

The unbalanced rubber bellows seal is according to DIN EN 12756.

The pump is close-coupled to a fan-cooled asynchronous motor.

The product's minimum efficiency index (MEI) is greater or equal to 0.70. This is by the Commission Regulation (EU) considered as an indicative benchmark for best-performing water pump available on the market as from 1 January 2013.

The back pull-out design means that the pump can be serviced by a single person without disturbing the pump housing or pipes.

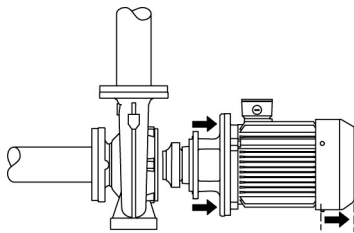

## Pump

The pump housing has both a priming and a drain hole closed by plugs. The impeller is a closed impeller with double-curved blades with smooth surfaces. The impeller is statically balanced according to ISO 1940-1 class G6.3 and hydraulically balanced to compensate for axial thrust.

The motor stool is made of cast iron (EN-GJL-250) and the pump cover is made of stainless steel (EN 1.4408). Coupling guards are fitted to the motor stool.

The pump is fitted with an unbalanced rubber bellows seal with torque transmission across the spring and around the bellows. Due to the bellows, the seal does not wear the shaft, and the axial movement is not prevented by deposits on the shaft.

Seal faces:

- Rotating seal ring material: silicon carbide (SiC)
- Stationary seat material: silicon carbide (SiC)

This material pairing is used where higher corrosion resistance is required. The high hardness of this material pairing offers good resistance against abrasive particles.

Secondary seal material: EPDM (ethylene-propylene rubber)

EPDM has excellent resistance to hot water. EPDM is not suitable for mineral oils.

The pump housing has feet.

The pump is to be secured to the foundation with bolts through the pump housing feet and motor feet. The pump is delivered with steel support blocks. The support blocks provide horizontal alignment of the pump and ensure clearance between the motor stool/motor flange and the foundation.

The pump has loose flanges.

The loose flanges are made of cast iron (EN-GJS-500-7/ASTM 70-50-05).

The language on the pump nameplate is English.

**Qty. Description**

1

**Motor**

The motor is a totally enclosed, fan-cooled motor with principal dimensions to IEC and DIN standards. Electrical tolerances comply with IEC 60034.

The motor efficiency is classified as IE4 in accordance with IEC 60034-30-1.

The motor has thermistors (PTC sensors) in the windings in accordance with DIN 44081/DIN 44082. The protection reacts to both slow- and quick-rising temperatures, e.g. constant overload and stalled conditions.

Thermal switches must be connected to an external control circuit in a way which ensures that the automatic reset cannot cause accidents. The motors must be connected to a motor-protective circuit breaker according to local regulations.

The motor requires no external motor protection. The motor control unit incorporates protection against slow- and quick-rising temperatures, e.g. constant overload and stalled conditions.

**Further product details**

**Technical data**

Controls:

VFD product number: 99616823

Frequency converter: Built-in

Type of frequency converter: CUE 3X380-500V IP55 RUG 30KW

Appr. for VFD: CE, CULUS, C-TICK

Pressure sensor: N

Liquid:

Pumped liquid: Water

Liquid temperature range: -25 .. 120 °C

Selected liquid temperature: 20 °C

Density: 998.2 kg/m<sup>3</sup>

Technical:

Pump speed on which pump data are based: 2955 rpm

Rated flow: 244.2 m<sup>3</sup>/h

Rated head: 29.59 m

Actual impeller diameter: 176 mm

Nominal impeller diameter: 160

Type of impeller: Standard

Shaft seal arrangement: Single

Code for shaft seal: BQQE

Curve tolerance: ISO9906:2012 3B

Bearing design: Standard

Materials:

Pump housing: Stainless steel

EN 1.4408

ASTM CF8M

Wear ring: Stainless steel

Flange: Cast iron

EN-GJS-500-7

ASTM 70-50-05

Impeller: Stainless steel

EN 1.4408

ASTM CF8M

Internal pump house coating: No coating

Shaft: Stainless steel

EN 1.4401

AISI 316

Qty.	Description
------	-------------

1	<p>Installation:</p> <p>Range of ambient temperature: -10 .. 50 °C</p> <p>Maximum operating pressure: 16 bar</p> <p>Pipe connection standard: EN 1092-1</p> <p>Size of inlet connection: DN 125</p> <p>Size of outlet connection: DN 100</p> <p>Pressure rating for connection: PN 16</p> <p>Bearing lubrication: Grease</p> <p>Pump housing with feet: Yes</p> <p>Support block (Yes/No): Y</p> <p>Electrical data:</p> <p>Rated power - P2: 30 kW</p> <p>Mains frequency: 50 Hz</p> <p>Rated voltage: 3 x 380-420D/660-725 V</p> <p>Rated current: 54/31.5 A</p> <p>Starting current: 790 %</p> <p>Cos phi - power factor: 0.85</p> <p>Rated speed: 2955 rpm</p> <p>IE efficiency: IE4 94,5%</p> <p>IE Efficiency class: IE4</p> <p>Motor efficiency at full load: 94.5 %</p> <p>Motor efficiency at 3/4 load: 94.8 %</p> <p>Motor efficiency at 1/2 load: 94.4 %</p> <p>Number of poles: 2</p> <p>Enclosure class (IEC 34-5): IP55</p> <p>Insulation class (IEC 85): F</p> <p>Motor No: 92779349</p> <p>Bearing insulation type N-end: COATED RING</p> <p>Others:</p> <p>Minimum efficiency index, MEI ≥: 0.70</p> <p>Net weight: 365 kg</p> <p>Gross weight: 446 kg</p> <p>Shipping volume: 1.6 m<sup>3</sup></p> <p>Country of origin: HU</p> <p>Custom tariff no.: 84137051</p> <p>Language on pump nameplate: GB</p>
---	---

## On request NBGE 125-100-160/176 BIASF2KESBQQERW1 50 Hz

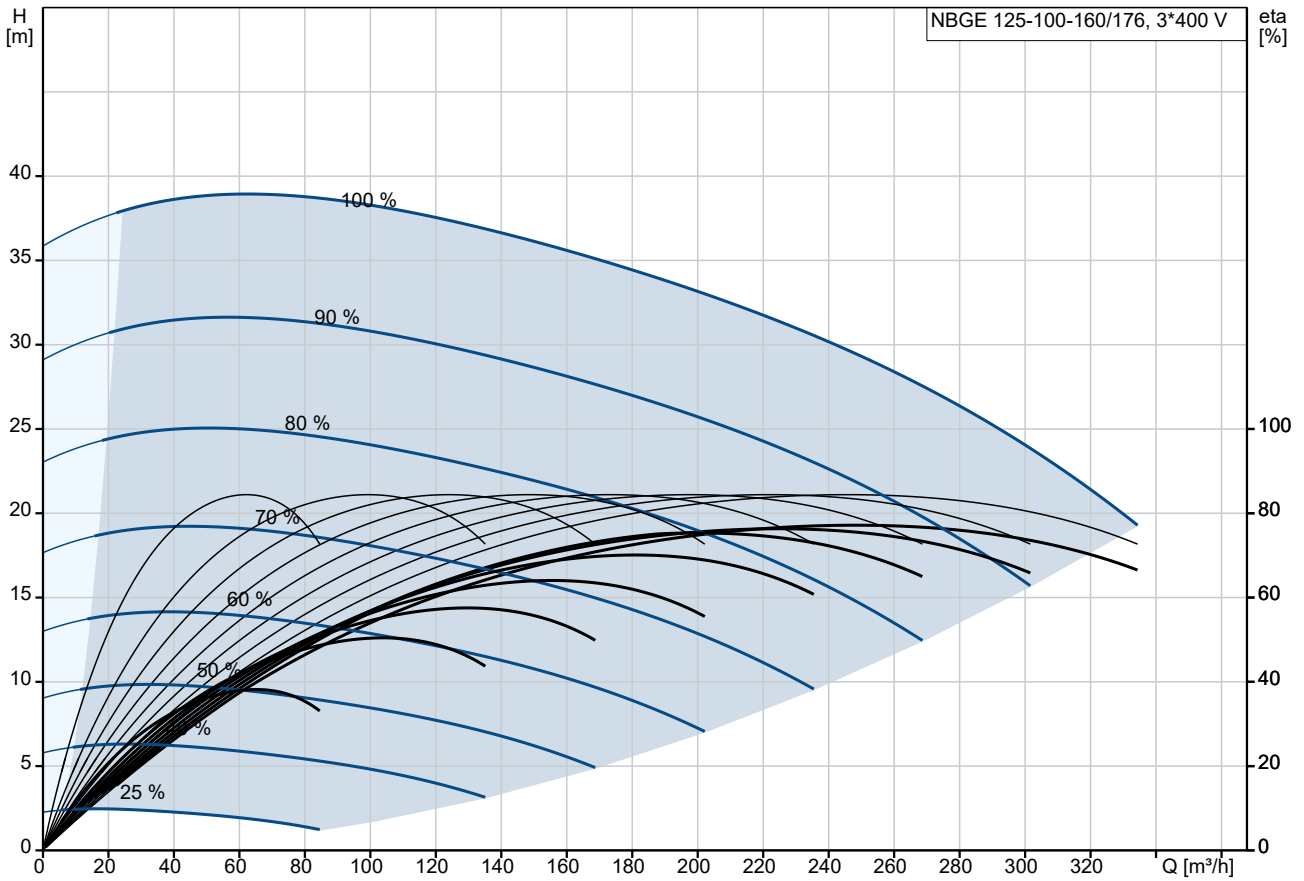

Pumped liquid = Water  
 Liquid temperature during operation = 20 °C  
 Density = 998.2 kg/m³

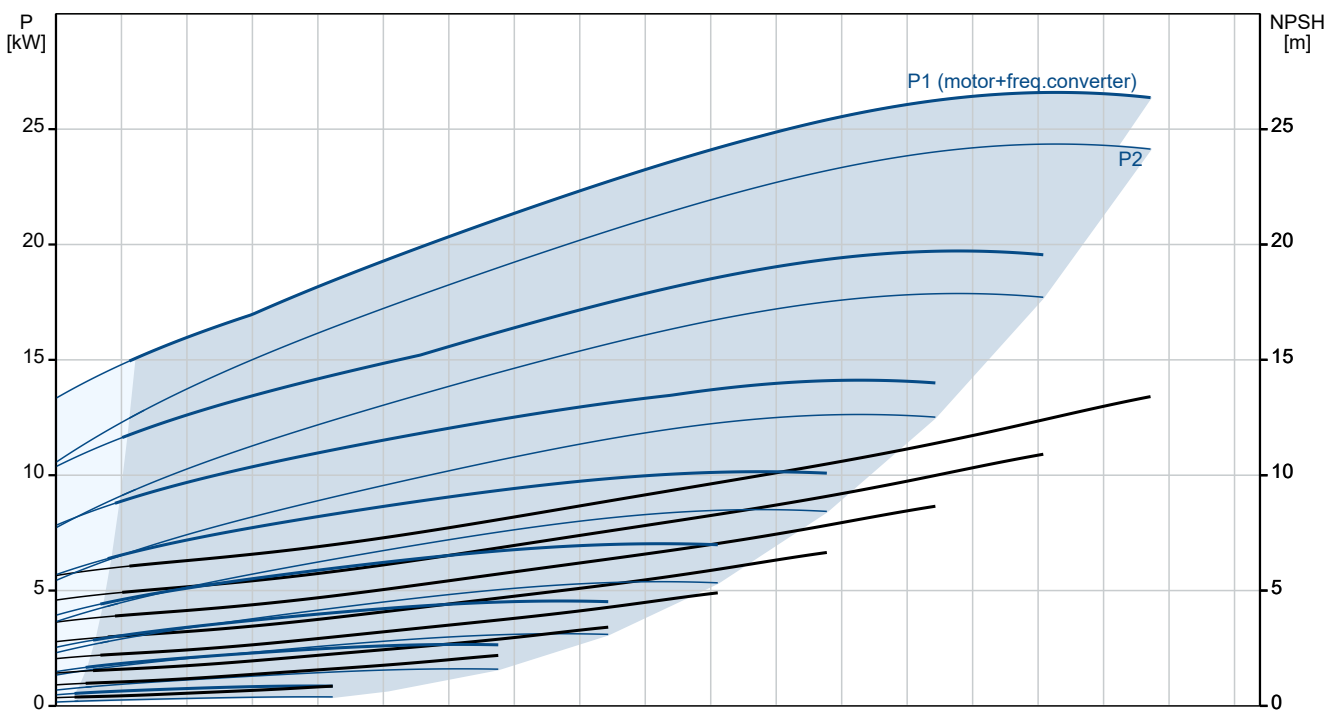





Company name:

Created by:

Phone:

Date:

24/10/2024

Description	Value
Cos phi - power factor:	0.85
Rated speed:	2955 rpm
IE efficiency:	IE4 94,5%
IE Efficiency class:	IE4
Motor efficiency at full load:	94.5 %
Motor efficiency at 3/4 load:	94.8 %
Motor efficiency at 1/2 load:	94.4 %
Number of poles:	2
Enclosure class (IEC 34-5):	IP55
Insulation class (IEC 85):	F
Built-in motor protection:	PTC
Motor No:	92779349
Mount. design. acc. IEC 34-7:	IM B35
Bearing insulation type N-end:	COATED RING
<b>Controls:</b>	
VFD product number:	99616823
Frequency converter:	Built-in
Type of frequency converter:	CUE 3X380-500V IP55 RUG 30KW
Appr. for VFD:	CE, CULUS, C-TICK
Pressure sensor:	N
<b>Others:</b>	
Minimum efficiency index, MEI ≥:	0.70
Net weight:	365 kg
Gross weight:	446 kg
Shipping volume:	1.6 m <sup>3</sup>
Country of origin:	HU
Custom tariff no.:	84137051
Language on pump nameplate:	GB

## On request NBGE 125-100-160/176 BIASF2KESBQQERW1 50 Hz

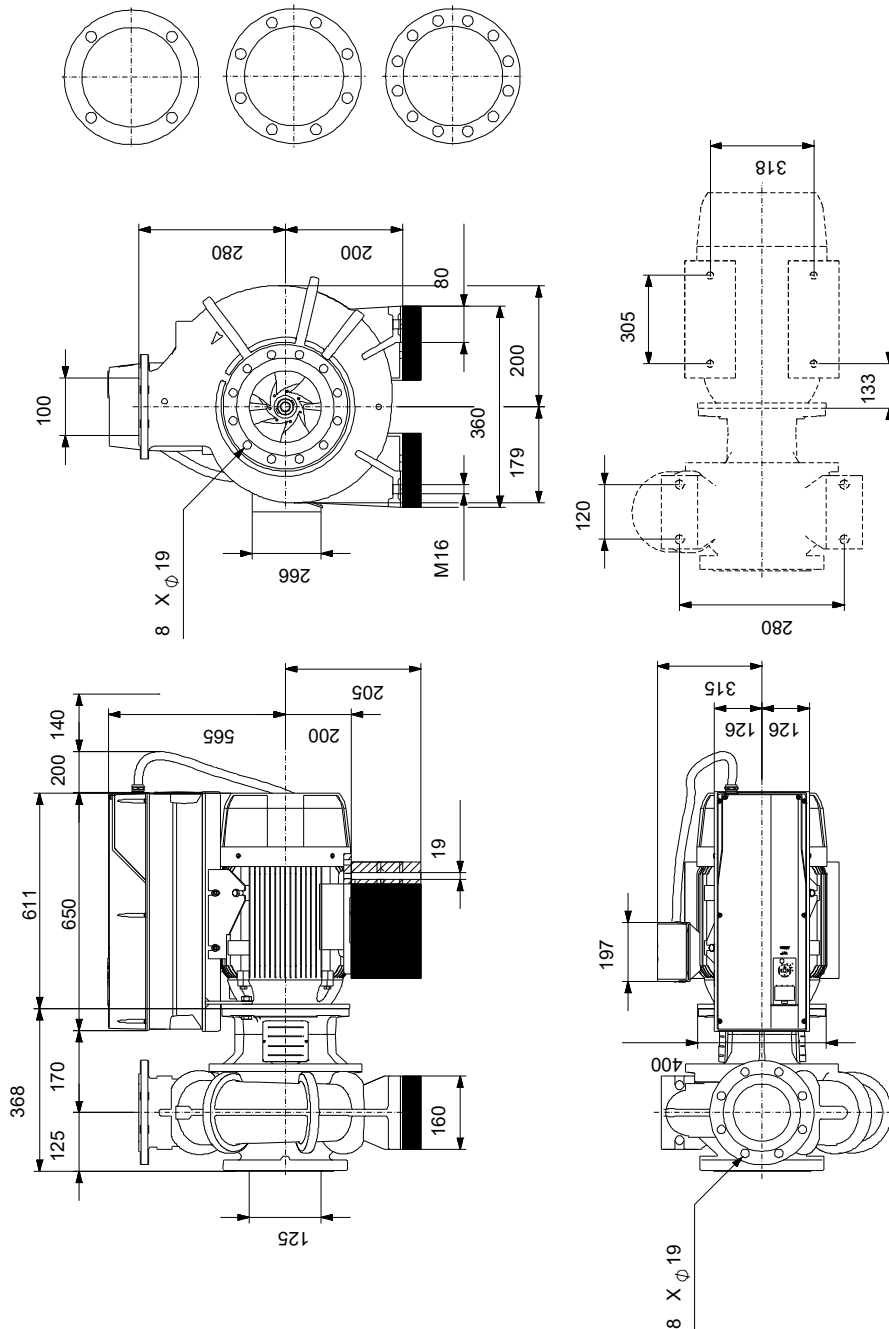

Note! All units are in [mm] unless others are stated.  
Disclaimer: This simplified dimensional drawing does not show all details.

## On request NBGE 125-100-160/176 BIASF2KESBQQERW1 50 Hz

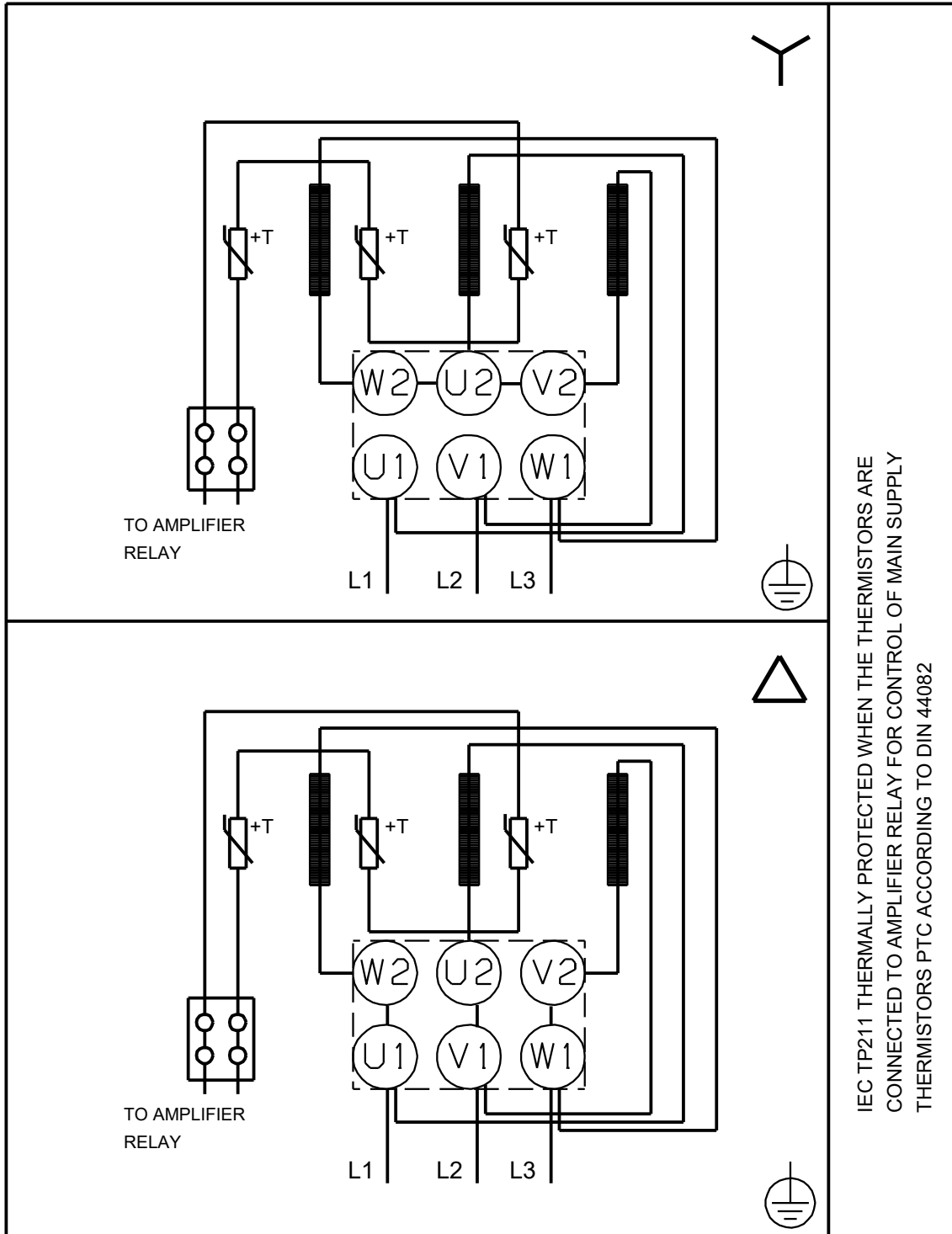

IEC TP211 THERMALLY PROTECTED WHEN THE THERMISTORS ARE  
CONNECTED TO AMPLIFIER RELAY FOR CONTROL OF MAIN SUPPLY  
THERMISTORS PTC ACCORDING TO DIN 44082

Note! All units are in [mm] unless others are stated.

