

Submittal Data

PROJECT:	UNIT TAG:	QUANTITY:
REPRESENTATIVE: _____	TYPE OF SERVICE:	DATE: _____
ENGINEER:	SUBMITTED BY:	DATE:
CONTRACTOR:	APPROVED BY:	DATE:
	ORDER NO.:	DATE:



NBGE 200-150-315.2/294 AIASF2LVSBQQVSW3

End-suction close-coupled pumps according to ISO 2858 with frequency-controlled motors.

Note! Product picture may differ from actual product

Conditions of Service		Pump Data		Motor Data	
Liquid:	Water	Liquid temperature range:	-10 .. 90 °C	Rated voltage:	380-420D/660-725Y V
Temperature:	20 °C	Maximum ambient temperature:	50 °C	Mains frequency:	50 Hz
Specific Gravity:	1.000	Shaft seal:	BQQV	Enclosure class:	IP55
		Product number:	On request	Insulation class:	F
				Motor protection:	PTC
				Eta 1/1:	95.4 %

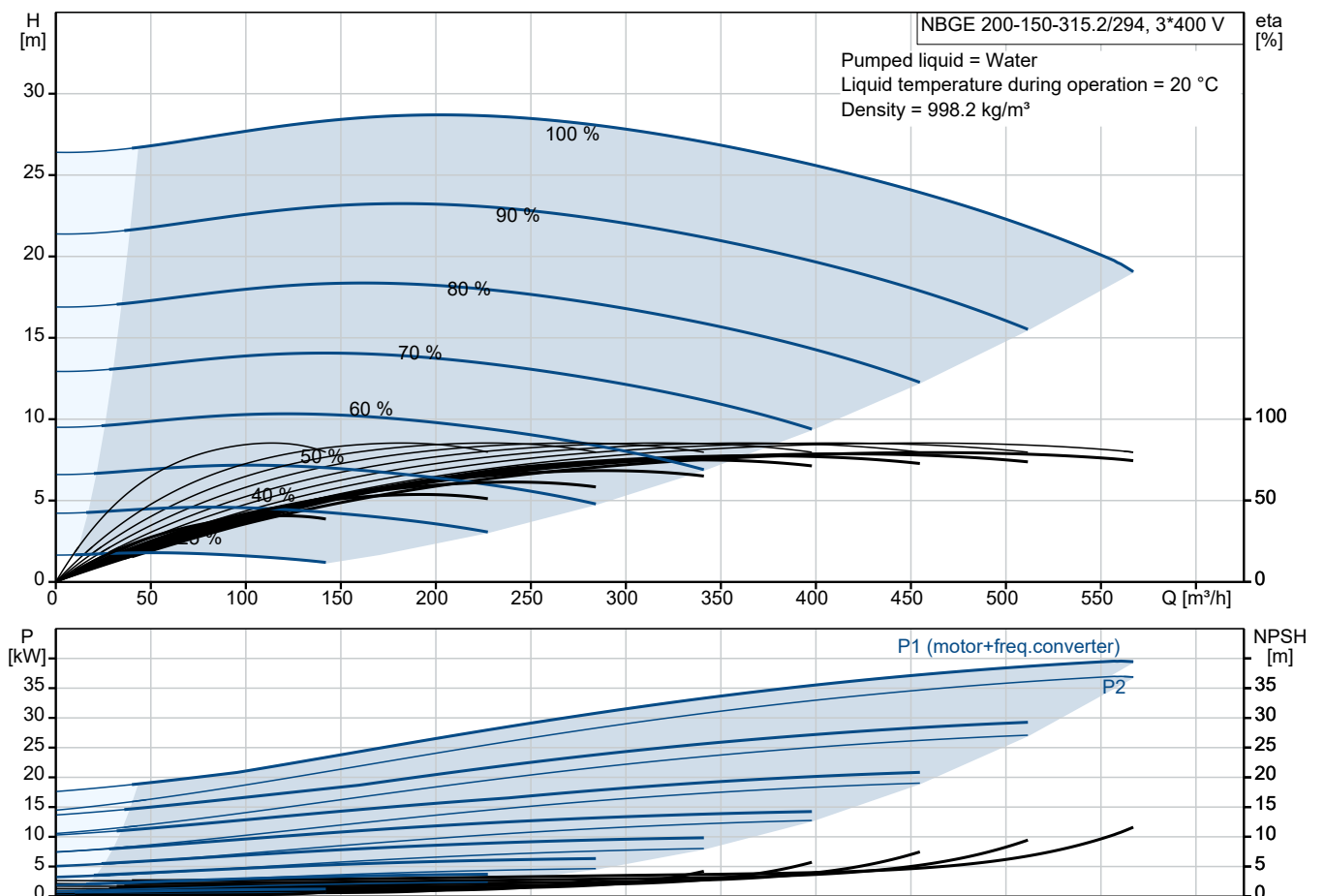

Submittal Data

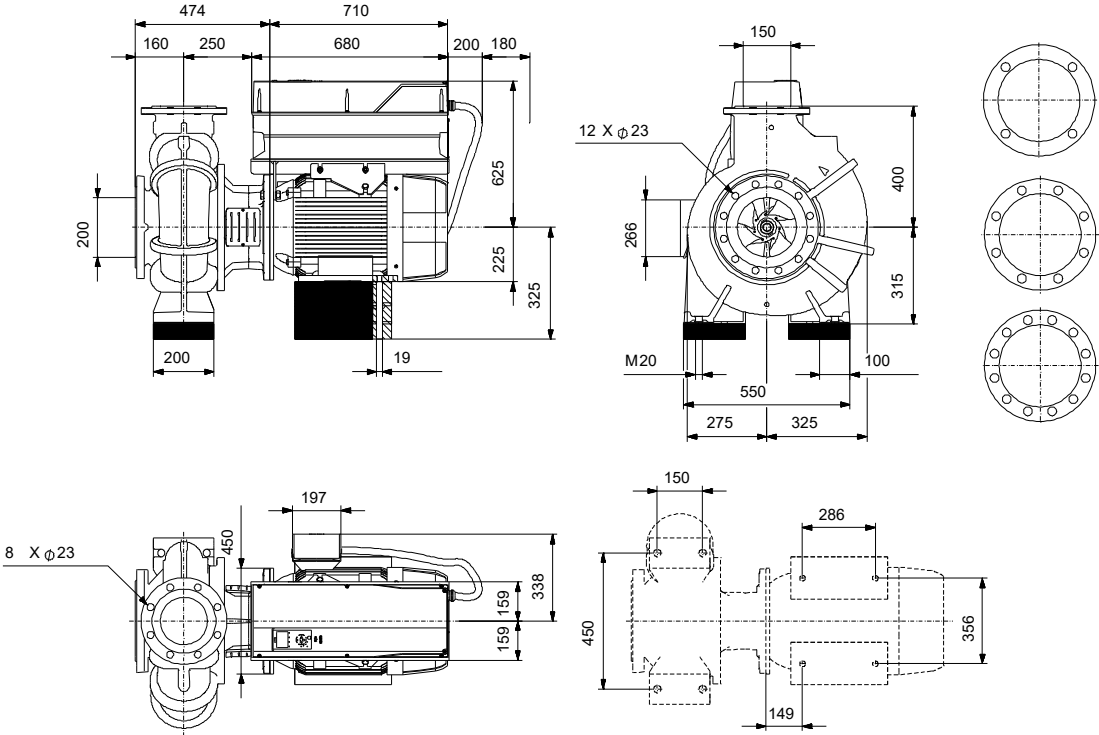

- Materials:**
- Pump housing: Stainless steel
 - Pump housing: ASTM CD4MCuN
 - Impeller: Stainless steel
 - Impeller: ASTM CD4MCuN
 - Impeller: EN 1.4517
 - Material code: L
 - Code for rubber: V

Qty. Description

1 NBGE 200-150-315.2/294 AIASF2LVSBQQVSW3



Note! Product picture may differ from actual product

Product No.: On request

Non-self-priming, single-stage, centrifugal volute pump designed according to ISO 5199 with dimensions and rated performance according to ISO 2858 (16 bar). Flanges are PN 16 with dimensions according to EN 1092-1. The pump has an axial suction port, radial discharge port, horizontal shaft and a back pull-out design enabling removal of the motor, motor stool, cover and impeller without disturbing the pump housing or pipework.

The unbalanced rubber bellows seal is according to DIN EN 12756.

The pump is close-coupled to a fan-cooled asynchronous motor.

The back pull-out design means that the pump can be serviced by a single person without disturbing the pump housing or pipes.

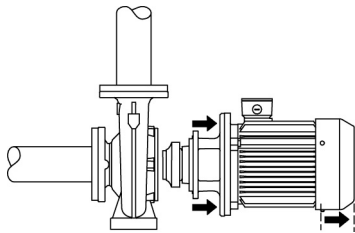

Pump

The pump housing has both a priming and a drain hole closed by plugs. The impeller is a closed impeller with double-curved blades with smooth surfaces. The impeller is statically balanced according to ISO 1940-1 class G6.3 and hydraulically balanced to compensate for axial thrust.

The motor stool is made of cast iron (EN-GJL-250) and the pump cover is made of stainless steel (EN 1.4517). Coupling guards are fitted to the motor stool.

The pump is fitted with an unbalanced rubber bellows seal with torque transmission across the spring and around the bellows. Due to the bellows, the seal does not wear the shaft, and the axial movement is not prevented by deposits on the shaft.

Seal faces:

- Rotating seal ring material: silicon carbide (SiC)
- Stationary seat material: silicon carbide (SiC)

This material pairing is used where higher corrosion resistance is required. The high hardness of this material pairing offers good resistance against abrasive particles.

Secondary seal material: FKM (fluorocarbon rubber)

FKM has excellent resistance to oils and chemicals. Above 90 °C, FKM should only be used in media without water.

The pump housing has feet.

The pump is to be secured to the foundation with bolts through the pump housing feet and motor feet. The pump is delivered with steel support blocks. The support blocks provide horizontal alignment of the pump and ensure clearance between the motor stool/motor flange and the foundation.

The pump has loose flanges.

The loose flanges are made of cast iron (EN-GJS-500-7/ASTM 70-50-05).

The language on the pump nameplate is English.

Motor

Qty.	Description
1	<p>The motor is a totally enclosed, fan-cooled motor with principal dimensions to IEC and DIN standards. Electrical tolerances comply with IEC 60034.</p> <p>The motor efficiency is classified as IE4 in accordance with IEC 60034-30-1.</p> <p>The motor has thermistors (PTC sensors) in the windings in accordance with DIN 44081/DIN 44082. The protection reacts to both slow- and quick-rising temperatures, e.g. constant overload and stalled conditions.</p> <p>Thermal switches must be connected to an external control circuit in a way which ensures that the automatic reset cannot cause accidents. The motors must be connected to a motor-protective circuit breaker according to local regulations.</p> <p>The motor requires no external motor protection. The motor control unit incorporates protection against slow- and quick-rising temperatures, e.g. constant overload and stalled conditions.</p> <p>The motor is equipped with bearing current protection. This protects the bearings from failure due to bearing currents, which can be caused e.g. by the high-frequency switching of a variable frequency drive.</p> <p>Further product details</p> <p>Technical data</p> <p>Controls:</p> <p>VFD product number: 99616824</p> <p>Frequency converter: Built-in</p> <p>Type of frequency converter: CUE 3X380-500V IP55 RUG 37KW</p> <p>Appr. for VFD: CE, CULUS, C-TICK</p> <p>Pressure sensor: N</p> <p>Liquid:</p> <p>Pumped liquid: Water</p> <p>Liquid temperature range: -10 .. 90 °C</p> <p>Selected liquid temperature: 20 °C</p> <p>Density: 998.2 kg/m³</p> <p>Technical:</p> <p>Pump speed on which pump data are based: 1485 rpm</p> <p>Rated flow: 438.4 m³/h</p> <p>Rated head: 24.44 m</p> <p>Actual impeller diameter: 294 mm</p> <p>Nominal impeller diameter: 315.2</p> <p>Type of impeller: Standard</p> <p>Shaft seal arrangement: Single</p> <p>Code for shaft seal: BQQV</p> <p>Curve tolerance: ISO9906:2012 3B</p> <p>Bearing design: Standard</p> <p>Materials:</p> <p>Pump housing: Stainless steel EN 1.4517 ASTM CD4MCuN</p> <p>Wear ring: Stainless steel</p> <p>Flange: Cast iron EN-GJS-500-7 ASTM 70-50-05</p> <p>Impeller: Stainless steel EN 1.4517 ASTM CD4MCuN</p> <p>Internal pump house coating: No coating</p> <p>Shaft: Stainless steel EN 1.4462</p>

Qty.	Description
1	<p data-bbox="564 338 675 371">SAF 2205</p> <p data-bbox="196 398 325 432">Installation:</p> <p data-bbox="196 432 691 465">Range of ambient temperature: -10 .. 50 °C</p> <p data-bbox="196 465 636 499">Maximum operating pressure: 16 bar</p> <p data-bbox="196 499 681 533">Pipe connection standard: EN 1092-1</p> <p data-bbox="196 533 649 566">Size of inlet connection: DN 200</p> <p data-bbox="196 566 649 600">Size of outlet connection: DN 150</p> <p data-bbox="196 600 636 633">Pressure rating for connection: PN 16</p> <p data-bbox="196 633 649 667">Bearing lubrication: Grease</p> <p data-bbox="196 667 608 701">Pump housing with feet: Yes</p> <p data-bbox="196 701 584 734">Support block (Yes/No): Y</p> <p data-bbox="196 745 363 779">Electrical data:</p> <p data-bbox="196 779 636 813">Rated power - P2: 37 kW</p> <p data-bbox="196 813 636 846">Mains frequency: 50 Hz</p> <p data-bbox="196 846 847 880">Rated voltage: 3 x 380-420D/660-725Y V</p> <p data-bbox="196 880 691 913">Rated current: 67.0/38.5 A</p> <p data-bbox="196 913 636 947">Starting current: 840 %</p> <p data-bbox="196 947 608 981">Cos phi - power factor: 0.84</p> <p data-bbox="196 981 671 1014">Rated speed: 1485 rpm</p> <p data-bbox="196 1014 681 1048">IE efficiency: IE4 95,4%</p> <p data-bbox="196 1048 604 1081">IE Efficiency class: IE4</p> <p data-bbox="196 1081 643 1115">Motor efficiency at full load: 95.4 %</p> <p data-bbox="196 1115 643 1149">Motor efficiency at 3/4 load: 95.4 %</p> <p data-bbox="196 1149 643 1182">Motor efficiency at 1/2 load: 94.8 %</p> <p data-bbox="196 1182 584 1216">Number of poles: 4</p> <p data-bbox="196 1216 617 1249">Enclosure class (IEC 34-5): IP55</p> <p data-bbox="196 1249 584 1283">Insulation class (IEC 85): F</p> <p data-bbox="196 1283 671 1317">Motor No: 92691591</p> <p data-bbox="196 1317 879 1350">Bearing insulation type N-end: CERAMIC SHAFT COATING</p> <p data-bbox="196 1361 284 1395">Others:</p> <p data-bbox="196 1395 636 1429">Minimum efficiency index, MEI ≥: 0.67</p> <p data-bbox="196 1429 643 1462">Net weight: 768 kg</p> <p data-bbox="196 1462 643 1496">Gross weight: 854 kg</p> <p data-bbox="196 1496 649 1529">Shipping volume: 1.88 m³</p> <p data-bbox="196 1529 604 1563">Country of origin: HU</p> <p data-bbox="196 1563 671 1597">Custom tariff no.: 84137051</p> <p data-bbox="196 1597 604 1630">Language on pump nameplate: GB</p>

On request NBGE 200-150-315.2/294 AIASF2LVSBQQVSW3 50 Hz

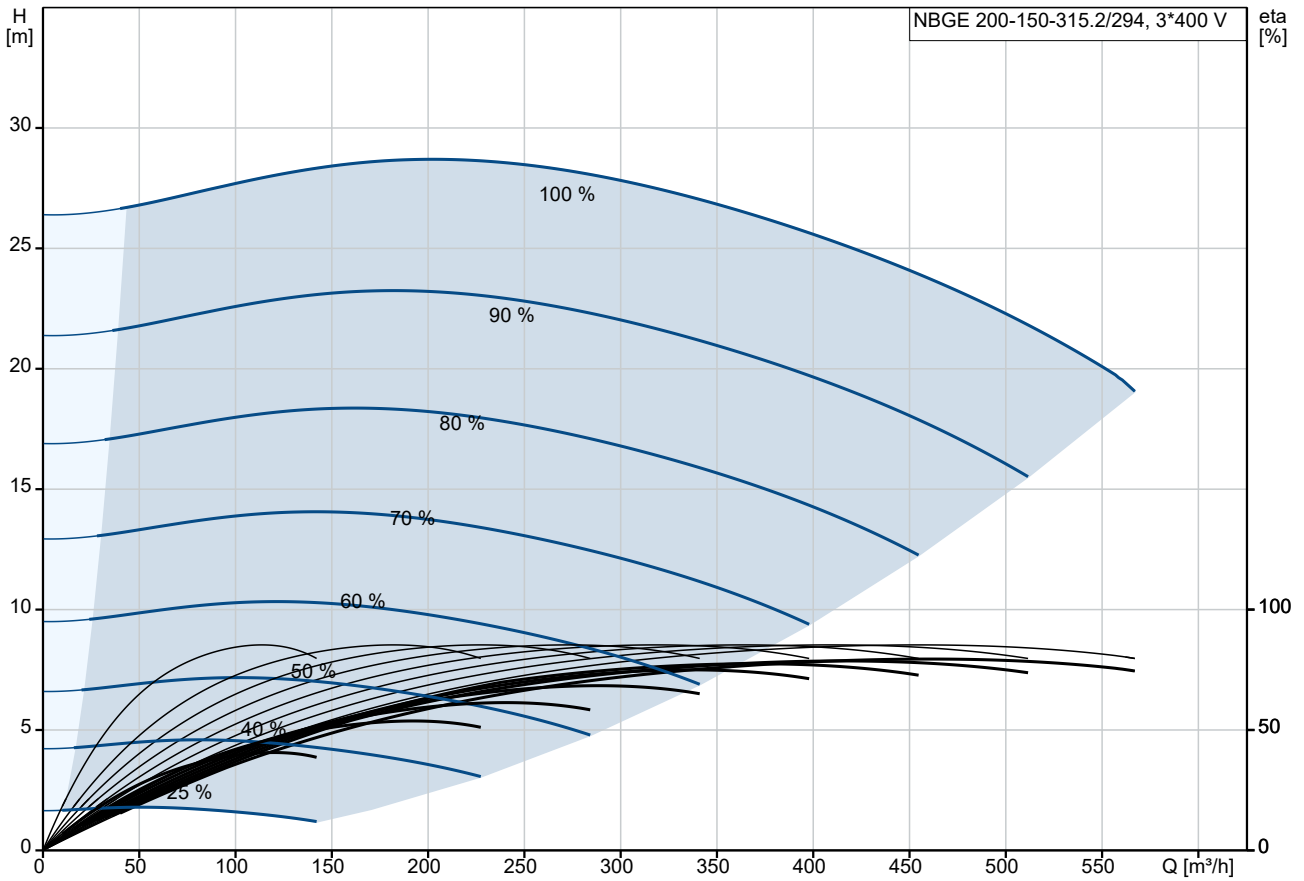

Pumped liquid = Water
 Liquid temperature during operation = 20 °C
 Density = 998.2 kg/m³

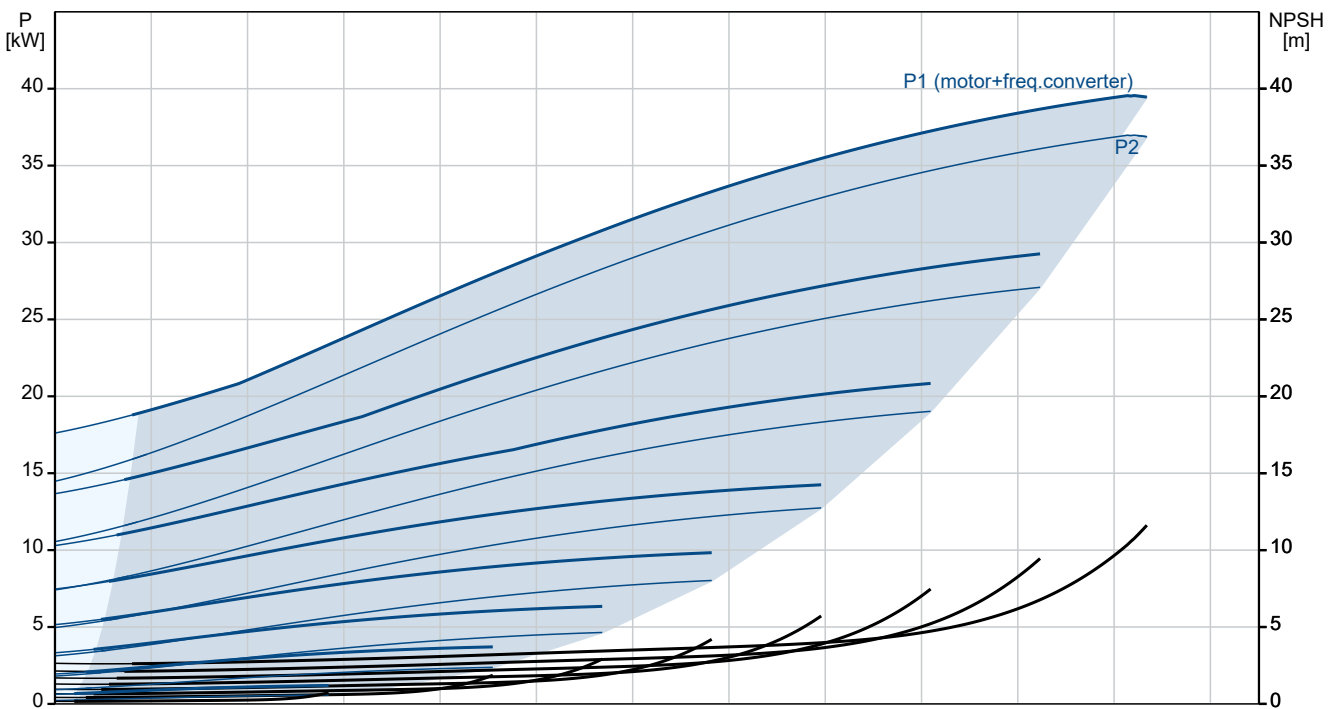

Description	Value
General information:	
Product name:	NBGE 200-150-315.2/294 AIASF2LVSBQQVSW3
Product No:	On request
EAN number:	On request
Technical:	
Pump speed on which pump data are based:	1485 rpm
Rated flow:	438.4 m³/h
Rated head:	24.44 m
Actual impeller diameter:	294 mm
Nominal impeller diameter:	315.2
Type of impeller:	Standard
Shaft seal arrangement:	Single
Shaft diameter:	48 mm
Code for shaft seal:	BQQV
Curve tolerance:	ISO9906:2012 3B
Pump version:	AS
Bearing design:	Standard
Materials:	
Pump housing:	Stainless steel
Pump housing:	EN 1.4517
Pump housing:	ASTM CD4MCuN
Wear ring:	Stainless steel
Flange:	Cast iron
Flange:	EN-GJS-500-7
Flange:	ASTM 70-50-05
Impeller:	Stainless steel
Impeller:	EN 1.4517
Impeller:	ASTM CD4MCuN
Internal pump house coating:	No coating
Material code:	L
Code for rubber:	V
Shaft:	Stainless steel
Shaft:	EN 1.4462
Shaft:	SAF 2205
Installation:	
Range of ambient temperature:	-10 .. 50 °C
Maximum operating pressure:	16 bar
Pipe connection standard:	EN 1092-1
Size of inlet connection:	DN 200
Size of outlet connection:	DN 150
Pressure rating for connection:	PN 16
Bearing lubrication:	Grease
Pump housing with feet:	Yes
Support block (Yes/No):	Y
Connect code:	F2
Liquid:	
Pumped liquid:	Water
Liquid temperature range:	-10 .. 90 °C
Selected liquid temperature:	20 °C
Density:	998.2 kg/m³
Electrical data:	
Rated power - P2:	37 kW
Mains frequency:	50 Hz
Rated voltage:	3 x 380-420D/660-725Y V
Rated current:	67.0/38.5 A
Starting current:	840 %

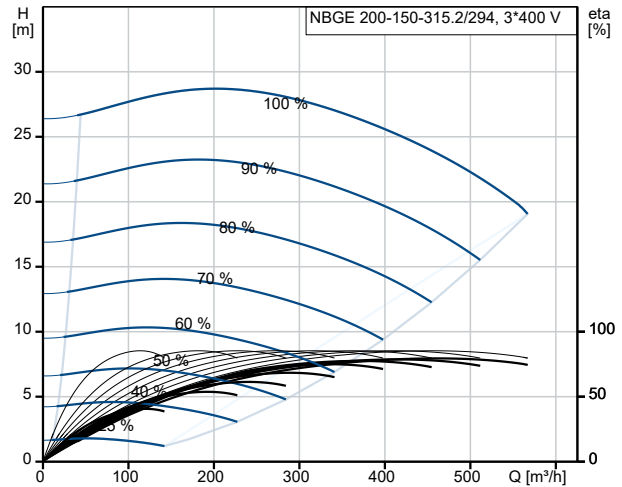

Pumped liquid = Water
Liquid temperature during operation = 20 °C
Density = 998.2 kg/m³

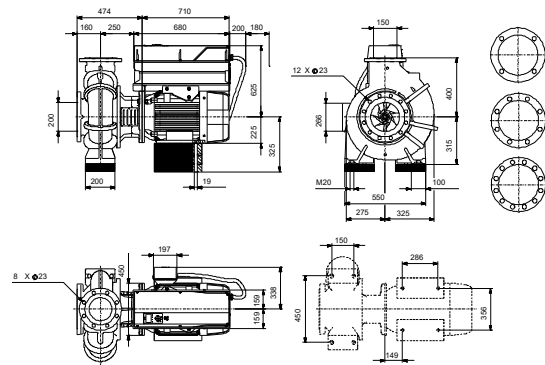
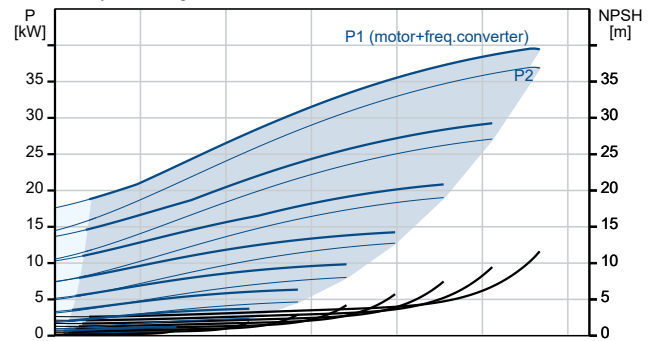



Company name:

Created by:

Phone:

Date:

24/10/2024

Description	Value
Cos phi - power factor:	0.84
Rated speed:	1485 rpm
IE efficiency:	IE4 95,4%
IE Efficiency class:	IE4
Motor efficiency at full load:	95.4 %
Motor efficiency at 3/4 load:	95.4 %
Motor efficiency at 1/2 load:	94.8 %
Number of poles:	4
Enclosure class (IEC 34-5):	IP55
Insulation class (IEC 85):	F
Built-in motor protection:	PTC
Motor No:	92691591
Mount. design. acc. IEC 34-7:	IM B35
Bearing insulation type N-end:	CERAMIC SHAFT COATING
Controls:	
VFD product number:	99616824
Frequency converter:	Built-in
Type of frequency converter:	CUE 3X380-500V IP55 RUG 37KW
Appr. for VFD:	CE, CULUS, C-TICK
Pressure sensor:	N
Others:	
Minimum efficiency index, MEI ≥:	0.67
Net weight:	768 kg
Gross weight:	854 kg
Shipping volume:	1.88 m ³
Country of origin:	HU
Custom tariff no.:	84137051
Language on pump nameplate:	GB

On request NBGE 200-150-315.2/294 AIASF2LVSBQQVSW3 50 Hz

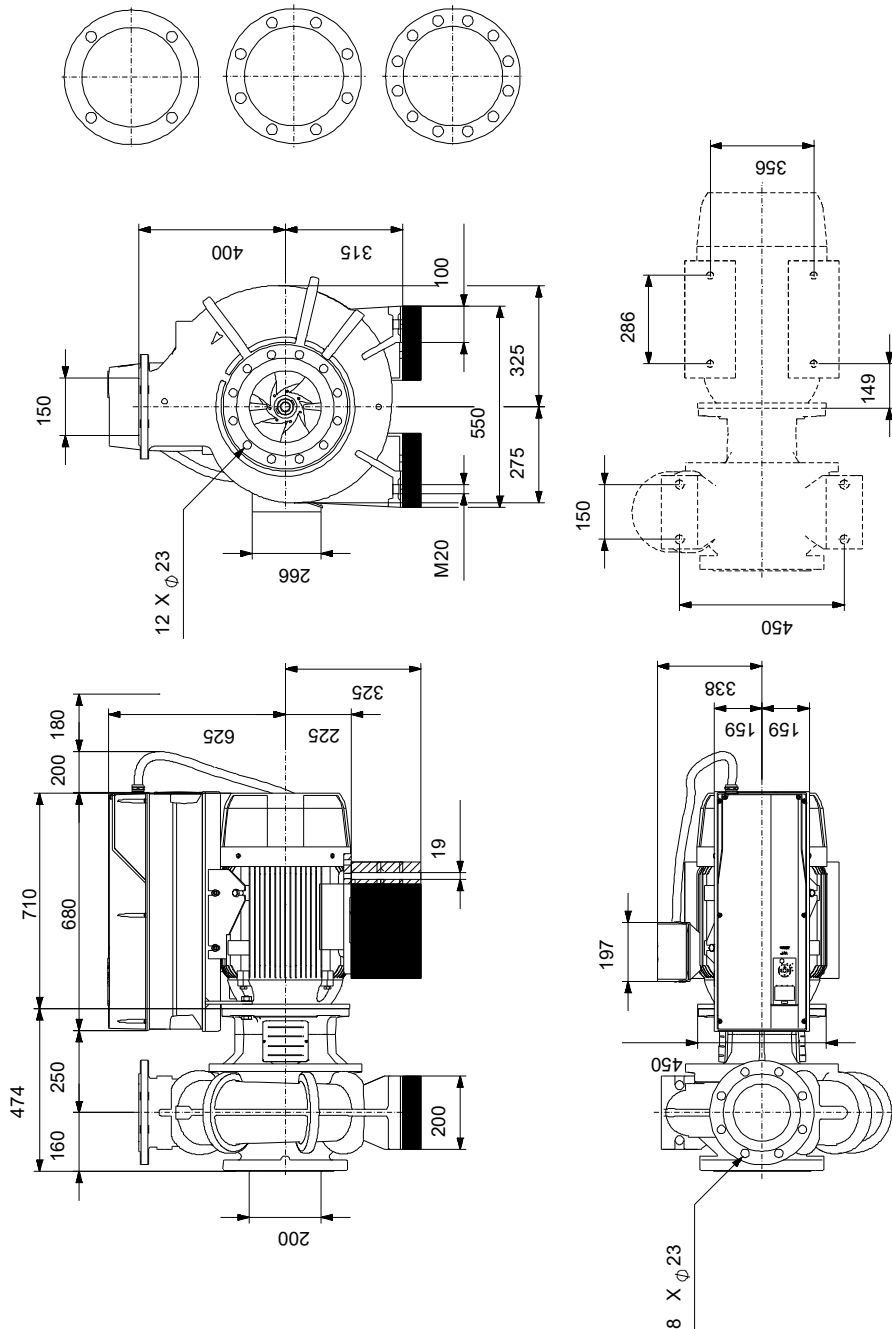

Note! All units are in [mm] unless others are stated.
Disclaimer: This simplified dimensional drawing does not show all details.

On request NBGE 200-150-315.2/294 AIASF2LVSBQQVSW3 50 Hz

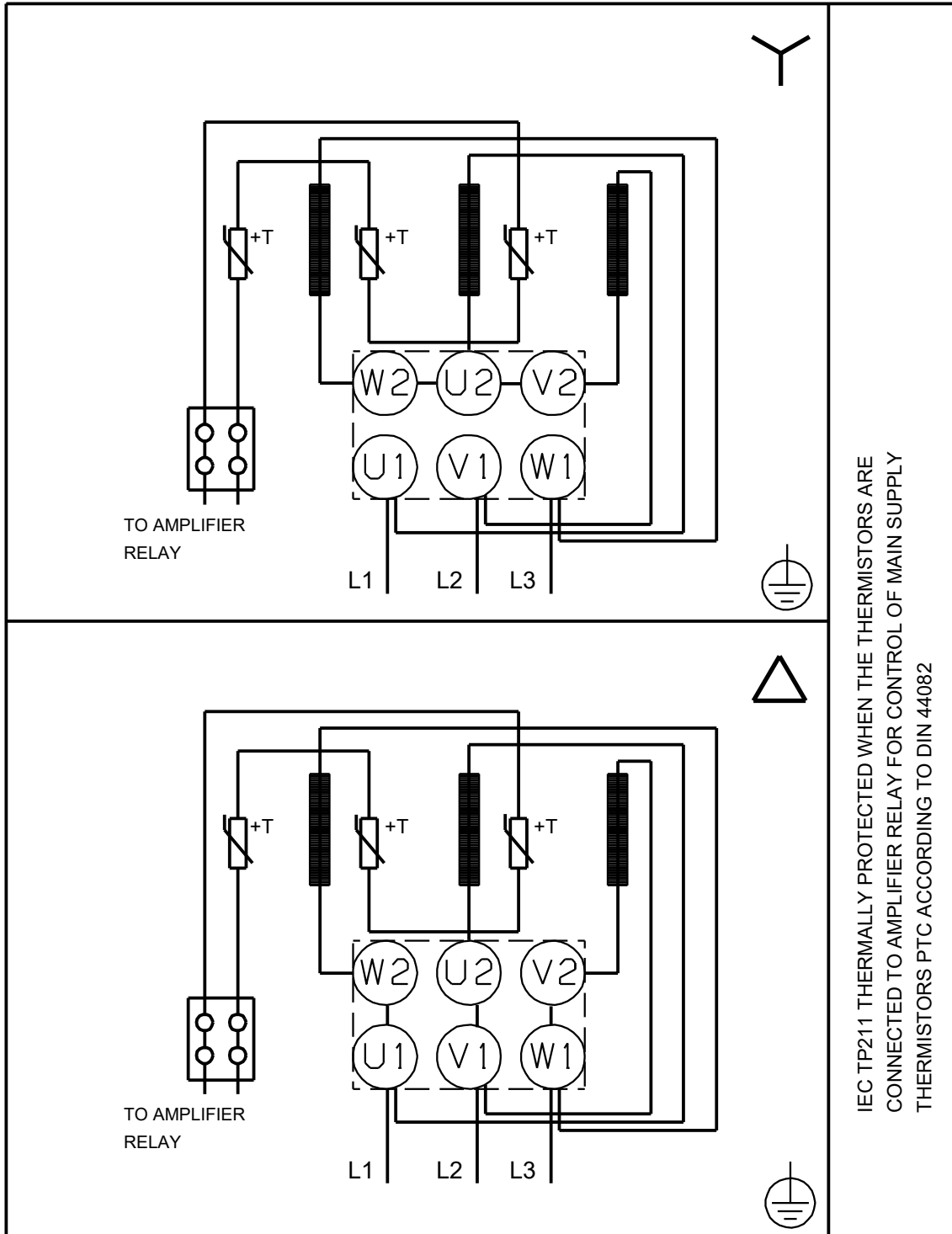

IEC TP211 THERMALLY PROTECTED WHEN THE THERMISTORS ARE
CONNECTED TO AMPLIFIER RELAY FOR CONTROL OF MAIN SUPPLY
THERMISTORS PTC ACCORDING TO DIN 44082

Note! All units are in [mm] unless others are stated.

