

Submittal Data

PROJECT:	UNIT TAG:	QUANTITY:
REPRESENTATIVE: _____	TYPE OF SERVICE:	DATE: _____
ENGINEER:	SUBMITTED BY:	DATE:
CONTRACTOR:	APPROVED BY:	DATE:
	ORDER NO.:	DATE:



TPE 50-830/2 A-F-B-BAQE-PWB

Grundfos TPE Series 1000, TPE2 pumps are single-stage, close-coupled in-line centrifugal pumps with mechanical shaft seal and primely for applications such as heating/cooling/district energy. The pumps are fitted with frequency controlled motors.

Note! Product picture may differ from actual product

Conditions of Service		Pump Data		Motor Data	
Liquid:	Water	Max pressure at stated temp:	16 bar / 120 °C	Rated voltage:	380-480 V
Temperature:	20 °C	Liquid temperature range:	0 .. 120 °C	Mains frequency:	50 Hz
Specific Gravity:	1.000	Maximum ambient temperature:	50 °C	Enclosure class:	IP55
		Shaft seal:	BAQE	Insulation class:	F
		Product number:	On request	Motor protection:	ELEC
				Motor type:	160LB
				Eta 1/1:	92.8 %

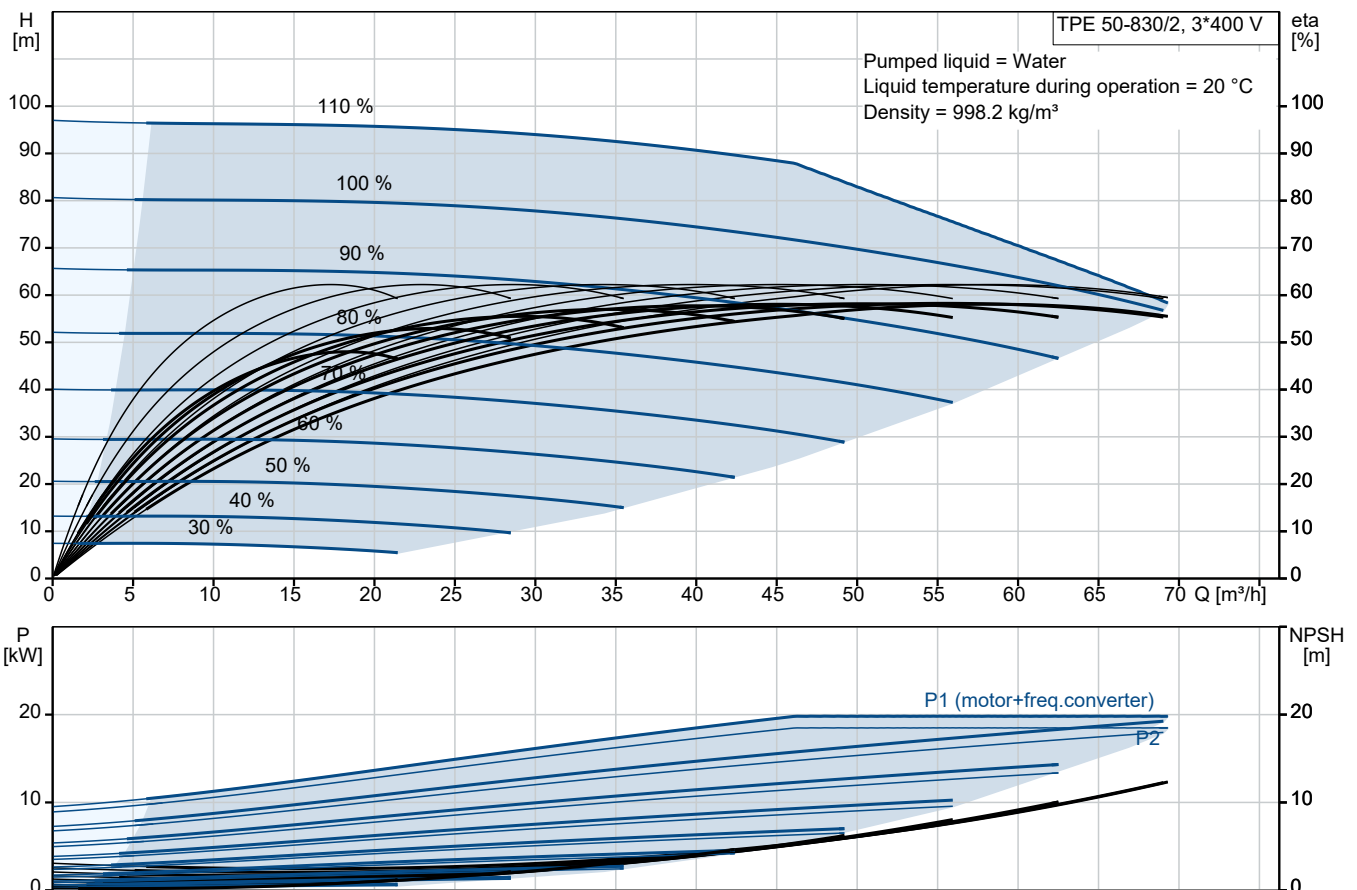

Submittal Data

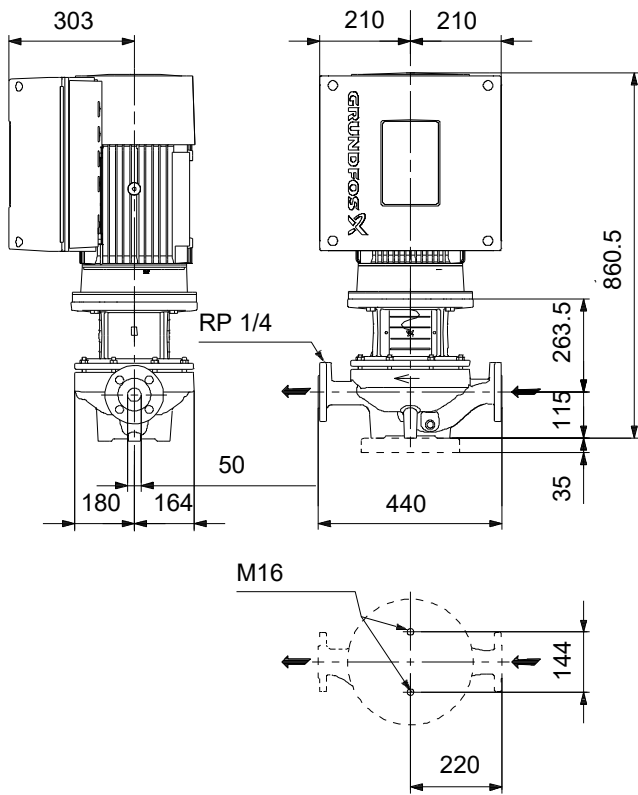

Materials:

Pump housing: Cast iron
Pump housing: ASTM class 35
Impeller: Bronze
Impeller: CuSn10-C
Material code: B

Qty. Description

1 TPE 50-830/2 A-F-B-BAQE-PWB



Note! Product picture may differ from actual product

Product No.: On request

Single-stage, close-coupled, volute pump with in-line suction and discharge ports of identical diameter. The pump is of the top-pull-out design, i.e. the power head (motor, pump head and impeller) can be removed for maintenance or service while the pump housing remains in the pipework.

The pump is fitted with an unbalanced rubber bellows seal. The shaft seal is according to EN 12756. Pipework connection is via PN 16 DIN flanges (EN 1092-2 and ISO 7005-2).

The pump is fitted with a fan-cooled, permanent-magnet synchronous motor. The motor efficiency is classified as IE5 in accordance with IEC 60034-30-2.

The product's minimum efficiency index (MEI) is greater or equal to 0.70. This is by the Commission Regulation (EU) considered as an indicative benchmark for best-performing water pump available on the market as from 1 January 2013.

An operating panel on the motor terminal box enables setting of required setpoint as well as setting of pump to "Min." or "Max." operation or to "Stop". The Grundfos Eye indicator on the operating panel provides visual indication of pump status:

- "Power on": Motor is running (rotating green indicator lights) or not running (permanently green indicator lights)
- "Warning": Motor is still running (rotating yellow indicator lights) or has stopped (permanently yellow indicator lights)
- "Alarm": Motor has stopped (flashing red indicator lights).

Communication with the pump is possible by means of Grundfos GO Remote (accessory). The remote control enables further settings as well as reading out of a number of parameters such as "Actual value", "Speed", "Power input" and total "Power consumption".

Pump

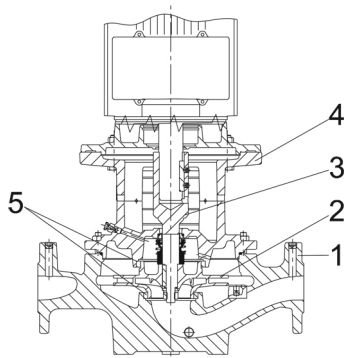

- 1: Pump housing
- 2: Impeller
- 3: Stub shaft
- 4: Pump head/motor stool
- 5: Wear rings

The pump housing is provided with a replaceable brass neck ring to reduce the amount of liquid running from the outlet side of the impeller to the inlet side.

The impeller is secured to the shaft with a nut.

Qty.	Description
1	<p>The pump is fitted with an unbalanced rubber bellows seal with torque transmission across the spring and around the bellows. Due to the bellows, the seal does not wear the shaft, and the axial movement is not prevented by deposits on the shaft.</p> <p>Seal faces:</p> <ul style="list-style-type: none"> • Rotating seal ring material: carbon graphite, metal-impregnated • Stationary seat material: silicon carbide (SiC) <p>Due to the favourable lubricating properties of carbon graphite, the seal is suitable for use even under poor lubricating conditions, such as hot water.</p> <p>However, under such conditions, wear on the carbon graphite face can be expected, and seal life will be reduced .</p> <p>The material pairing is not recommended for liquids containing particles as this will result in wear on the SiC face. Secondary seal material: EPDM (ethylene-propylene rubber) EPDM has excellent resistance to hot water. EPDM is not suitable for mineral oils.</p> <p>A circulation of liquid through the duct of the air vent screw ensures lubrication and cooling of the shaft seal. The flanges have tappings for mounting of pressure gauges.</p> <p>The motor stool forms connection between the pump housing and the motor, and is equipped with a manual air vent screw for venting of the pump housing and the shaft seal chamber. The sealing between motor stool and pump housing is an O-ring.</p> <p>The central part of the motor stool is provided with guards for protection against the shaft and coupling. The pump shaft is fastened directly on the motor shaft with key and set screws.</p> <p>The pump is mounted with a base plate.</p> <p>Motor</p> <p>The motor is a totally enclosed, fan-cooled motor with principal dimensions to IEC and DIN standards. Electrical tolerances comply with IEC 60034.</p> <p>The motor efficiency is classified as IE5 in accordance with IEC 60034-30-2.</p> <p>The motor requires no external motor protection. The motor control unit incorporates protection against slow- and quick-rising temperatures, e.g. constant overload and stalled conditions.</p> <p>Further product details</p> <p>Technical data</p> <p>Controls:</p> <p>Frequency converter: Built-in</p> <p>Liquid:</p> <p>Pumped liquid: Water</p> <p>Liquid temperature range: 0 .. 120 °C</p> <p>Selected liquid temperature: 20 °C</p> <p>Density: 998.2 kg/m³</p> <p>Technical:</p> <p>Pump speed on which pump data are based: 2945 rpm</p> <p>Rated flow: 56.7 m³/h</p> <p>Rated head: 68 m</p> <p>Actual impeller diameter: 245 mm</p> <p>Code for shaft seal: BAQE</p> <p>Curve tolerance: ISO9906:2012 3B</p> <p>Materials:</p> <p>Pump housing: Cast iron EN-GJL-250 ASTM class 35</p> <p>Impeller: Bronze CuSn10-C</p>

Qty.	Description
1	<p>Installation:</p> <p>Range of ambient temperature: -20 .. 50 °C</p> <p>Maximum operating pressure: 16 bar</p> <p>Max pressure at stated temp: 16 bar / 120 °C</p> <p>Type of connection: DIN</p> <p>Size of connection: DN 50</p> <p>Pressure rating for connection: PN 16</p> <p>Port-to-port length: 440 mm</p> <p>Flange size for motor: FF300</p> <p>Electrical data:</p> <p>Motor type: 160LB</p> <p>Rated power - P2: 18.5 kW</p> <p>Mains frequency: 50 Hz</p> <p>Rated voltage: 3 x 380-480 V</p> <p>Rated current: 33.0-27.8 A</p> <p>Cos phi - power factor: 0.94-0.92</p> <p>Rated speed: 360-4000 rpm</p> <p>IE Efficiency class: IE5</p> <p>Motor efficiency at full load: 92.8 %</p> <p>Number of poles: 2</p> <p>Enclosure class (IEC 34-5): IP55</p> <p>Insulation class (IEC 85): F</p> <p>Motor No: 92875517</p> <p>Others:</p> <p>Minimum efficiency index, MEI ≥: 0.70</p> <p>Net weight: 154 kg</p> <p>Gross weight: 191 kg</p> <p>Shipping volume: 0.56 m³</p> <p>Country of origin: HU</p> <p>Custom tariff no.: 84137051</p>

On request TPE 50-830/2 A-F-B-BAQE-PWB 50 Hz

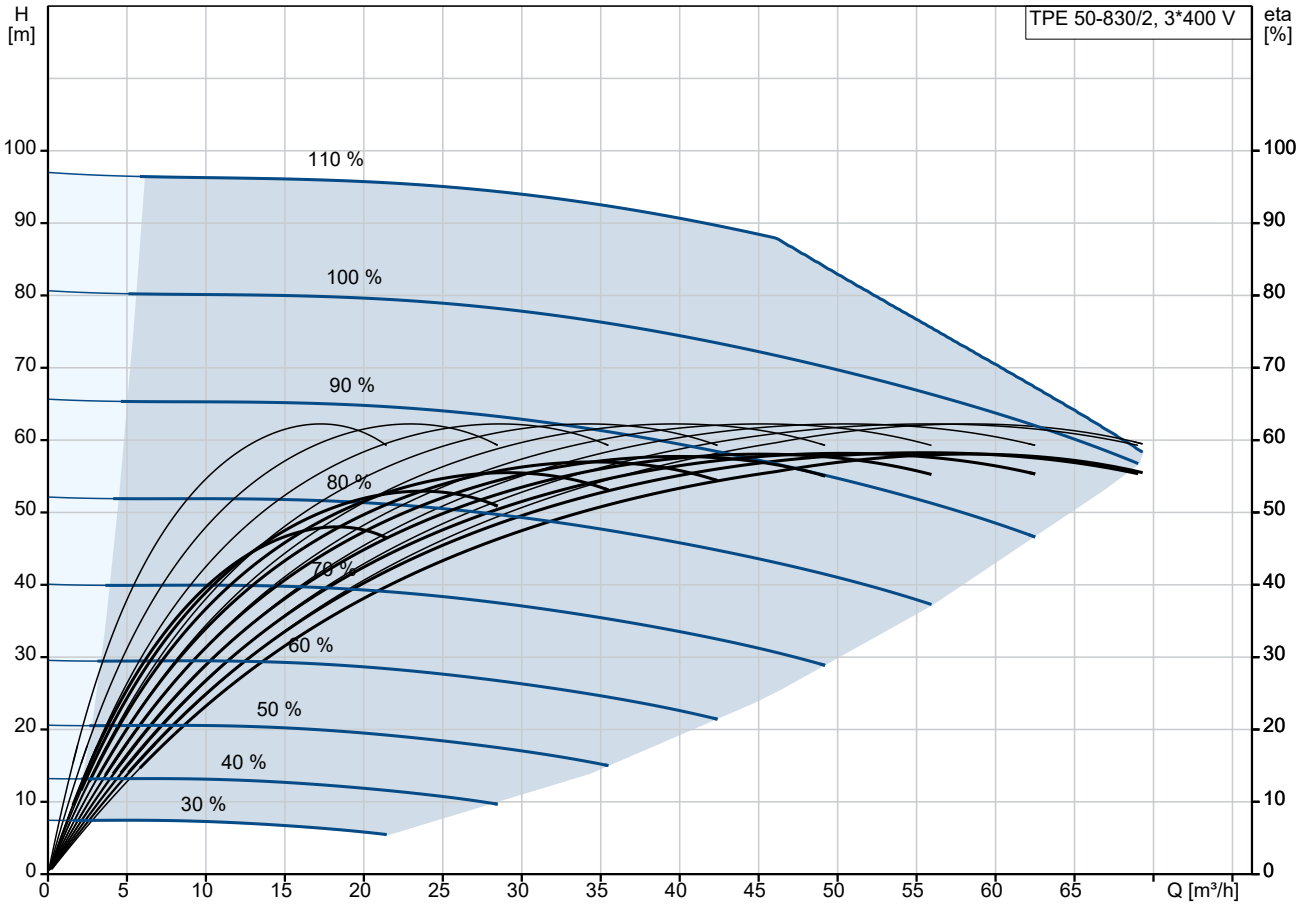

Pumped liquid = Water
 Liquid temperature during operation = 20 °C
 Density = 998.2 kg/m³

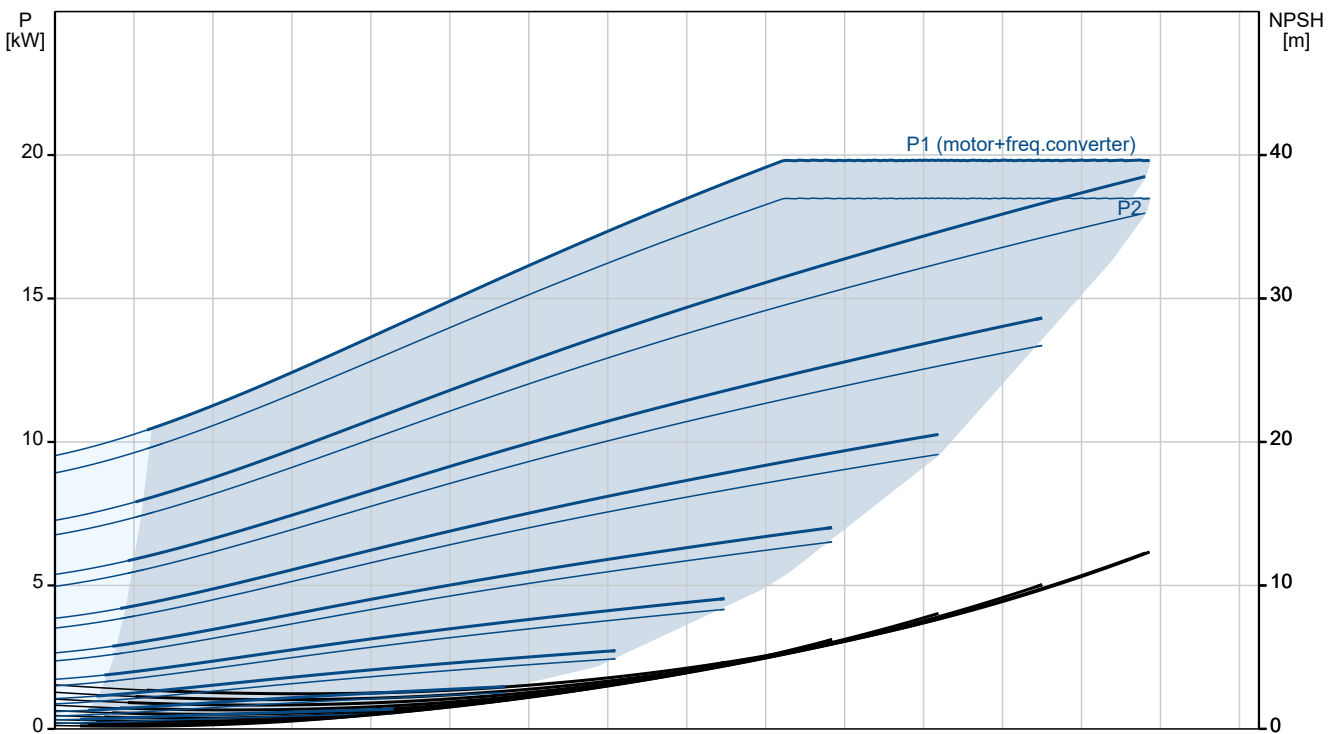

Description	Value
General information:	
Product name:	TPE 50-830/2 A-F-B-BAQE-PWB
Product No:	On request
EAN number:	On request
Technical:	
Pump speed on which pump data are based:	2945 rpm
Rated flow:	56.7 m ³ /h
Rated head:	68 m
Maximum head:	830 dm
Actual impeller diameter:	245 mm
Code for shaft seal:	BAQE
Curve tolerance:	ISO9906:2012 3B
Pump version:	A
Materials:	
Pump housing:	Cast iron
Pump housing:	EN-GJL-250
Pump housing:	ASTM class 35
Impeller:	Bronze
Impeller:	CuSn10-C
Material code:	B
Installation:	
Range of ambient temperature:	-20 .. 50 °C
Maximum operating pressure:	16 bar
Max pressure at stated temp:	16 bar / 120 °C
Type of connection:	DIN
Size of connection:	DN 50
Pressure rating for connection:	PN 16
Port-to-port length:	440 mm
Flange size for motor:	FF300
Connect code:	F
Liquid:	
Pumped liquid:	Water
Liquid temperature range:	0 .. 120 °C
Selected liquid temperature:	20 °C
Density:	998.2 kg/m ³
Electrical data:	
Motor type:	160LB
Rated power - P2:	18.5 kW
Mains frequency:	50 Hz
Rated voltage:	3 x 380-480 V
Rated current:	33.0-27.8 A
Cos phi - power factor:	0.94-0.92
Rated speed:	360-4000 rpm
IE Efficiency class:	IE5
Motor efficiency at full load:	92.8 %
Number of poles:	2
Enclosure class (IEC 34-5):	IP55
Insulation class (IEC 85):	F
Built-in motor protection:	ELEC
Motor No:	92875517
Controls:	
Control panel:	HMI200 - Standard
Function Module:	FM310 - Advanced
Frequency converter:	Built-in
Others:	
Minimum efficiency index, MEI ≥:	0.70

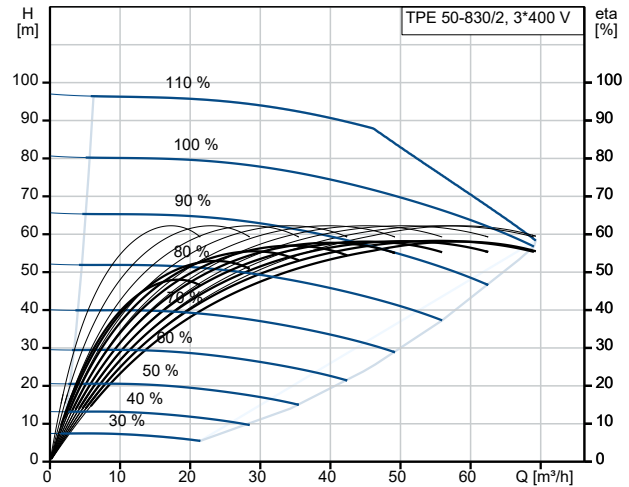

Pumped liquid = Water
Liquid temperature during operation = 20 °C
Density = 998.2 kg/m³

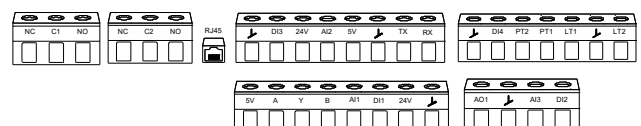
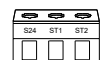
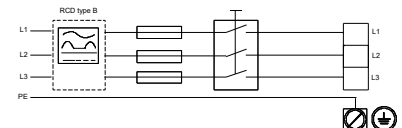
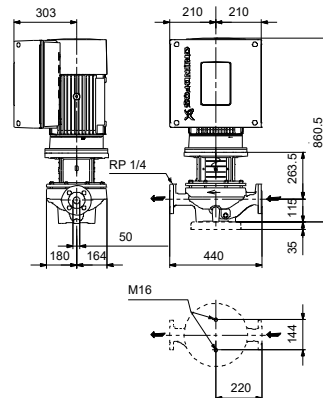
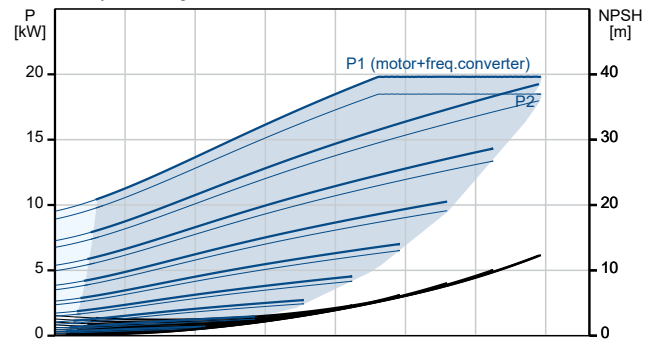



Company name:

Created by:

Phone:

Date:

21/10/2024

Description	Value
Net weight:	154 kg
Gross weight:	191 kg
Shipping volume:	0.56 m ³
Config. file no:	92936515
Country of origin:	HU
Custom tariff no.:	84137051

On request TPE 50-830/2 A-F-B-BAQE-PWB 50 Hz

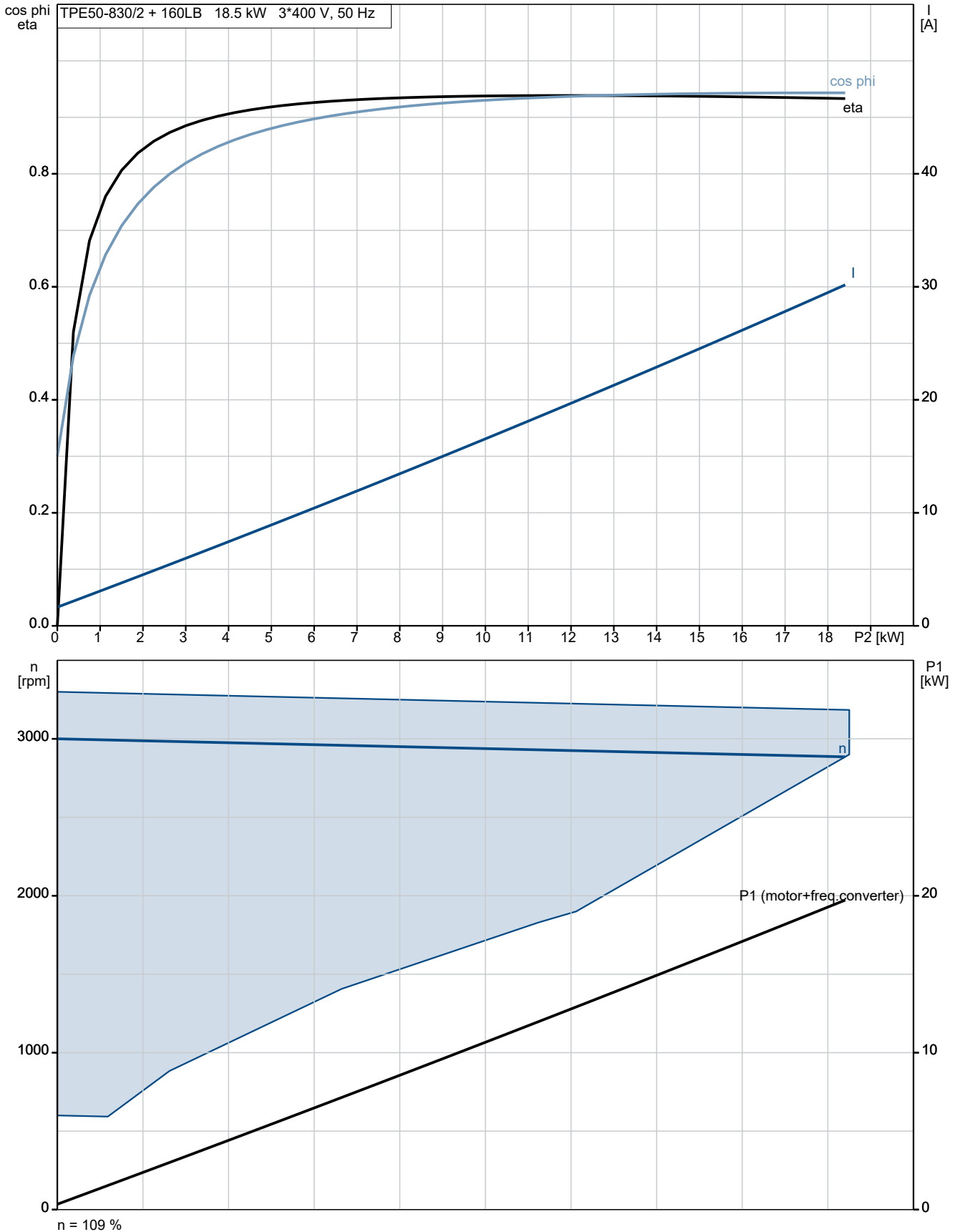

On request TPE 50-830/2 A-F-B-BAQE-PWB 50 Hz

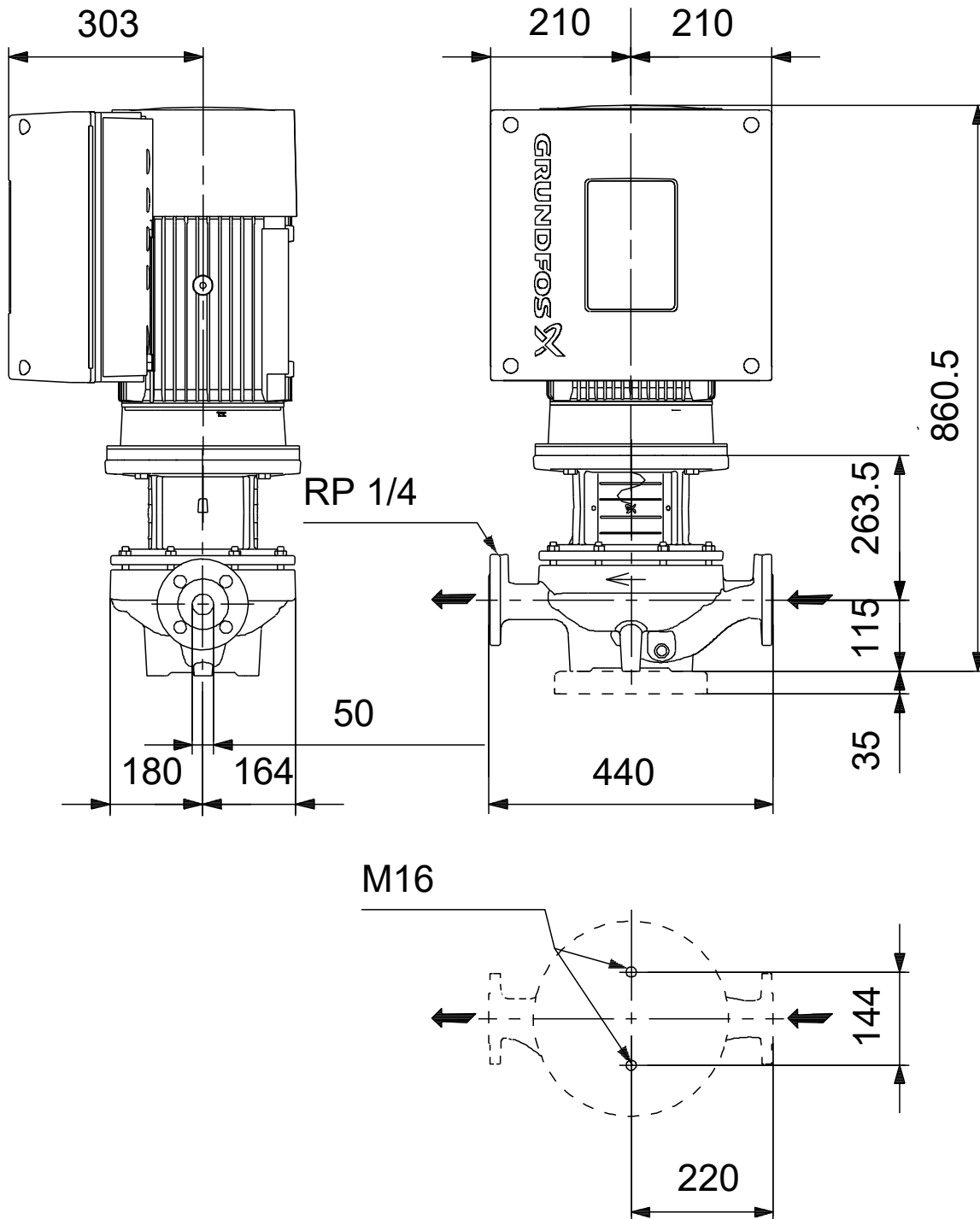

Note! All units are in [mm] unless others are stated.
 Disclaimer: This simplified dimensional drawing does not show all details.

On request TPE 50-830/2 A-F-B-BAQE-PWB 50 Hz

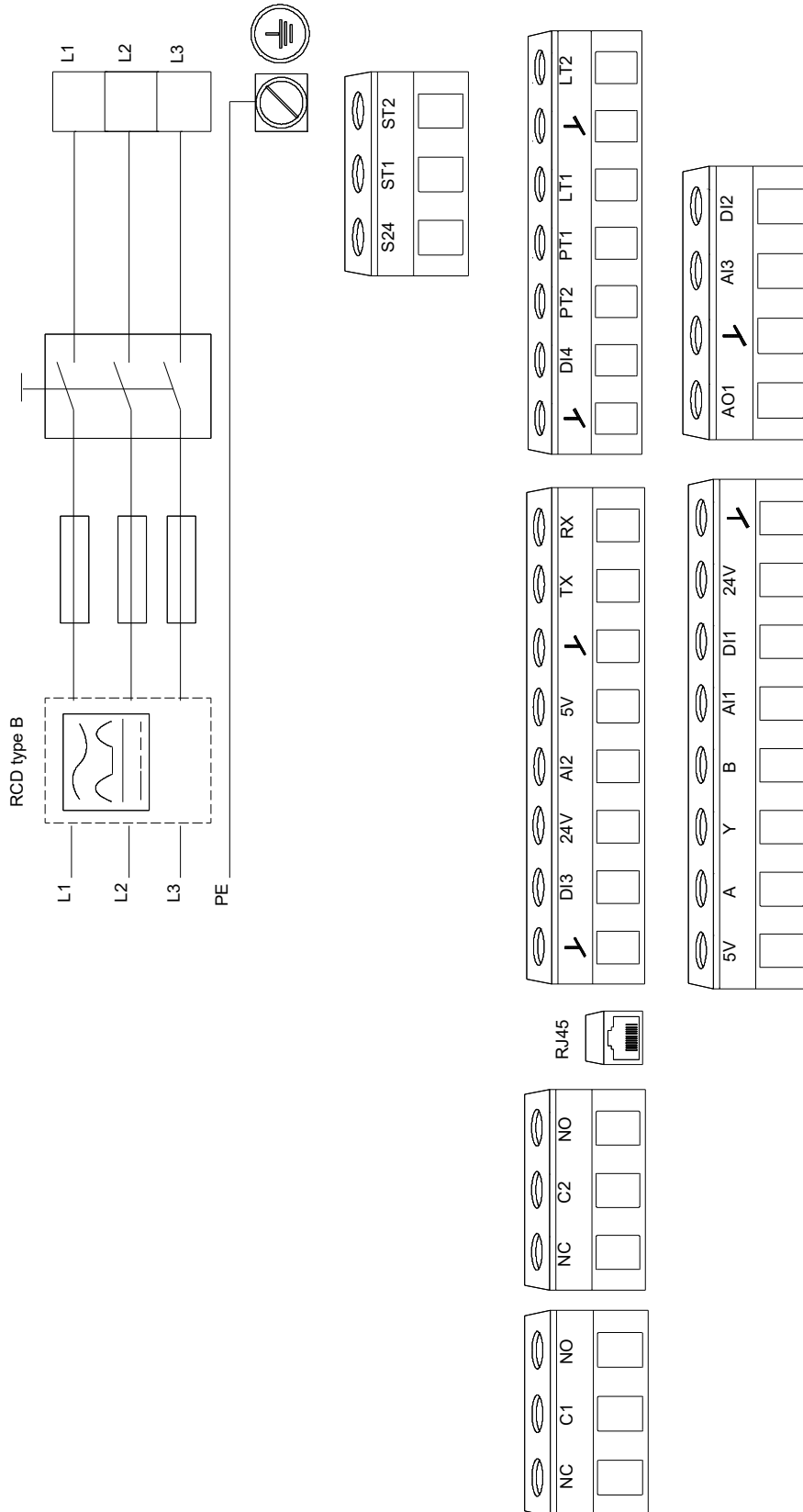

Note! All units are in [mm] unless others are stated.

