

Submittal Data

PROJECT:	UNIT TAG:	QUANTITY:
REPRESENTATIVE: _____	TYPE OF SERVICE:	DATE: _____
ENGINEER:	SUBMITTED BY:	DATE:
CONTRACTOR:	APPROVED BY:	DATE:
	ORDER NO.:	DATE:



TPED 50-830/2 S-A-F-A-BAQE-PWB

Grundfos TPED Series 2000, TPE3 D pumps are single-stage, close-coupled in-line centrifugal twin-head pumps with mechanical shaft seal and primely for applications such as heating/cooling/ district energy. The pumps are fitted with frequency controlled motors and differential pressure transmitter.

Note! Product picture may differ from actual product

Conditions of Service		Pump Data		Motor Data	
Liquid:	Water	Max pressure at stated temp:	16 bar / 120 °C	Rated voltage:	380-480 V
Temperature:	20 °C	Liquid temperature range:	0 .. 120 °C	Mains frequency:	50 / 60 Hz
Specific Gravity:	1.000	Maximum ambient temperature:	50 °C	Enclosure class:	IP55
		Shaft seal:	BAQE	Insulation class:	F
		Product number:	On request	Motor protection:	ELEC
				Motor type:	160LB
				Eta 1/1:	92.8 %

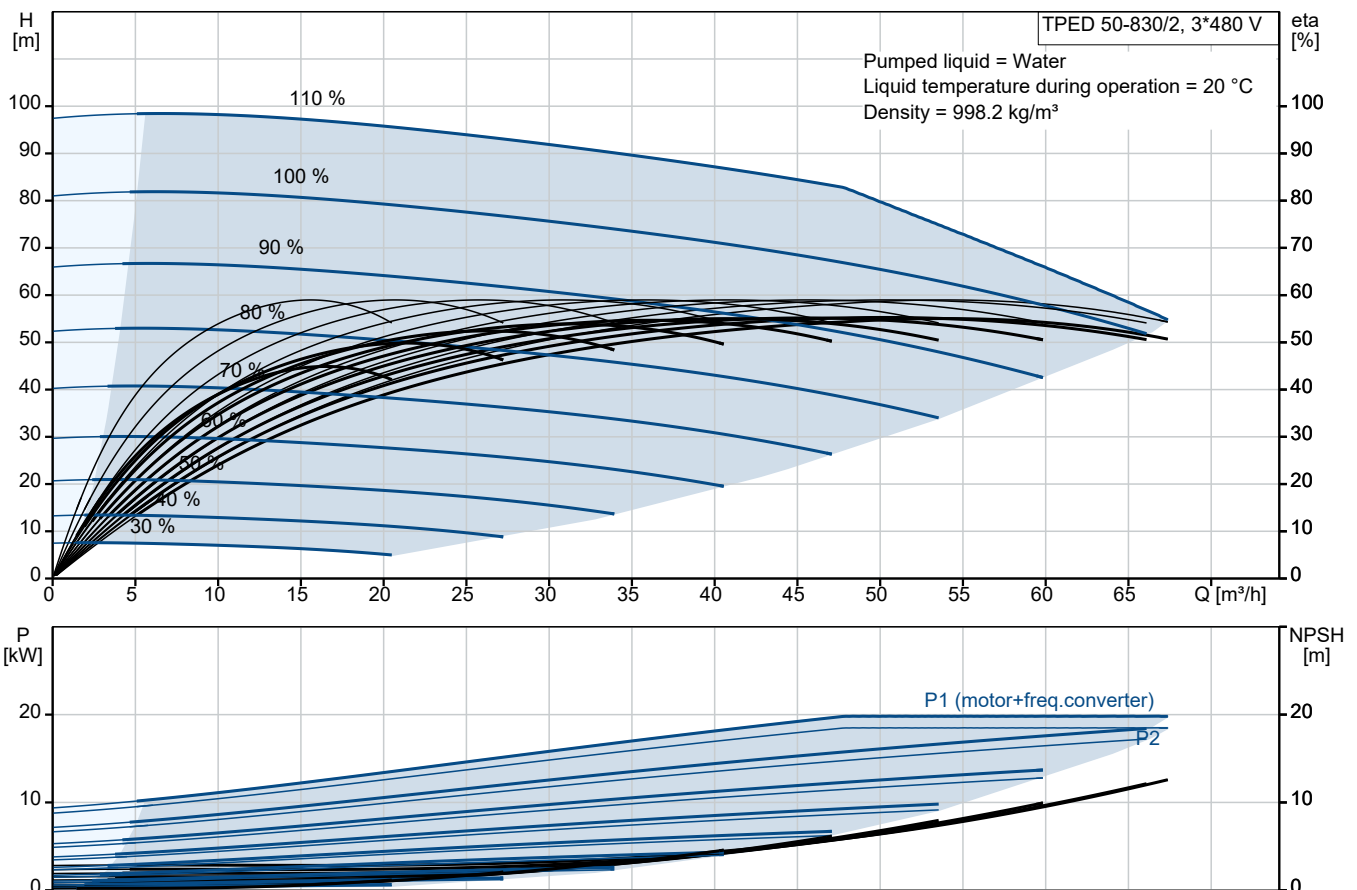

Submittal Data

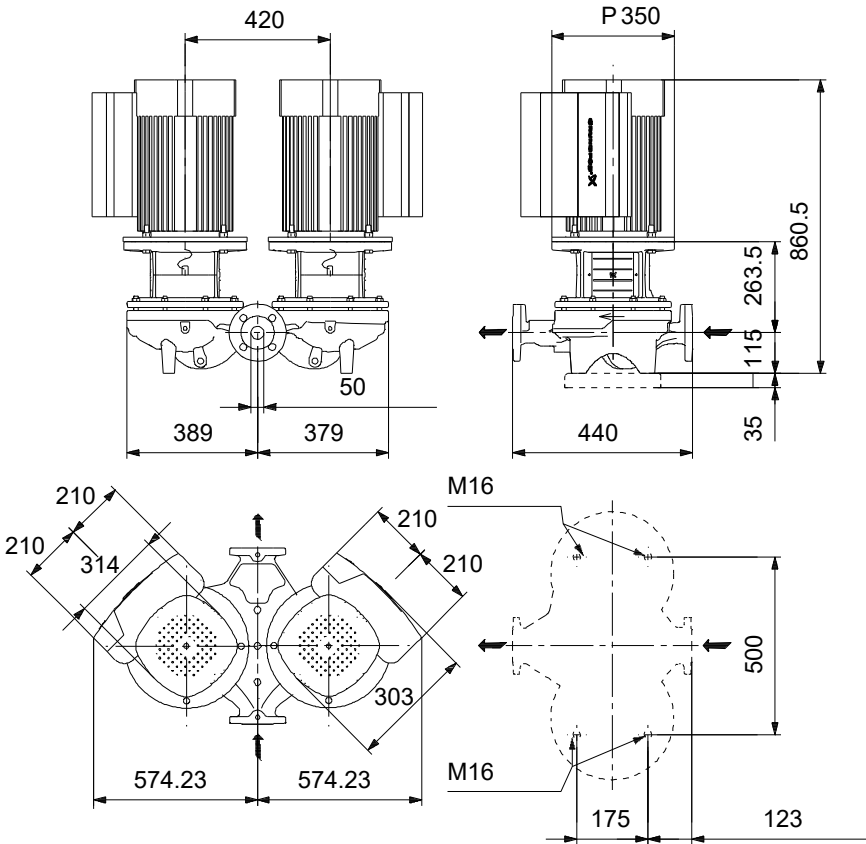

- Materials:**
- Pump housing: Cast iron
 - Pump housing: ASTM class 35
 - Impeller: Cast iron
 - Impeller: ASTM class 30
 - Impeller: EN-GJL-200
 - Material code: A

Qty. Description

1 **TPED 50-830/2 S-A-F-A-BAQE-PWB**



Note! Product picture may differ from actual product

Product No.: On request

Single-stage, close-coupled, volute twin-head pump with in-line suction and discharge ports of identical diameter. The twin-head pump is designed with two parallel power-heads. The pump is of the top-pull-out design, i.e. the power head (motor, pump head and impeller) can be removed for maintenance or service while the pump housing remains in the pipework.

Each power head is fitted with an unbalanced rubber bellows seal. The shaft seal is according to EN 12756. Pipework connection is via PN 16 DIN flanges (EN 1092-2 and ISO 7005-2).

Each power head is fitted with a fan-cooled, permanent-magnet synchronous motor of identical size. The motor efficiency is classified as IE5 in accordance with IEC 60034-30-2.

The motor includes a frequency converter and PI controller in the motor terminal box. This enables continuously variable control of the motor speed, which again enables adaptation of the performance to a given requirement. The pump is fitted with a differential pressure sensor. The pump is suitable for applications requiring pressure control. The pump is fitted with a differential-pressure transmitter registering the differential pressure across the pump and enabling constant pressure or proportional-pressure control of the pump.

A cable ensures communication between the two power heads. The selector switch in the terminal boxes enables changeover between the operating modes "alternating operation" and "standby operation".

The product's minimum efficiency index (MEI) is greater or equal to 0.70. This is by the Commission Regulation (EU) considered as an indicative benchmark for best-performing water pump available on the market as from 1 January 2013.

A control panel enables setting of required setpoint as well as setting of pump to "Min." or "Max." operation or to "Stop".

The control panel has indicator lights for "Operation" and "Fault".

Communication with the pump is possible by means of the Grundfos GO Remote (accessory).

The remote control enables further settings as well as reading out of a number of parameters such as "Actual value", "Speed", "Power input" and total "Power consumption".

Pump

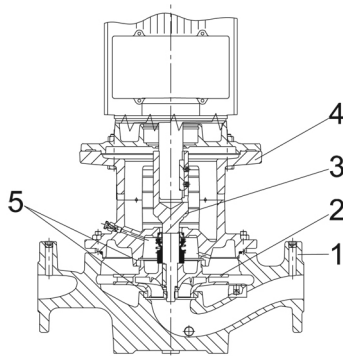

- 1: Pump housing
- 2: Impeller
- 3: Stub shaft
- 4: Pump head/motor stool
- 5: Wear rings

Qty. Description

1 The twin-head pump is designed with two parallel power-heads. A non-return flap valve in the common discharge port is opened by the flow of the pumped liquid and prevents backflow of liquid into the idle pump head.

The pump housing is provided with a replaceable brass neck ring to reduce the amount of liquid running from the outlet side of the impeller to the inlet side.

The impeller is secured to the shaft with a nut.

The pump is fitted with an unbalanced rubber bellows seal with torque transmission across the spring and around the bellows. Due to the bellows, the seal does not wear the shaft, and the axial movement is not prevented by deposits on the shaft.

Seal faces:

- Rotating seal ring material: carbon graphite, metal-impregnated
- Stationary seat material: silicon carbide (SiC)

Due to the favourable lubricating properties of carbon graphite, the seal is suitable for use even under poor lubricating conditions, such as hot water.

However, under such conditions, wear on the carbon graphite face can be expected, and seal life will be reduced .

The material pairing is not recommended for liquids containing particles as this will result in wear on the SiC face.

Secondary seal material: EPDM (ethylene-propylene rubber)

EPDM has excellent resistance to hot water. EPDM is not suitable for mineral oils.

A circulation of liquid through the duct of the air vent screw ensures lubrication and cooling of the shaft seal.

The pump housing has four Rp 1/8 tappings for mounting of automatic air vents. Fit an air vent to the upper pump housing if the twin-head pump is to be installed in a horizontal pipeline with horizontal pump shaft.

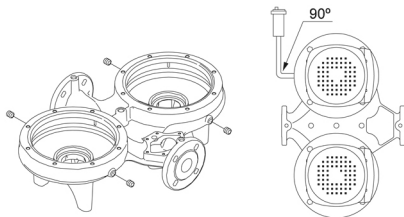

The flanges have tappings for mounting of pressure gauges.

The motor stool forms connection between the pump housing and the motor, and is equipped with a manual air vent screw for venting of the pump housing and the shaft seal chamber. The sealing between motor stool and pump housing is an O-ring.

The central part of the motor stool is provided with guards for protection against the shaft and coupling. The pump shaft is fastened directly on the motor shaft with key and set screws.

The pump is mounted with a base plate.

Motor

The motor is a totally enclosed, fan-cooled motor with principal dimensions to IEC and DIN standards. Electrical tolerances comply with IEC 60034.

The motor is flange-mounted with free-hole flange (FF).

Motor-mounting designation in accordance with IEC 60034-7: IM B 5, IM V 1 (Code I) / IM 3001, IM 3011 (Code II).

The motor efficiency is classified as IE5 in accordance with IEC 60034-30-2.

The motor requires no external motor protection. The motor control unit incorporates protection against slow- and quick-rising temperatures, e.g. constant overload and stalled conditions.

The terminal box holds terminals for these connections:

- one dedicated digital input
- two analog inputs, 0(4)-20 mA, 0-5 V, 0-10 V, 0.5 - 3.5 V; the factory-fitted pressure sensor is connected to one of these inputs
- 5 V voltage supply to potentiometer and sensor
- one configurable digital input or open-collector output
- Grundfos Digital Sensor input and output
- 24 V voltage supply for sensors
- two signal relay outputs (potential-free contacts)
- the two power heads communicate via wireless GENIair or wired GENI connection
- interface for Grundfos CIM fieldbus module.

Further product details

Qty. Description

1 Technical data

Controls:

Frequency converter: Built-in

Liquid:

Pumped liquid: Water

Liquid temperature range: 0 .. 120 °C

Selected liquid temperature: 20 °C

Density: 998.2 kg/m³

Technical:

Pump speed on which pump data are based: 2940 rpm

Rated flow: 51.7 m³/h

Rated head: 66.3 m

Actual impeller diameter: 245 mm

Code for shaft seal: BAQE

Curve tolerance: ISO9906:2012 3B

Materials:

Pump housing: Cast iron
EN-GJL-250
ASTM class 35

Impeller: Cast iron
EN-GJL-200
ASTM class 30

Installation:

Range of ambient temperature: -20 .. 50 °C

Maximum operating pressure: 16 bar

Max pressure at stated temp: 16 bar / 120 °C

Type of connection: DIN

Size of connection: DN 50

Pressure rating for connection: PN 16

Port-to-port length: 440 mm

Flange size for motor: FF300

Electrical data:

Motor type: 160LB

Rated power - P2: 18.5 kW

Mains frequency: 50 / 60 Hz

Rated voltage: 3 x 380-480 V

Rated current: 33.0-27.8 A

Cos phi - power factor: 0.94-0.92

Rated speed: 360-4000 rpm

IE Efficiency class: IE5

Motor efficiency at full load: 92.8 %

Number of poles: 2

Enclosure class (IEC 34-5): IP55

Insulation class (IEC 85): F

Motor No: 92875540

Others:

Minimum efficiency index, MEI ≥: 0.70

Net weight: 304 kg

Gross weight: 367 kg

Shipping volume: 1.87 m³

Country of origin: HU



Company name:

Created by:

Phone:

Date:

22/10/2024

Qty.	Description
1	Custom tariff no.: 84137065

On request TPED 50-830/2 S-A-F-A-BAQE-PWB

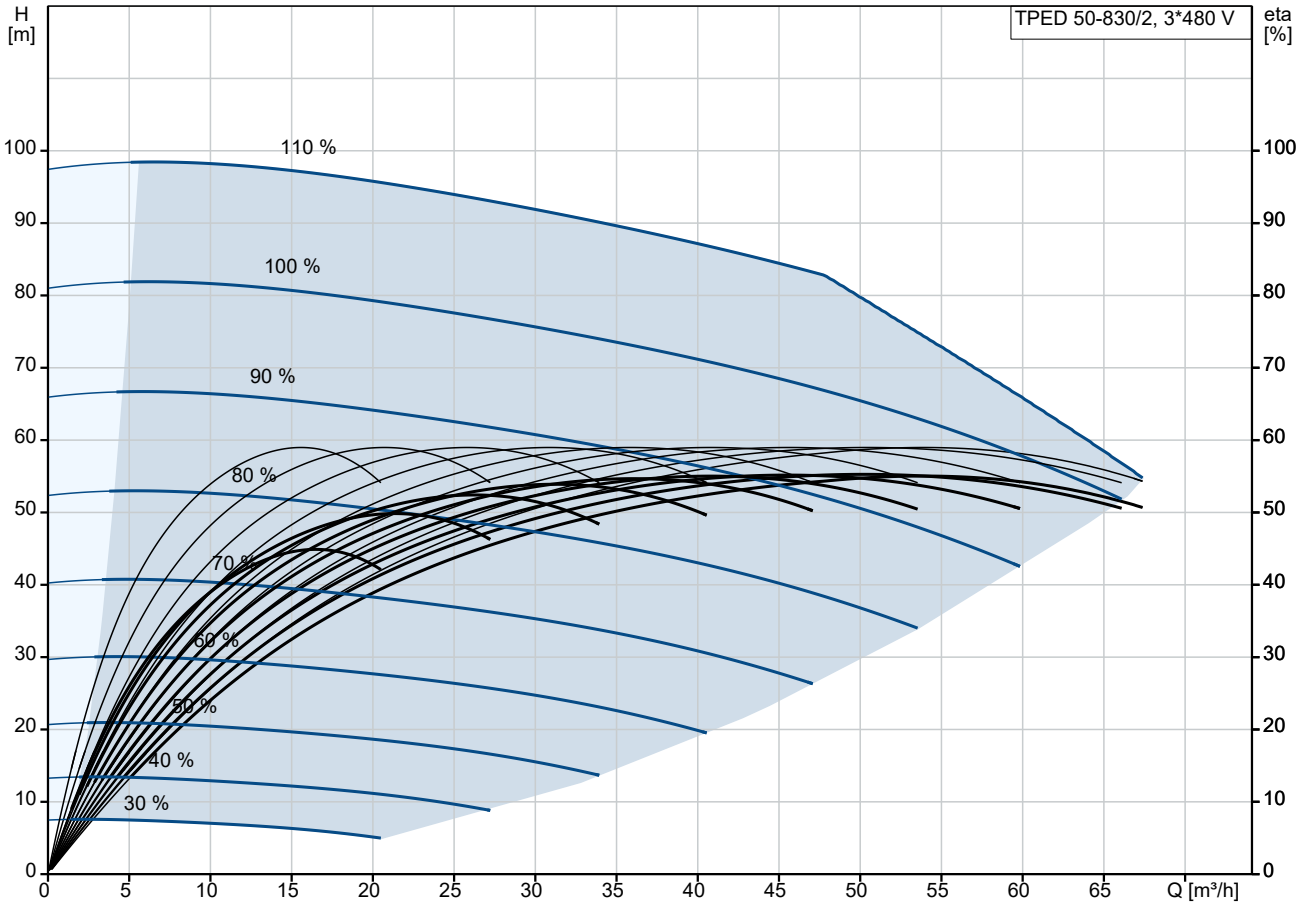

Pumped liquid = Water
 Liquid temperature during operation = 20 °C
 Density = 998.2 kg/m³

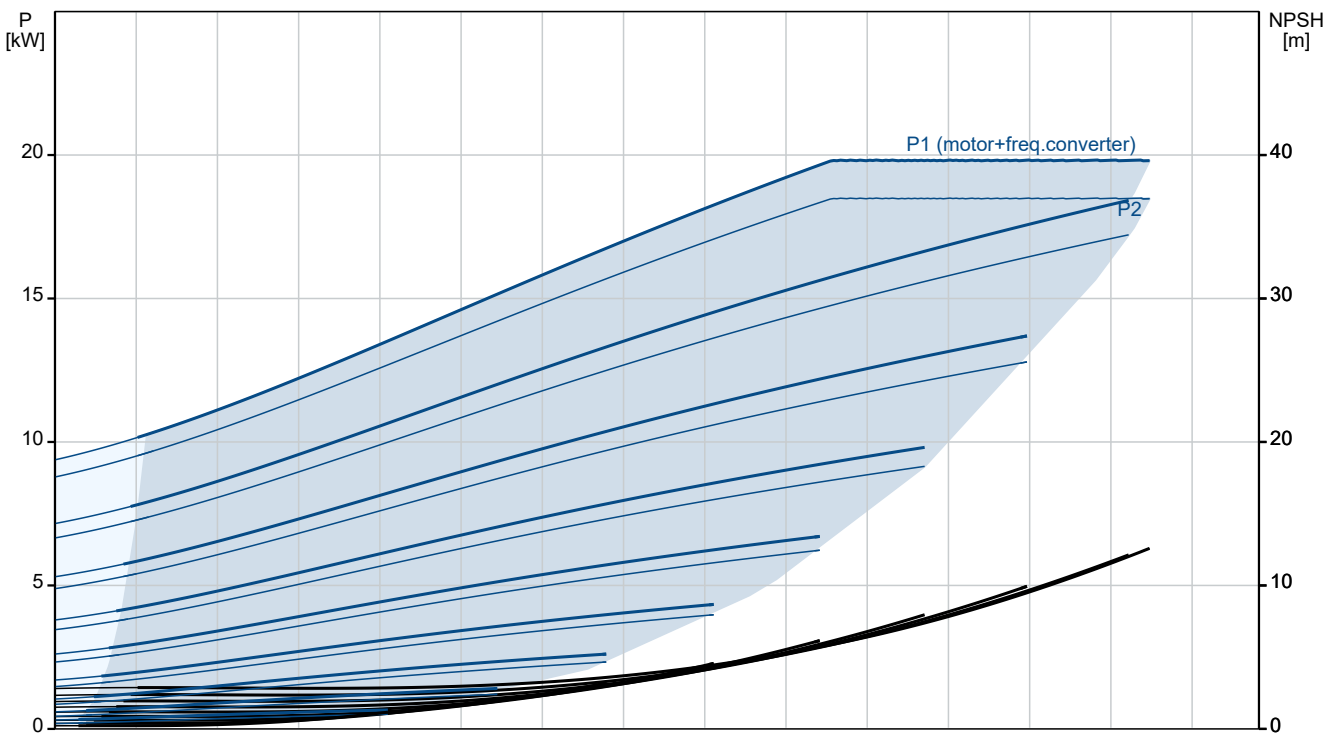

Description	Value
General information:	
Product name:	TPED 50-830/2 S-A-F-A-BAQE-PWB
Product No:	On request
EAN number:	On request
Technical:	
Pump speed on which pump data are based:	2940 rpm
Rated flow:	51.7 m ³ /h
Rated head:	66.3 m
Maximum head:	830 dm
Actual impeller diameter:	245 mm
Code for shaft seal:	BAQE
Curve tolerance:	ISO9906:2012 3B
Pump version:	A
Materials:	
Pump housing:	Cast iron
Pump housing:	EN-GJL-250
Pump housing:	ASTM class 35
Impeller:	Cast iron
Impeller:	EN-GJL-200
Impeller:	ASTM class 30
Material code:	A
Installation:	
Range of ambient temperature:	-20 .. 50 °C
Maximum operating pressure:	16 bar
Max pressure at stated temp:	16 bar / 120 °C
Type of connection:	DIN
Size of connection:	DN 50
Pressure rating for connection:	PN 16
Port-to-port length:	440 mm
Flange size for motor:	FF300
Connect code:	F
Liquid:	
Pumped liquid:	Water
Liquid temperature range:	0 .. 120 °C
Selected liquid temperature:	20 °C
Density:	998.2 kg/m ³
Electrical data:	
Motor type:	160LB
Rated power - P2:	18.5 kW
Mains frequency:	50 / 60 Hz
Rated voltage:	3 x 380-480 V
Rated current:	33.0-27.8 A
Cos phi - power factor:	0.94-0.92
Rated speed:	360-4000 rpm
IE Efficiency class:	IE5
Motor efficiency at full load:	92.8 %
Number of poles:	2
Enclosure class (IEC 34-5):	IP55
Insulation class (IEC 85):	F
Built-in motor protection:	ELEC
Motor No:	92875540
Controls:	
Control panel:	HMI300 - Advanced
Function Module:	FM310 - Advanced
Frequency converter:	Built-in
Others:	

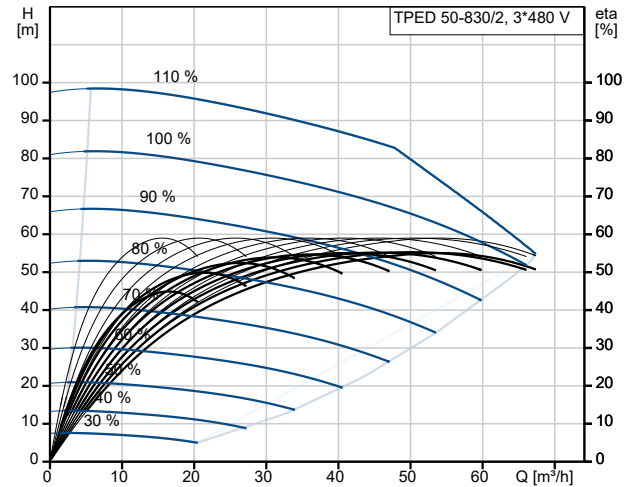

Pumped liquid = Water
Liquid temperature during operation = 20 °C
Density = 998.2 kg/m³

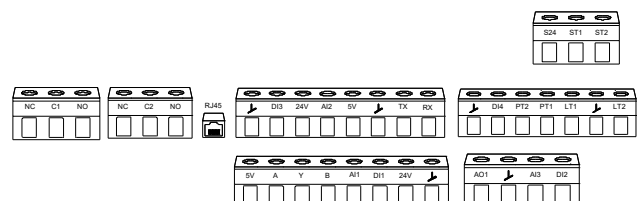
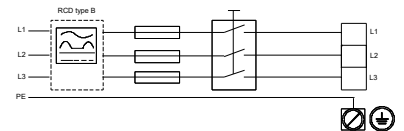
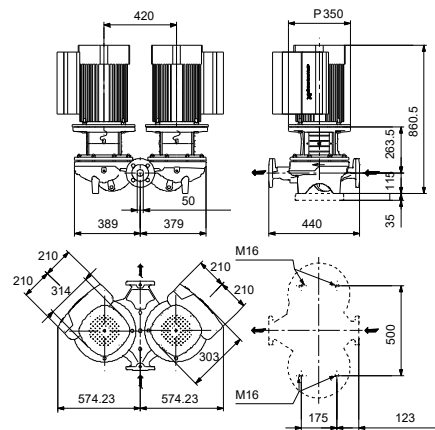
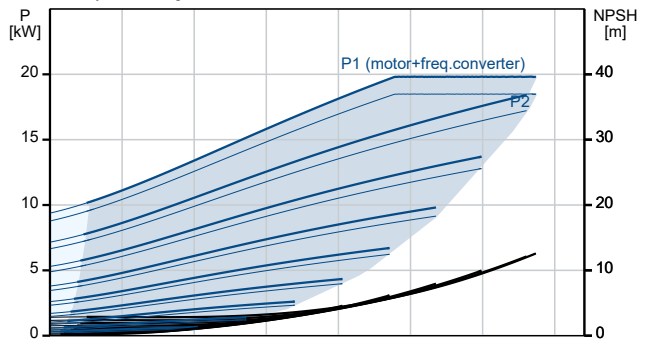



Company name:

Created by:

Phone:

Date:

22/10/2024

Description	Value
Minimum efficiency index, MEI ≥:	0.70
Net weight:	304 kg
Gross weight:	367 kg
Shipping volume:	1.87 m ³
Config. file no:	92956246
Country of origin:	HU
Custom tariff no.:	84137065

On request TPED 50-830/2 S-A-F-A-BAQE-PWB

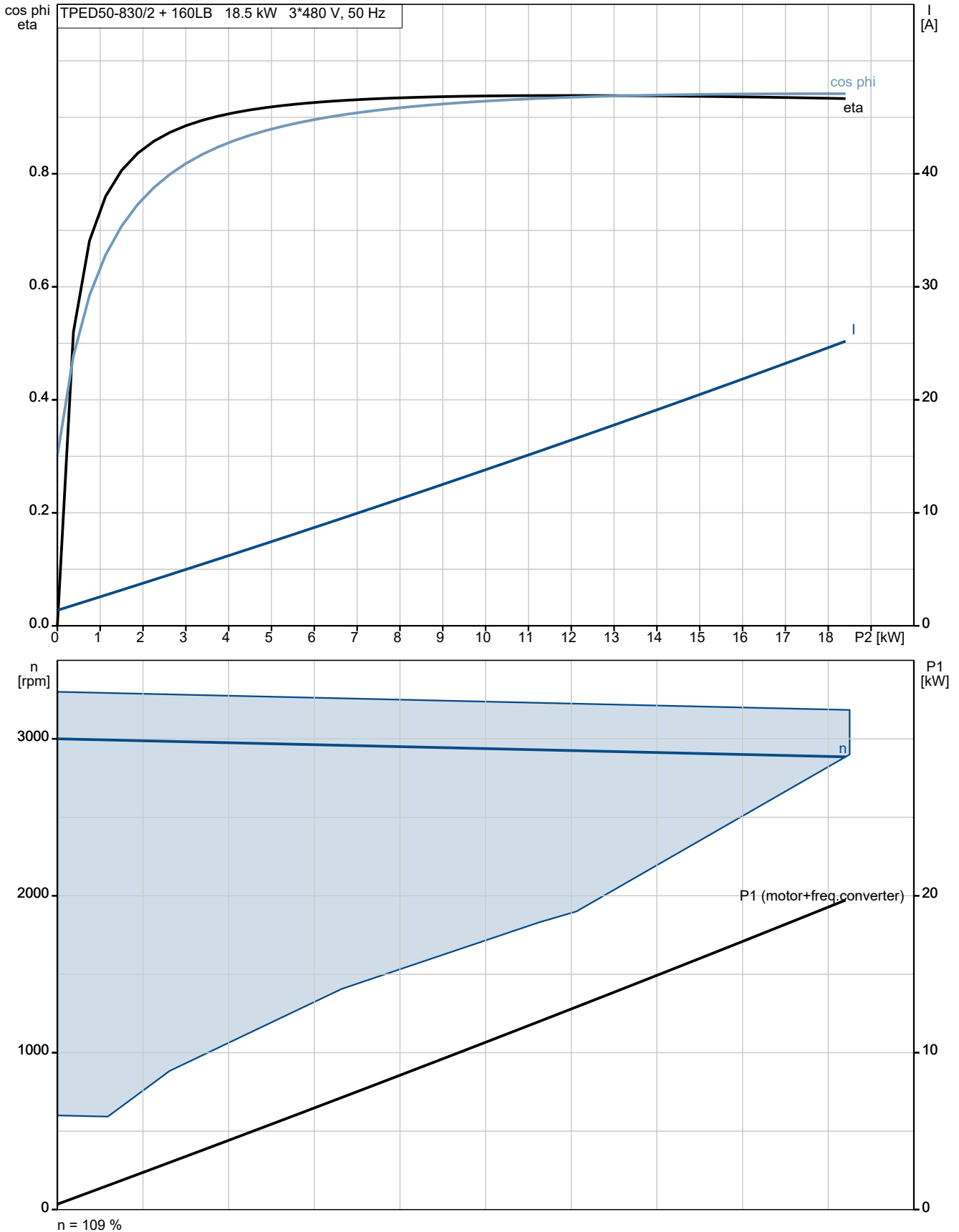

On request TPED 50-830/2 S-A-F-A-BAQE-PWB

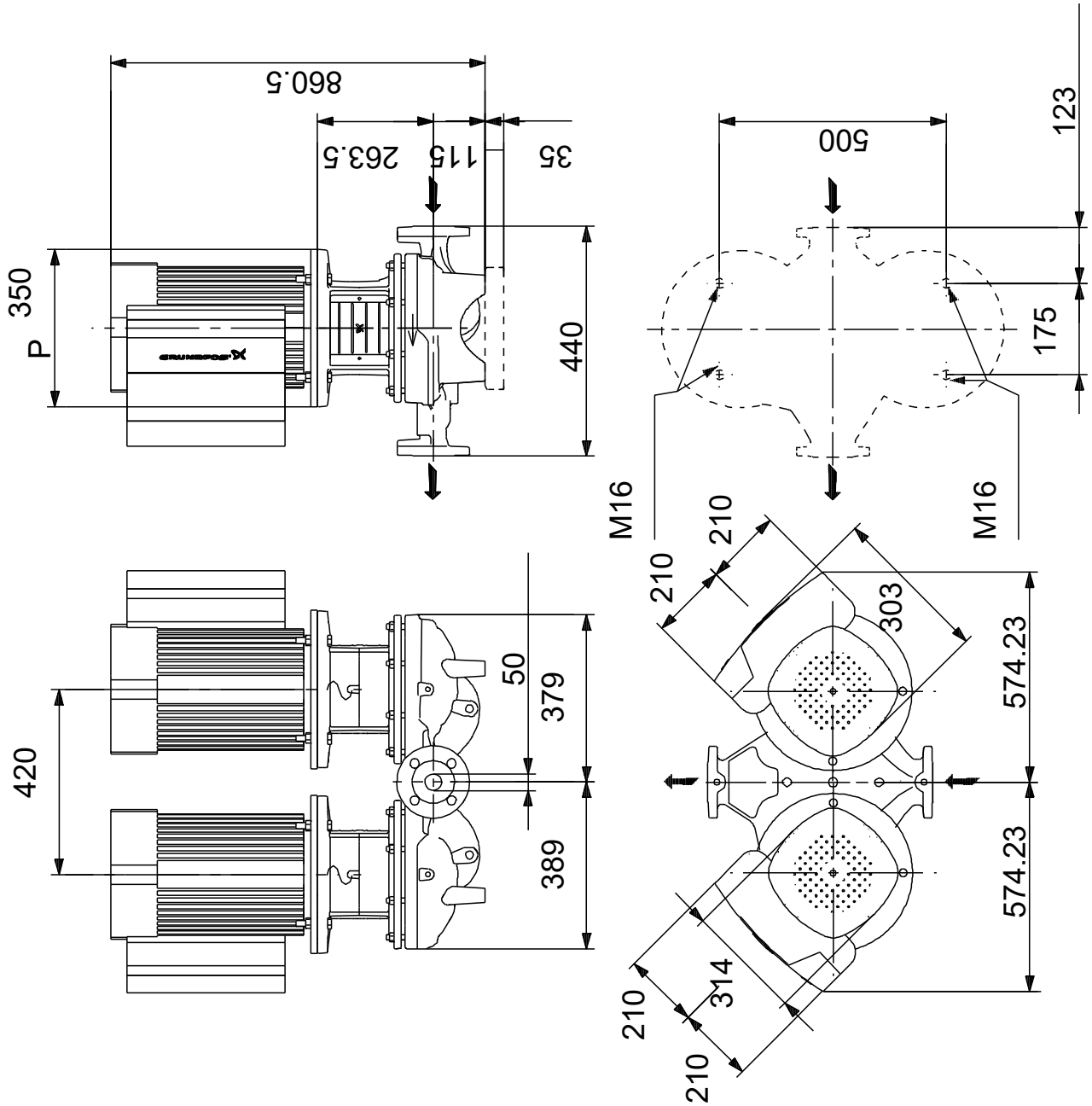

Note! All units are in [mm] unless others are stated.
Disclaimer: This simplified dimensional drawing does not show all details.

On request TPED 50-830/2 S-A-F-A-BAQE-PWB

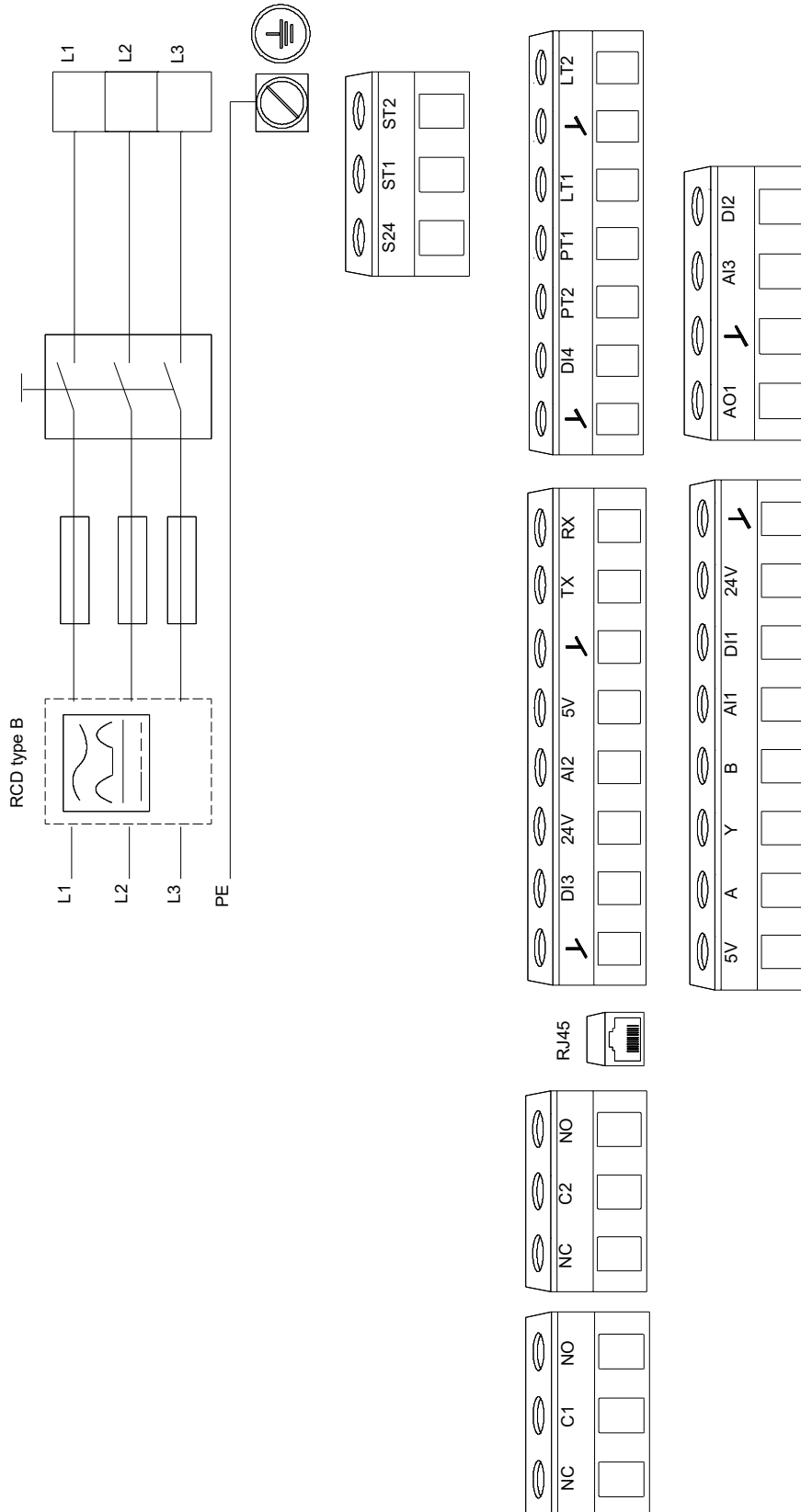

Note! All units are in [mm] unless others are stated.

