

Anz.	Beschreibung
------	--------------

1	OCD-162-60-P/G1
---	-----------------



Hinweis! Abbildung kann vom Produkt abweichen.

Produktnr.: auf Anfr.

Compact pre-mounted generation and dosing system for chlorine dioxide according to sodium chlorite / hydrochloric acid method with chemicals-saving and corrosion-protective 1:1 mixture ratio.

The system is equipped with microprocessor control and integrated measuring amplifier. Therefore the chlorine dioxide solution can be optionally dosed proportional to flow or measurement controlled. Input comes from a contact water meter or a continuous signal from a water meter and a chlorine dioxide measuring cell.

The compact design of the system as floor-standing unit enables easy use and safe, reliable operation. Front installation of all system components makes maintenance fast and less expensive.

Only 7.5 weight-% sodium chlorite solution acc. to DIN EN 938 and 9 weight-% hydrochloric acid acc. to DIN EN 939 shall be used.

A corrosion resistant injection point has to be used to reduce the risk of corrosion in the installation system. Alternatively the optional bypass mixing module from Grundfos is available.

The unit can be supplied as option with an external chlorine dioxide batch tank for additional peak demand.

Scope of delivery:

CIO<sub>2</sub> generation system in floor-standing rack

Two pre-assembled suction lines

Mounting material

Protective cover

Technical data:

Connection for dilution water: hose connector 6/9 mm or PVC pipe DN 8

Connection for CIO<sub>2</sub> dosing: tubing connector 4/6, 6/9 and 9/12 mm

Generator capacity CIO<sub>2</sub>: 60 g/h  
Dosing pump: digital, DDI integriert

Electrical data:

Mains frequency: 50 / 60 Hz

Rated voltage: 230 V

Enclosure class (IEC 34-5): IP65

Sonstiges:

Dimensions (WxHxD, mm): 766 x 1813 x 560

Net weight: 85 kg

Beschreibung	Daten
<b>Allgemeine Informationen:</b>	
Produktbezeichnung:	OCD-162-60-P/G1
Produktnummer:	auf Anfr.
EAN-Nummer:	auf Anfr.
<b>Technische Daten:</b>	
Max. Leistung:	60 l/h
Max. Leistung:	60 g/h
Dosierpumpe:	digital, DDI integriert
Saugleitungen:	60 l
<b>Elektrische Daten:</b>	
Netzfrequenz:	50 / 60 Hz
Bemessungsspannung:	x 230 V
Schutzart (gemäß IEC 34-5):	IP65
<b>Sonstiges:</b>	
Nettogewicht:	85 kg
Herkunftsland:	DE
Zolltarif Nr.:	84798997

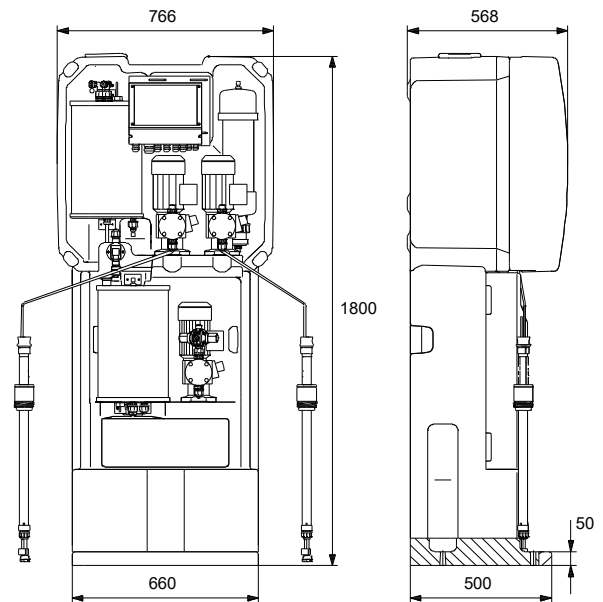

Oxiperm pro 30g

## auf Anfr. OCD-162-60-P/G1

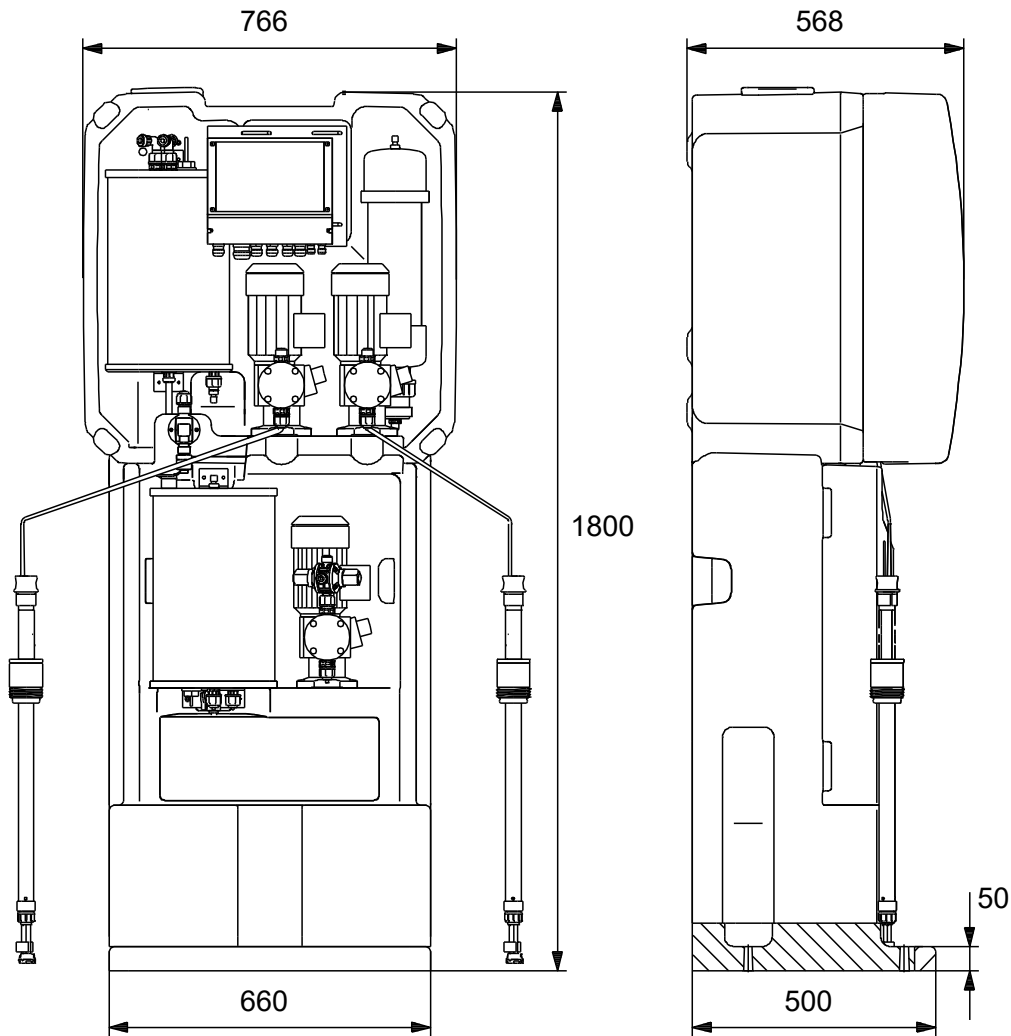

Oxiperm pro 30g

