

Submittal Data

| | | |
|-----------------------|------------------|-------------|
| PROJECT: | UNIT TAG: | QUANTITY: |
| REPRESENTATIVE: _____ | TYPE OF SERVICE: | DATE: _____ |
| ENGINEER: | SUBMITTED BY: | DATE: |
| CONTRACTOR: | APPROVED BY: | DATE: |
| | ORDER NO.: | DATE: |



TP 50-190/2 A-F-A-BQQE-HW1

Grundfos TP pumps are single-stage, close-coupled in-line centrifugal pumps with mechanical shaft seal and primely for applications such as heating/cooling/district energy. The pumps are fitted with fixed speed motors.

Note! Product picture may differ from actual product

| Conditions of Service | Pump Data | Motor Data |
|-----------------------|---|---|
| | Max pressure at stated temp: 16 bar / 120 °C Liquid temperature range: -25 .. 120 °C Maximum ambient temperature: 60 °C Shaft seal: BQQE Product number: On request | Rated voltage: 220-240D/380-415Y V Mains frequency: 50 Hz Enclosure class: 55 Dust/Jetting Insulation class: F Motor protection: NONE Motor type: 90SD Eta 1/1: 84.2-84.2 % |

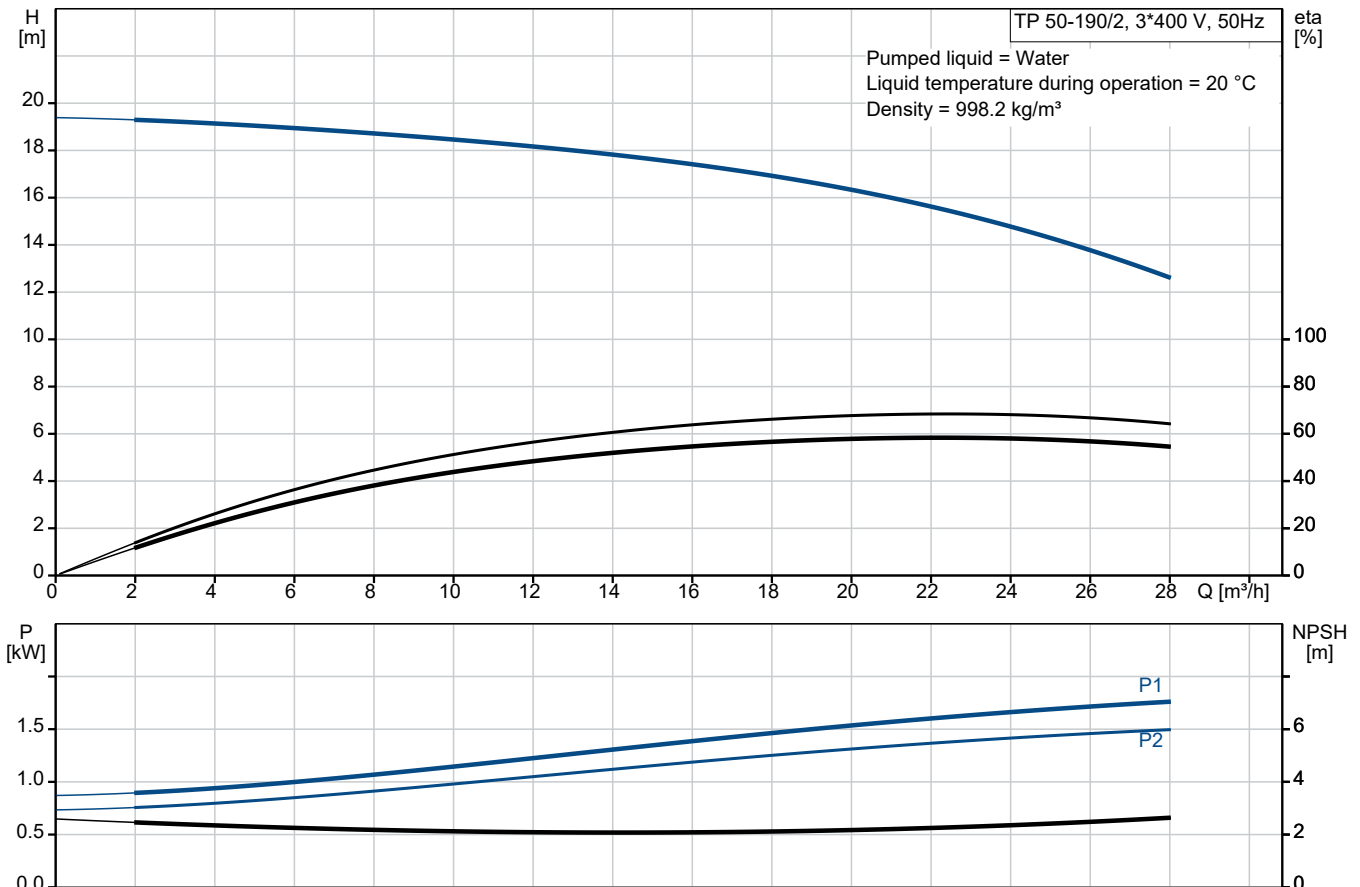

Submittal Data

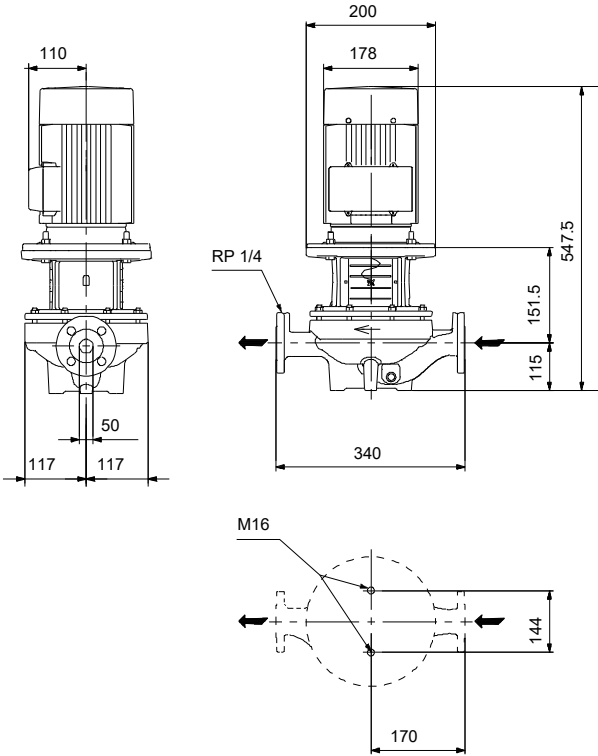

- Materials:**
- Pump housing: Cast iron
 - Pump housing: ASTM class 35
 - Impeller: Cast iron
 - Impeller: ASTM class 30
 - Impeller: EN-GJL-200
 - Material code: A

Qty. Description

1 TP 50-190/2 A-F-A-BQQE-HW1



Note! Product picture may differ from actual product

Product No.: On request

Single-stage, close-coupled, volute pump with in-line suction and discharge ports of identical diameter. The pump is of the top-pull-out design, i.e. the power head (motor, pump head and impeller) can be removed for maintenance or service while the pump housing remains in the pipework.

The pump is fitted with an unbalanced rubber bellows seal. The shaft seal is according to EN 12756. Pipework connection is via PN 16 DIN flanges (EN 1092-2 and ISO 7005-2).

The pump is fitted with a fan-cooled asynchronous motor.

The product's minimum efficiency index (MEI) is greater or equal to 0.70. This is by the Commission Regulation (EU) considered as an indicative benchmark for best-performing water pump available on the market as from 1 January 2013.

Cast-iron parts have an epoxy-based coating made in a cathodic electro-deposition (CED) process. CED is a high-quality dip-painting process where an electrical field around the products ensures deposition of paint particles as a thin, well-controlled layer on the surface.

Pump



- 1: Pump housing
- 2: Impeller
- 3: Stub shaft
- 4: Pump head/motor stool
- 5: Wear rings

The pump housing is provided with a replaceable brass neck ring to reduce the amount of liquid running from the outlet side of the impeller to the inlet side.

The impeller is secured to the shaft with a nut.

The pump is fitted with an unbalanced rubber bellows seal with torque transmission across the spring and around the bellows. Due to the bellows, the seal does not wear the shaft, and the axial movement is not prevented by deposits on the shaft.

Seal faces:

- Rotating seal ring material: silicon carbide (SiC)
- Stationary seat material: silicon carbide (SiC)

This material pairing is used where higher corrosion resistance is required. The high hardness of this material pairing offers good resistance against abrasive particles.

Secondary seal material: EPDM (ethylene-propylene rubber)

Qty. Description

| | |
|---|---|
| 1 | <p>EPDM has excellent resistance to hot water. EPDM is not suitable for mineral oils.</p> <p>A circulation of liquid through the duct of the air vent screw ensures lubrication and cooling of the shaft seal. The flanges have tappings for mounting of pressure gauges.</p> <p>The motor stool forms connection between the pump housing and the motor, and is equipped with a manual air vent screw for venting of the pump housing and the shaft seal chamber. The sealing between motor stool and pump housing is an O-ring.</p> <p>The central part of the motor stool is provided with guards for protection against the shaft and coupling. The pump shaft is fastened directly on the motor shaft with key and set screws.</p> <p>Motor</p> <p>The motor is a totally enclosed, fan-cooled motor with principal dimensions to IEC and DIN standards. Electrical tolerances comply with IEC 60034.</p> <p>The motor is flange-mounted with free-hole flange (FF).</p> <p>Motor-mounting designation in accordance with IEC 60034-7: IM B 5, IM V 1 (Code I) / IM 3001, IM 3011 (Code II).</p> <p>The motor efficiency is classified as IE3 in accordance with IEC 60034-30-1.</p> <p>The motor does not incorporate motor protection and must be connected to a motor-protective circuit breaker which can be manually reset. The motor-protective circuit breaker must be set according to the rated current of the motor (I1/I).</p> <p>The motor can be connected to a variable speed drive for adjustment of pump performance to any duty point. Grundfos CUE offers a range of variable speed drives. Please find more information in Grundfos Product Center.</p> <p>Further product details</p> <p>Cast-iron parts have an epoxy-based coating made in a cathodic electro-deposition (CED) process. CED is a high-quality dip-painting process where an electrical field around the products ensures deposition of paint particles as a thin, well-controlled layer on the surface.</p> <p>Technical data</p> <p>Controls:</p> <p>Frequency converter: None</p> <p>Liquid:</p> <p>Liquid temperature range: -25 .. 120 °C</p> <p>Technical:</p> <p>Pump speed on which pump data are based: 2900 rpm</p> <p>Rated flow: 22.2 m³/h</p> <p>Rated head: 15.5 m</p> <p>Actual impeller diameter: 120 mm</p> <p>Code for shaft seal: BQQE</p> <p>Curve tolerance: ISO9906:2012 3B2</p> <p>Materials:</p> <p>Pump housing: Cast iron EN-GJL-250 ASTM class 35</p> <p>Impeller: Cast iron EN-GJL-200 ASTM class 30</p> <p>Installation:</p> <p>Range of ambient temperature: -30 .. 60 °C</p> <p>Maximum operating pressure: 16 bar</p> <p>Max pressure at stated temp: 16 bar / 120 °C</p> <p>Type of connection: DIN</p> <p>Size of connection: DN 50</p> |
|---|---|

Qty. Description

| | |
|---|--|
| 1 | <p>Pressure rating for connection: PN 16 Port-to-port length: 340 mm Flange size for motor: FF165</p> <p>Electrical data: Motor type: 90SD Rated power - P2: 1.5 kW Mains frequency: 50 Hz Rated voltage: 3 x 220-240D/380-415Y V Rated current: 5.70/3.30 A Starting current: 750-820 % Rated speed: 2890-2910 rpm IE Efficiency class: IE3 Motor efficiency at full load: 84.2-84.2 % Motor efficiency at 3/4 load: 86.4-84.9 % Motor efficiency at 1/2 load: 86.0-83.0 % Number of poles: 2 Enclosure class (IEC 34-5): 55 Dust/Jetting Insulation class (IEC 85): F Motor No: 99583820</p> <p>Others: Minimum efficiency index, MEI ≥: 0.70 Net weight: 49.3 kg Gross weight: 61 kg Shipping volume: 0.217 m³ Danish VVS No.: 381703190 Finnish LVI No.: 4616054 Norwegian NRF no.: 9043553 Country of origin: HU Custom tariff no.: 84137051</p> |
|---|--|

On request TP 50-190/2 A-F-A-BQQE-HW1 50 Hz

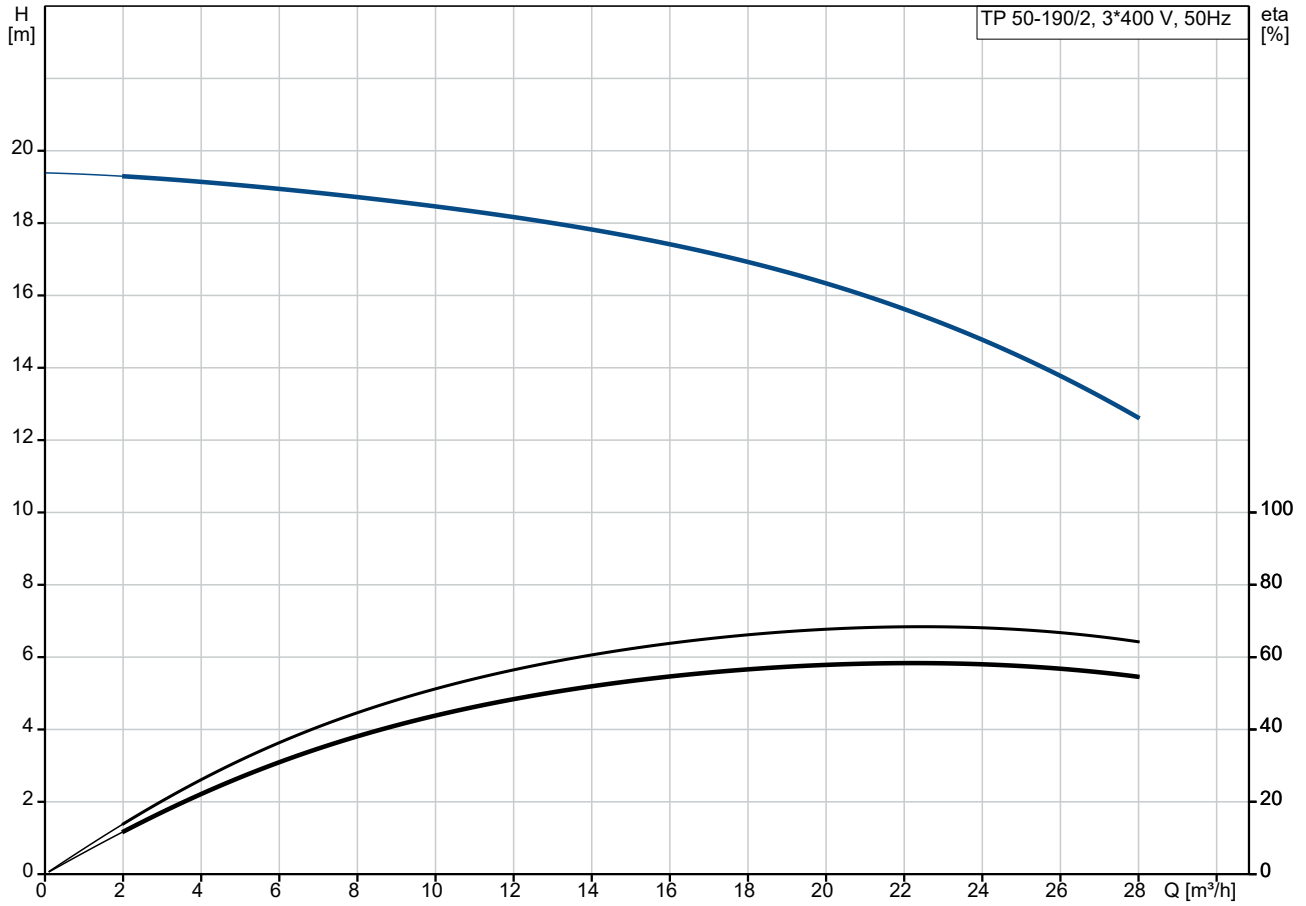

Pumped liquid = Water
 Liquid temperature during operation = 20 °C
 Density = 998.2 kg/m³

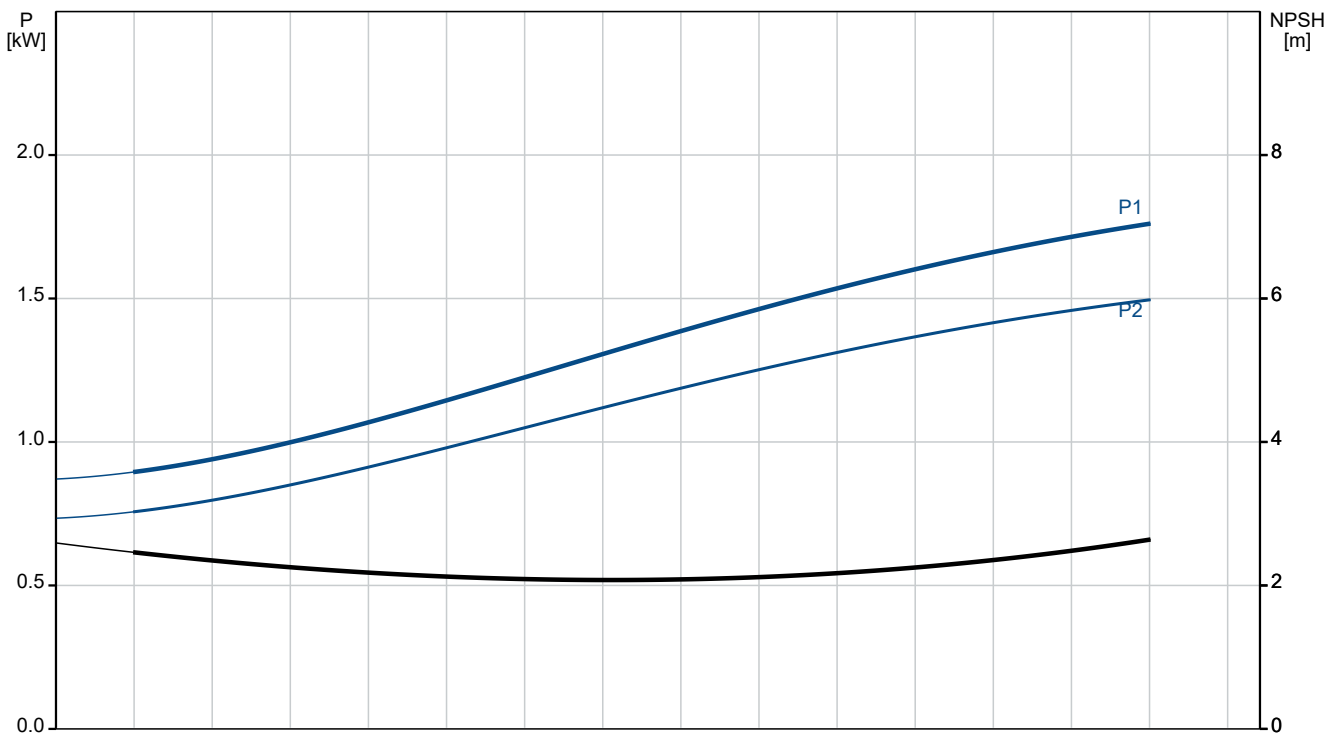

| Description | Value |
|--|-------------------------------|
| General information: | |
| Product name: | TP 50-190/2 A-F-A-BQQE-HW1 |
| Product No: | On request |
| EAN number: | On request |
| Technical: | |
| Pump speed on which pump data are based: | 2900 rpm |
| Rated flow: | 22.2 m ³ /h |
| Rated head: | 15.5 m |
| Maximum head: | 190 dm |
| Actual impeller diameter: | 120 mm |
| Code for shaft seal: | BQQE |
| Curve tolerance: | ISO9906:2012 3B2 |
| Pump version: | A |
| Materials: | |
| Pump housing: | Cast iron |
| Pump housing: | EN-GJL-250 |
| Pump housing: | ASTM class 35 |
| Impeller: | Cast iron |
| Impeller: | EN-GJL-200 |
| Impeller: | ASTM class 30 |
| Material code: | A |
| Installation: | |
| Range of ambient temperature: | -30 .. 60 °C |
| Maximum operating pressure: | 16 bar |
| Max pressure at stated temp: | 16 bar / 120 °C |
| Type of connection: | DIN |
| Size of connection: | DN 50 |
| Pressure rating for connection: | PN 16 |
| Port-to-port length: | 340 mm |
| Flange size for motor: | FF165 |
| Connect code: | F |
| Liquid: | |
| Liquid temperature range: | -25 .. 120 °C |
| Electrical data: | |
| Motor type: | 90SD |
| Rated power - P2: | 1.5 kW |
| Mains frequency: | 50 Hz |
| Rated voltage: | 3 x 220-240D/380-415Y V |
| Rated current: | 5.70/3.30 A |
| Starting current: | 750-820 % |
| Rated speed: | 2890-2910 rpm |
| IE Efficiency class: | IE3 |
| Motor efficiency at full load: | 84.2-84.2 % |
| Motor efficiency at 3/4 load: | 86.4-84.9 % |
| Motor efficiency at 1/2 load: | 86.0-83.0 % |
| Number of poles: | 2 |
| Enclosure class (IEC 34-5): | 55 Dust/Jetting |
| Insulation class (IEC 85): | F |
| Built-in motor protection: | NONE |
| Motor No: | 99583820 |
| Controls: | |
| Frequency converter: | None |
| Others: | |
| Minimum efficiency index, MEI ≥: | 0.70 |
| Net weight: | 49.3 kg |
| Gross weight: | 61 kg |

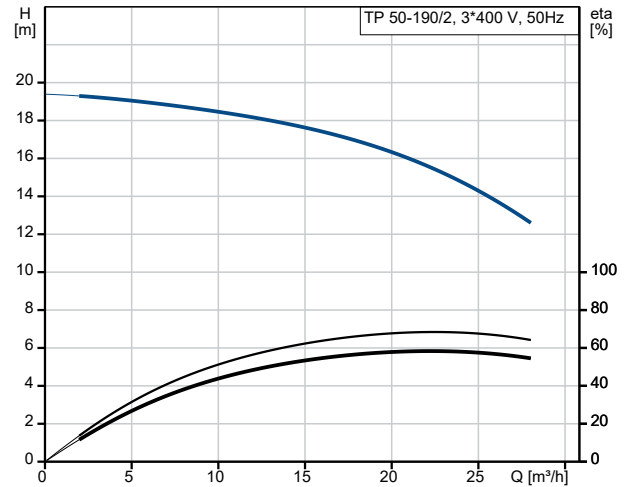

Pumped liquid = Water
Liquid temperature during operation = 20 °C
Density = 998.2 kg/m³

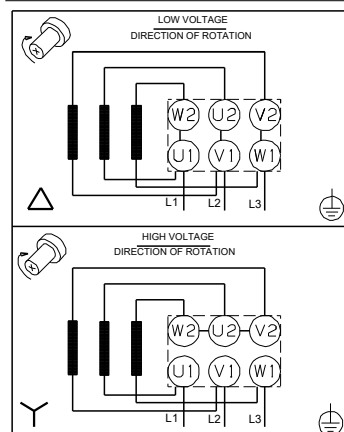
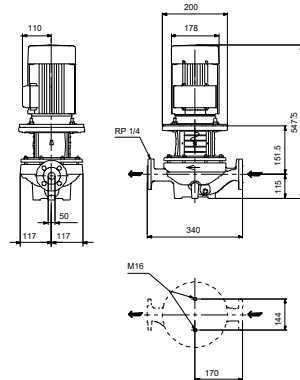
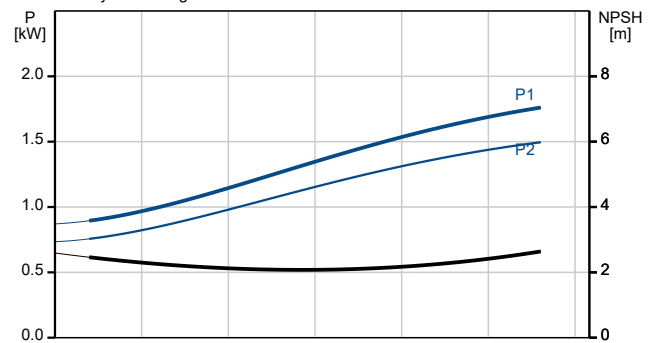



Company name:

Created by:

Phone:

Date:

30/11/2023

| Description | Value |
|--------------------|----------------------|
| Shipping volume: | 0.217 m ³ |
| Danish VVS No.: | 381703190 |
| Finnish LVI No.: | 4616054 |
| Norwegian NRF no.: | 9043553 |
| Country of origin: | HU |
| Custom tariff no.: | 84137051 |

On request TP 50-190/2 A-F-A-BQQE-HW1 50 Hz

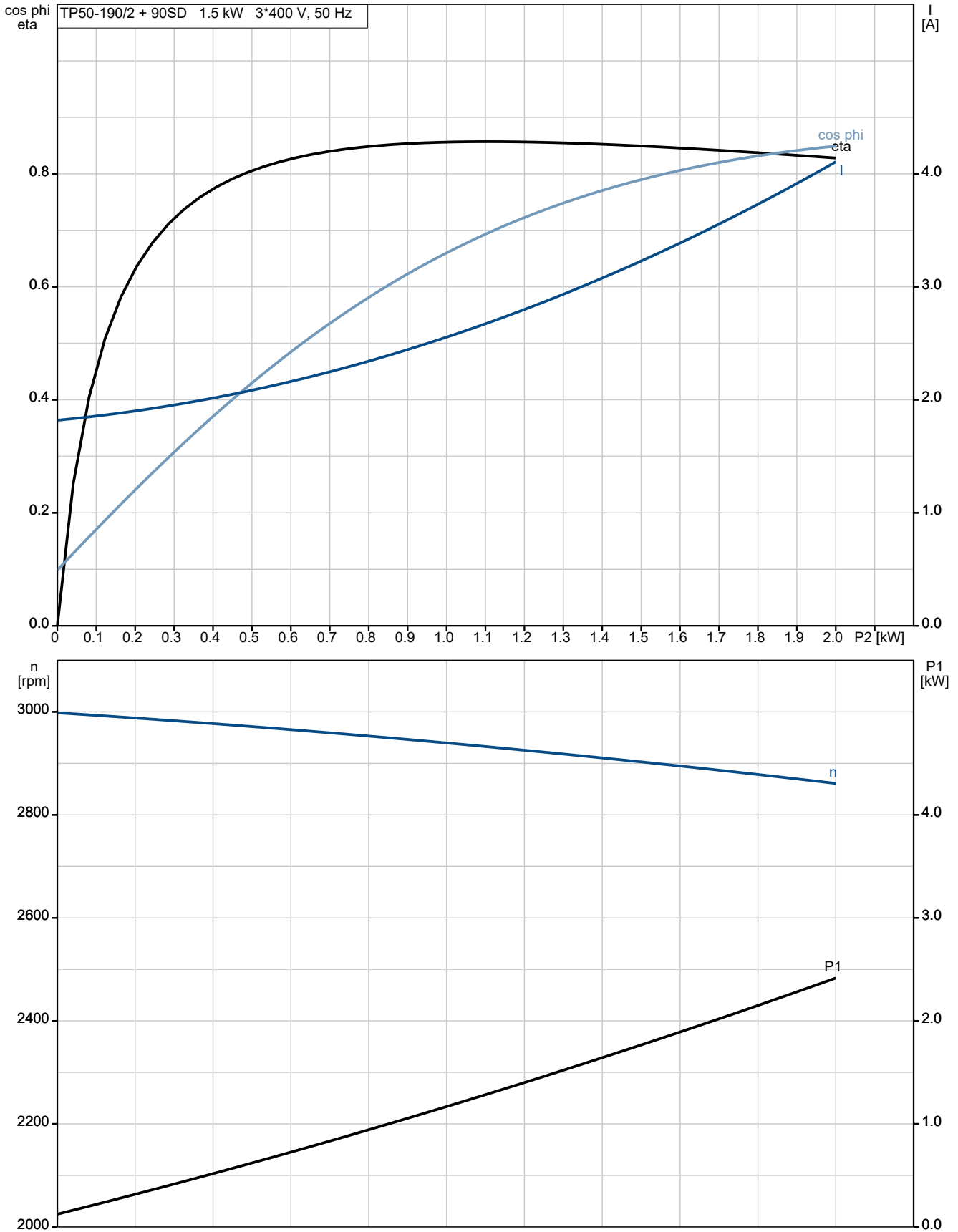

On request TP 50-190/2 A-F-A-BQQE-HW1 50 Hz

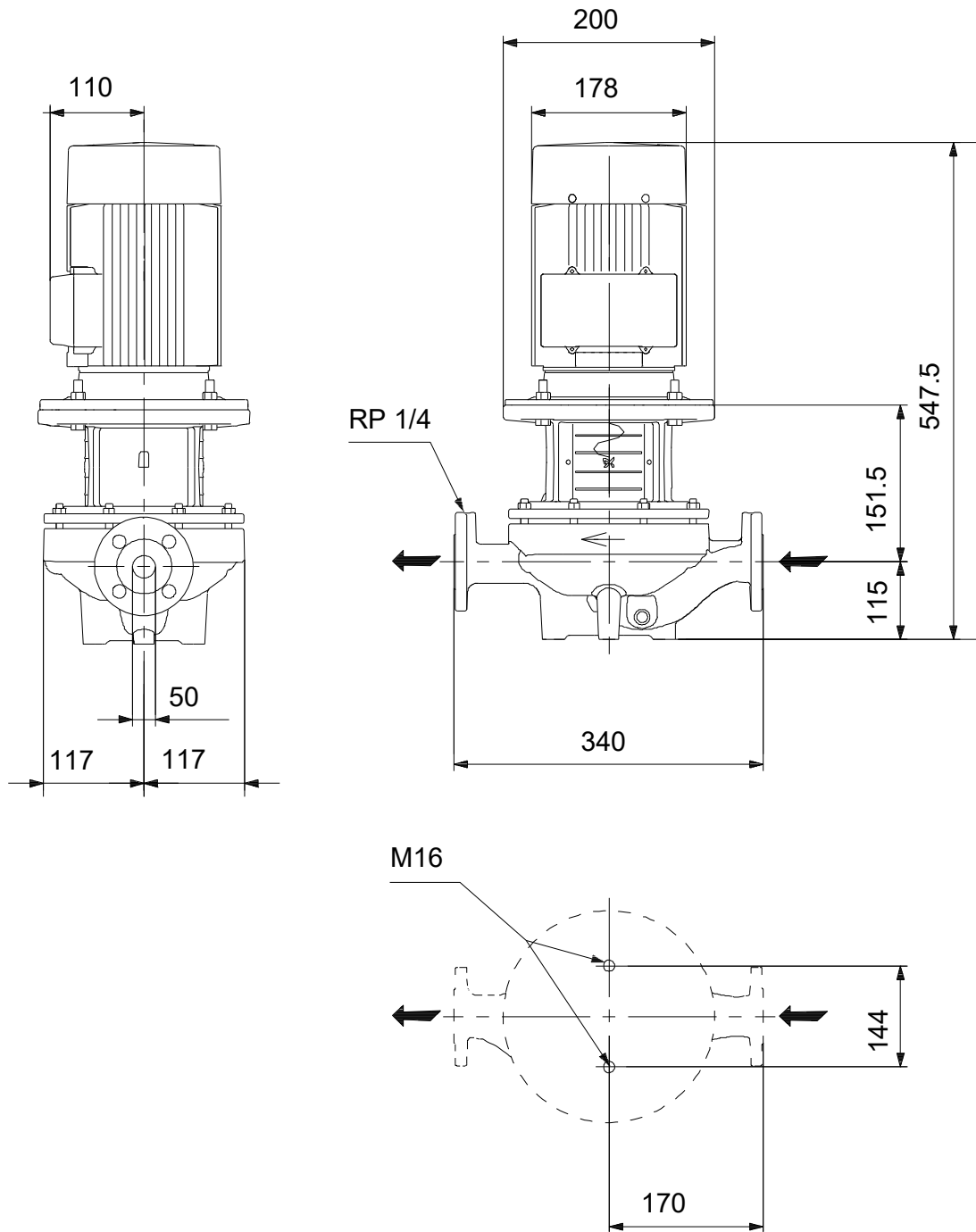

Note! All units are in [mm] unless others are stated.
Disclaimer: This simplified dimensional drawing does not show all details.

On request TP 50-190/2 A-F-A-BQQE-HW1 50 Hz

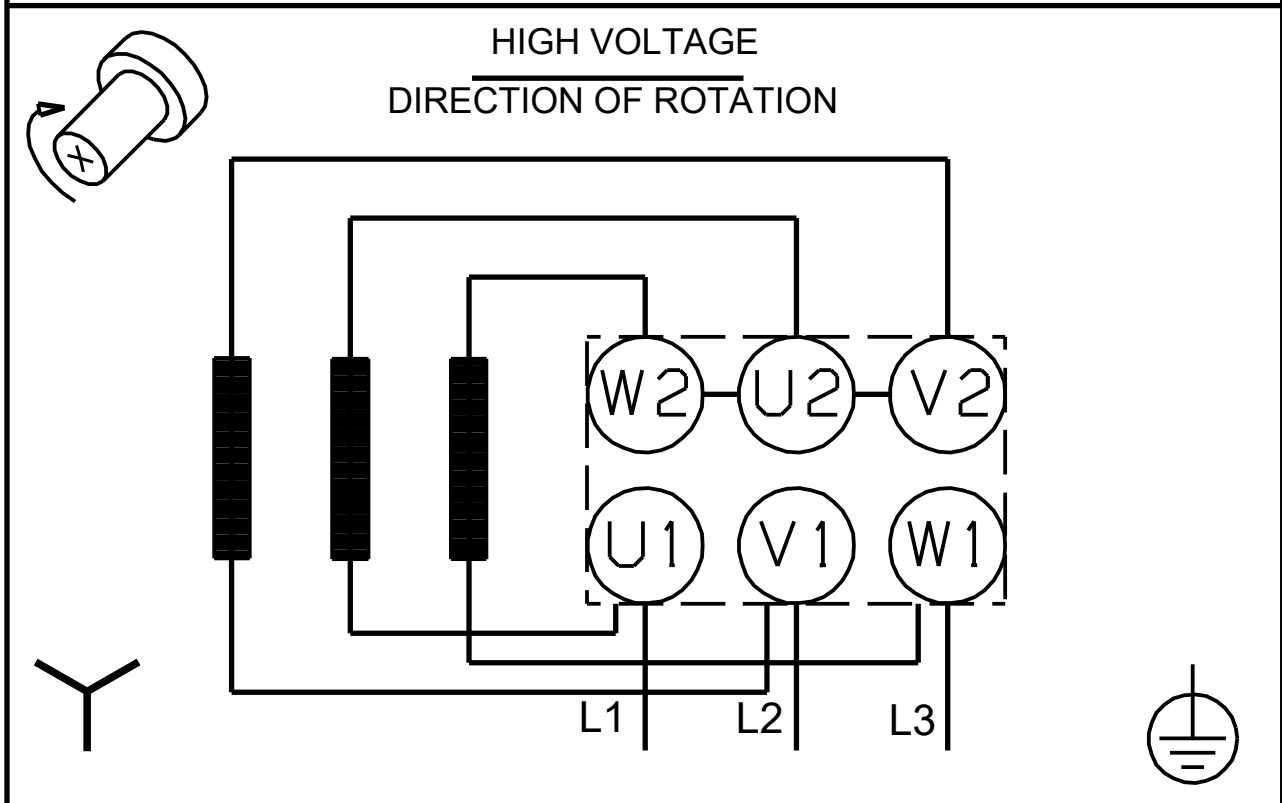
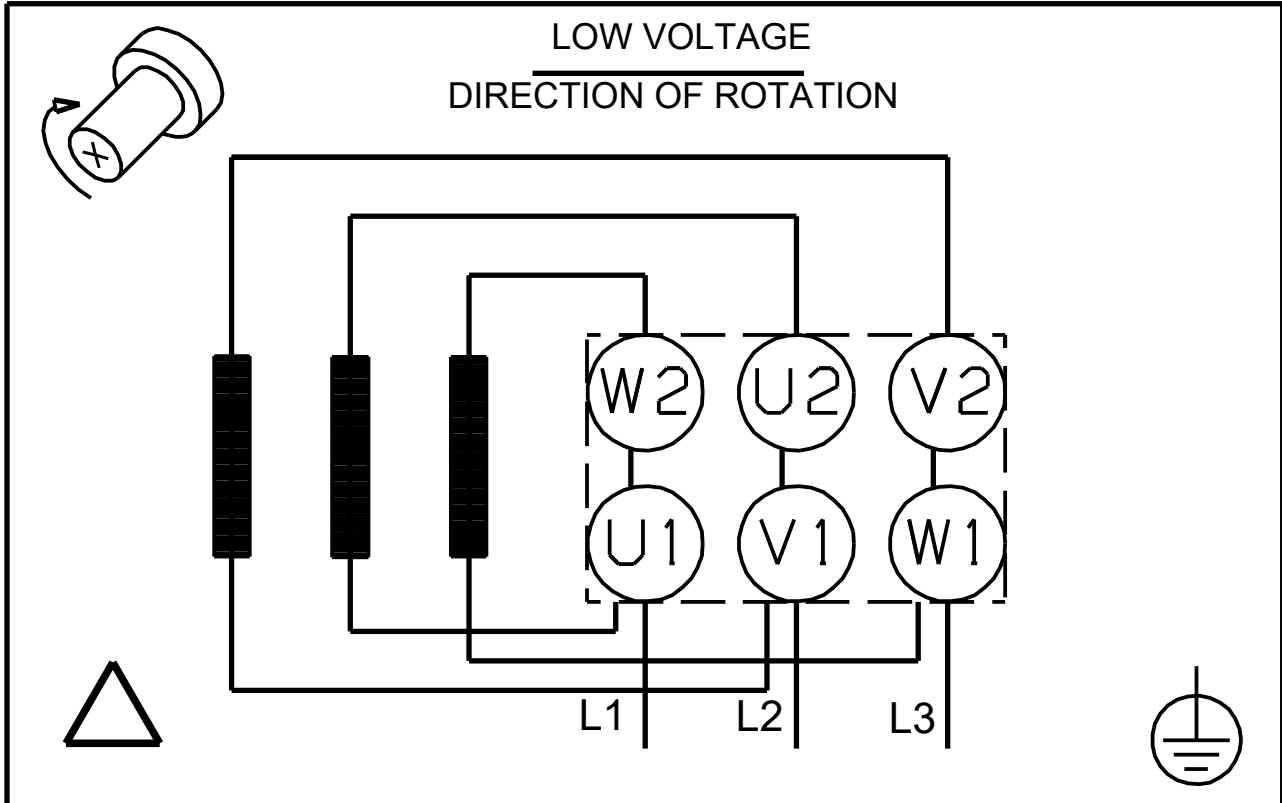

Note! All units are in [mm] unless others are stated.

