

Qty. Description

1 **Auto coupling set**



Note! Product picture may differ from actual product

Product No.: On request

This accessory is used for submersed installation of Grundfos wastewater pumps.

This set consists of:

- Baseplate
- Guide claw*
- Upper guide rail holder (Guide rails are not included)
- Bolts and gasket for mounting the guide claw to the pump, when needed.

* For S-pumps with outlet flange size DN 250 and above, the guide claw is fitted to the pump from the factory.

Materials:

Material: Cast iron
EN-GJL-250
ASTM A48 Class 250B

Surface treatment: Powder coated

Gasket: Rubber
NBR

Installation:

Maximum operating pressure: 10 bar

Type of inlet connection: DIN

Type of outlet connection: DIN

Size of inlet connection: DN 100

Size of outlet connection: DN 150

Flange pressure class: PN10/16

Flange standard: DIN EN 1092-1

Number of anchor bolts: 0

Number of base units: 1

Number of washers: 0

Number of nuts: 0

Number of gaskets: 1

Number of profile gaskets: 1

Number of guide claws: 1

Number of screws: 8

Number of guide rail holders: 1

Others:

Net weight: 94.2 kg

Gross weight: 94.2 kg

Shipping volume: 0.168 m³

Fits to following products: SE/SL



Company name:

Created by:

Phone:

Date:

21/10/2024

Qty.	Description
------	-------------

1	Danish VVS No.: 391299717 Country of origin: PL Custom tariff no.: 84139100
---	---

Description	Value
General information:	
Product name:	Auto coupling set
Product No:	On request
EAN number:	On request
Materials:	
Material:	Cast iron
Material:	EN-GJL-250
Material:	ASTM A48 Class 250B
Surface treatment:	Powder coated
Gasket:	Rubber
Gasket:	NBR
Installation:	
Maximum operating pressure:	10 bar
Type of inlet connection:	DIN
Type of outlet connection:	DIN
Size of inlet connection:	DN 100
Size of outlet connection:	DN 150
Flange pressure class:	PN10/16
Flange standard:	DIN EN 1092-1
Number of anchor bolts:	0
Number of base units:	1
Number of washers:	0
Number of nuts:	0
Number of gaskets:	1
Number of profile gaskets:	1
Number of guide claws:	1
Number of screws:	8
Number of guide rail holders:	1
Others:	
Net weight:	94.2 kg
Gross weight:	94.2 kg
Shipping volume:	0.168 m ³
Fits to following products:	SE/SL
Danish VVS No.:	391299717
Country of origin:	PL
Custom tariff no.:	84139100

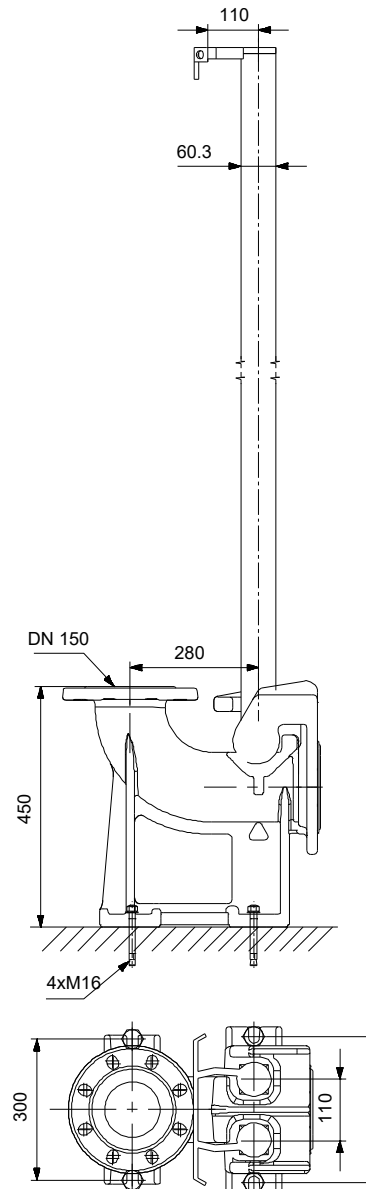

On request Auto coupling set

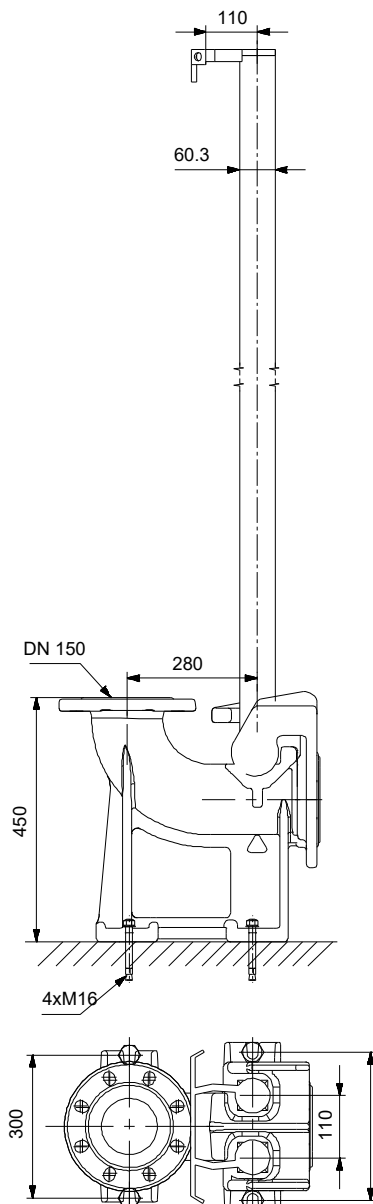

Note! All units are in [mm] unless others are stated.
Disclaimer: This simplified dimensional drawing does not show all details.

