

Qty.	Description
1	<p>MD1.80.80.22.4.50D /450.SE</p>  <p style="text-align: center;">Note! Product picture may differ from actual product</p> <p>Product No.: On request</p> <p>Supplied as complete unit ready for installation, MULTILIFT consist of a compact wastewater lifting station with one or two 450 litre collecting tanks, two horizontal submersible sewage pumps of the SE range, controller including analogue level sensor and connection accessories.</p> <p>The 450 liter tank is made of airtight, corrosion-free polyethylene and is completely gas- and odour-proof. The tank is supplied with the following:</p> <ul style="list-style-type: none">- three horizontal inlet sockets DN150 with one socket seal- vertical inlet connecting piece DN100- vertical connecting piece DN75 for venting with flexible connection piece and clamps- two horizontal connecting pieces DN40 with one connection piece and clamps for manually operated diaphragm pump(s) (accessory). <p>The tank is designed with an inner patented chamfer and suction bends to avoid sedimentation and to reduce residual water.</p> <p>In case of additional collecting tank, 4 connection sockets DN150 are placed at the sides.</p> <p>Horizontal sewage pumps are equipped with a single channel impeller or Vortex impeller. Moreover, these sewage pumps offer:</p> <ul style="list-style-type: none">- free passage up to 80 mm for reliable and blockage-free operation- a unique clamp system to dismantle hydraulic and motor within a minute- a watertight stainless-steel cable plug for easy maintenance and service- double shaft seal cartridge for easy maintenance and service- motor with thermal switches inside the winding- patented cooling system for continuous duty at SE range- motor with thermal switches inside the winding <p>Isolating valves, non-return valves, discharge pipes, a manually operated diaphragm pump, bolts and gaskets as well as a third 450-litre tank are available as accessories.</p> <p>The LC 231 or LC 241 level controllers offer a comprehensive range of features for control and monitoring of pumps in MULTILIFTS.</p> <p>The controllers are designed for level control, monitoring and protection of Grundfos lifting stations with one or two pumps.</p> <p>An analogue level sensor is integrated into the controller and connected to the sensor tube by an air hose.</p> <p>The controller is pre-set from factory to the lowest possible starting level. Adjustment to a higher starting level can be done with the Grundfos GO app.</p> <p>With the Grundfos GO app, all detailed pump settings can be easily configured, monitored and commissioned. The display also offers the possibility to change the operating mode from auto to manual start/stop. The controller is equipped with configurable input/output terminals.</p>



Company name:

Created by:

Phone:

Date: 29/11/2023

Project:
Reference Number:

Client:
Client Number:
Contact:

Qty.	Description
1	<p>The controller integrates seamlessly into the Grundfos range of communication modules, ensuring an easy fit into any supervisory system such as SCADA or Grundfos CLOUD.</p> <p>With the built-in motor protection, and the current measurement, the LC controller provide a service indicator function that helps keep track of when service is needed.</p> <p>The controller maintains a detailed alarm and warning log with the last 20 alerts.</p> <p>The alarm log can be accessed remotely via SCADA or Grundfos CLOUD. You can also use Grundfos GO to inspect the logs in localized, translated text for easy troubleshooting and remedial measures at the pumping station.</p> <p>Configurable input/output terminals that can be used as digital input/output, analogue input.</p> <p>Prevent the mains load when several pumping stations are started up at the same time with power-on delay.</p> <ul style="list-style-type: none">- Selection of automatic alarm resetting- Setting of stop delays matching the actual operating conditions- Shows the actual liquid level- Alarm indication via a build in buzzer- Alarm indication of:<ul style="list-style-type: none">- Power/current overload- High water level- Optional high water level alarm (needs additional level switch)- Incorrect phase sequences or missing phase- Sensor inconsistency or failure- Intrusion detection- Water on floor- Too many restarts- Pump overheating and moisture detection <p>The MULTILIFT range is designed according to the EN12050-1 standard, approved and monitored by external institute LGA. Further approvals are VDE, GHOST, CB, EMV</p> <p>Technical:</p> <p>Pump speed on which pump data are based: 1445 rpm</p> <p>Rated flow: 5.5 l/s</p> <p>Maximum flow: 26.1 l/s</p> <p>Rated head: 11.2 m</p> <p>Type of impeller: SINGLE CHANNEL</p> <p>Max. Particle: 80 mm</p> <p>Primary shaft seal: SIC/SIC</p> <p>Max. hydraulic efficiency: 63 %</p> <p>Approvals: CE,EAC,MORO,UKCA,SEPRO</p> <p>Materials:</p> <p>Pump housing: Cast iron EN 1561 EN-GJL-200 ASTM A48-30A</p> <p>Impeller: Cast iron EN 1561 EN-GJL-200 ASTM A48-30A</p> <p>Tank: PLASTIC LDPE</p> <p>Installation:</p> <p>Range of ambient temperature: 0 .. 40 °C</p> <p>Maximum operating pressure: 10 bar</p>



Company name:

Created by:

Phone:

Date: 29/11/2023

Project:

Reference Number:

Client:

Client Number:

Contact:

Qty.	Description
1	Type of outlet connection: DIN Size of outlet connection: DN 80 Pressure rating for connection: PN 10 Maximum installation depth: 2 m Liquid: Liquid temperature range: 0 .. 40 °C Density: 998.2 kg/m ³ Electrical data: Power input P1: 2.9 kW Rated power - P2: 2.2 kW Mains frequency: 50 Hz Rated voltage: 3 x 380-415 V Voltage tolerance: +6/-10 % Max starts per hour: 60 Rated current: 5.9 A Rated current at 3/4 load: 4.8 A Rated current at 1/2 load: 4.2 A Starting current: 32 A Rated current at no load: 3.6 A Cos phi - power factor: 0.74 Cos phi - p.f. at no load: 0.13 Cos phi - p.f. at 3/4 load: 0.66 Cos phi - p.f. at 1/2 load: 0.53 Locked-rotor torque: 32 Nm Breakdown torque: 45 Nm Moment of inertia: 0.057 kg m ² Motor efficiency at full load: 76.3 % Motor efficiency at 3/4 load: 75.2 % Motor efficiency at 1/2 load: 70.9 % Number of poles: 4 Start. method: direct-on-line Enclosure class (IEC 34-5): IP68 Insulation class (IEC 85): F Built-in motor protection: THERMAL SWITCH Power cable type: H07RN-F Length of power cable: 10 m Controls: Moisture sensor: without moisture sensors Water-in-oil sensor: without water-in-oil sensor Tank: Total effective volume of collecting tank at 180 mm inlet: 120 l Total effective volume of collecting tank at 250 mm inlet: 240 l Tank volume nominal: 450 l Others: Net weight: 307 kg Gross weight: 382 kg Shipping volume: 2.27 m ³ Danish VVS No.: 154033222 Norwegian NRF no.: 9045376



Company name:

Created by:

Phone:

Date: 29/11/2023

Project:

Reference Number:

Client:

Client Number:

Contact:

Qty.	Description
1	Country of origin: DE Custom tariff no.: 84137021 Environmental approvals: WEEE



Company name:
Created by:
Phone:

Date: 29/11/2023

Project:
Reference Number:

Client:
Client Number:
Contact:

On request MD1.80.80.22.4.50D /450.SE 50 Hz

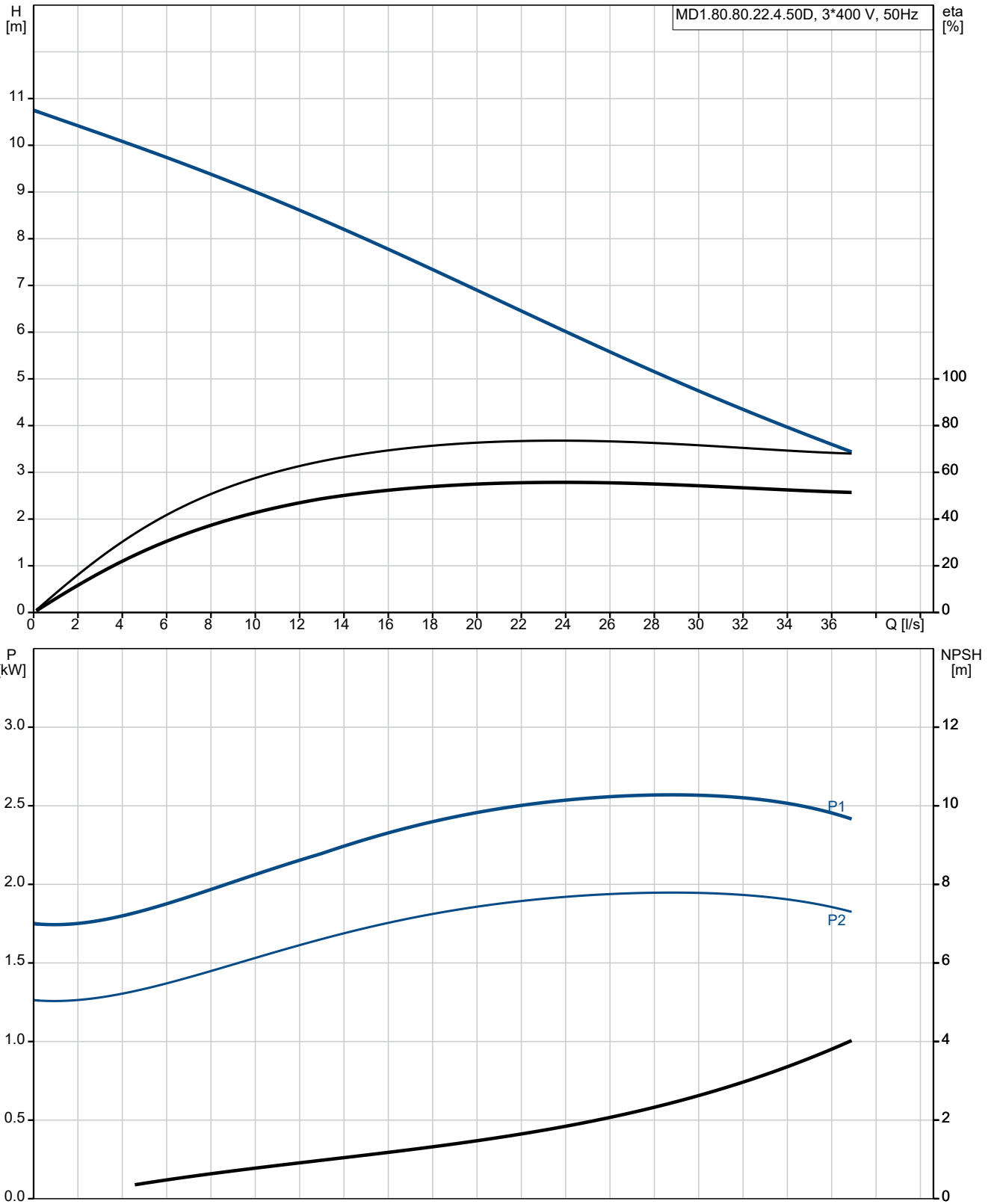



Company name:

Created by:

Phone:

Date: 29/11/2023

Project:

Reference Number:

Client:

Client Number:

Contact:

Description	Value
Breakdown torque:	45 Nm
Moment of inertia:	0.057 kg m ²
Motor efficiency at full load:	76.3 %
Motor efficiency at 3/4 load:	75.2 %
Motor efficiency at 1/2 load:	70.9 %
Number of poles:	4
Start. method:	direct-on-line
Enclosure class (IEC 34-5):	IP68
Insulation class (IEC 85):	F
Built-in motor protection:	THERMAL SWITCH
Thermal protec:	internal
Power cable type:	H07RN-F
Length of power cable:	10 m
Controls:	
Moisture sensor:	without moisture sensors
Water-in-oil sensor:	without water-in-oil sensor
Operation mode:	S1/S3 50%,1MIN.
Tank:	
Total effective volume of collecting tank at 180 mm inlet:	120 l
Total effective volume of collecting tank at 250 mm inlet:	240 l
Tank volume nominal:	450 l
Others:	
Net weight:	307 kg
Gross weight:	382 kg
Shipping volume:	2.27 m ³
Danish VVS No.:	154033222
Norwegian NRF no.:	9045376
Country of origin:	DE
Custom tariff no.:	84137021
Environmental approvals:	WEEE

On request MD1.80.80.22.4.50D /450.SE 50 Hz

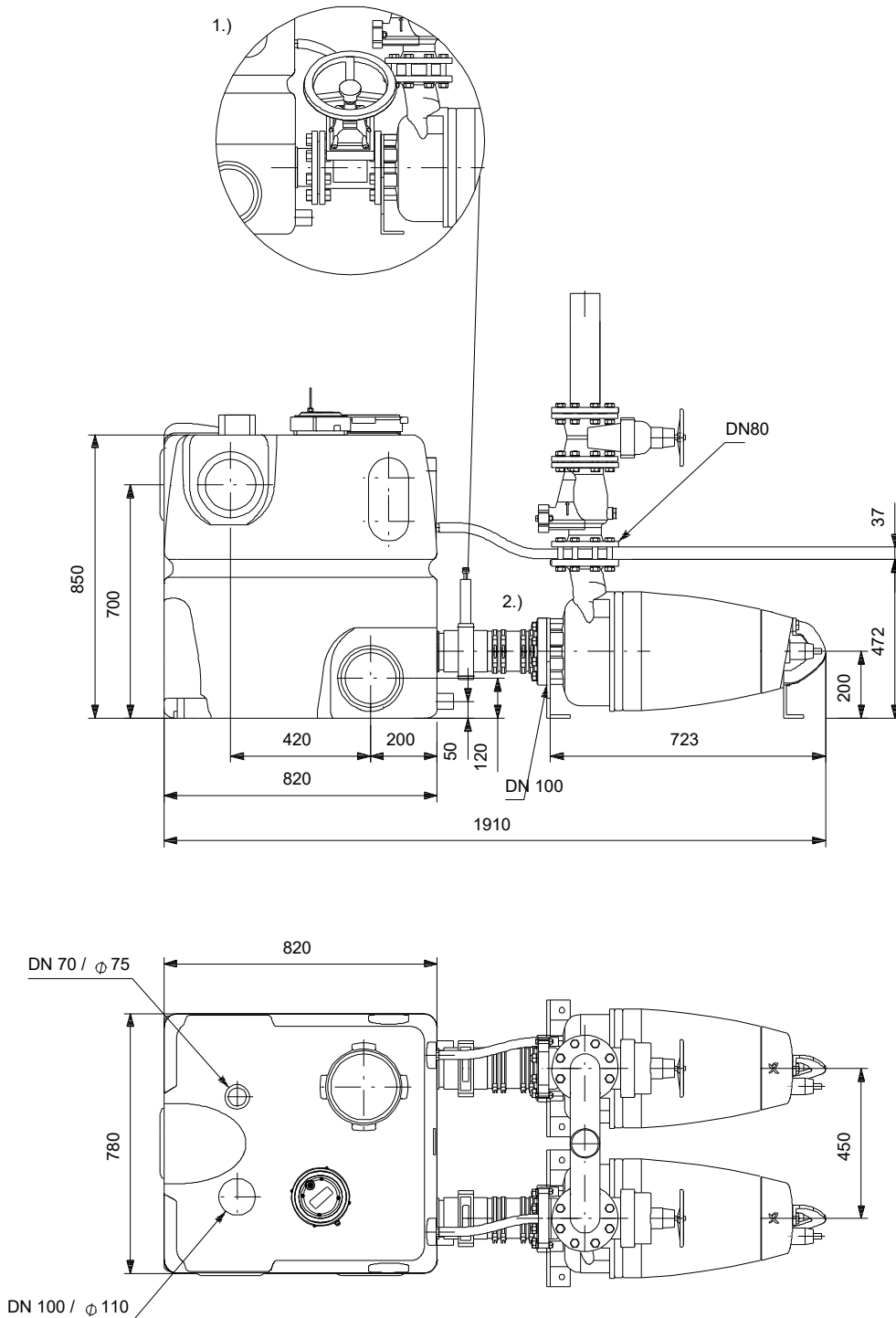

Note! All units are in [mm] unless others are stated.
Disclaimer: This simplified dimensional drawing does not show all details.

On request MD1.80.80.22.4.50D /450.SE 50 Hz

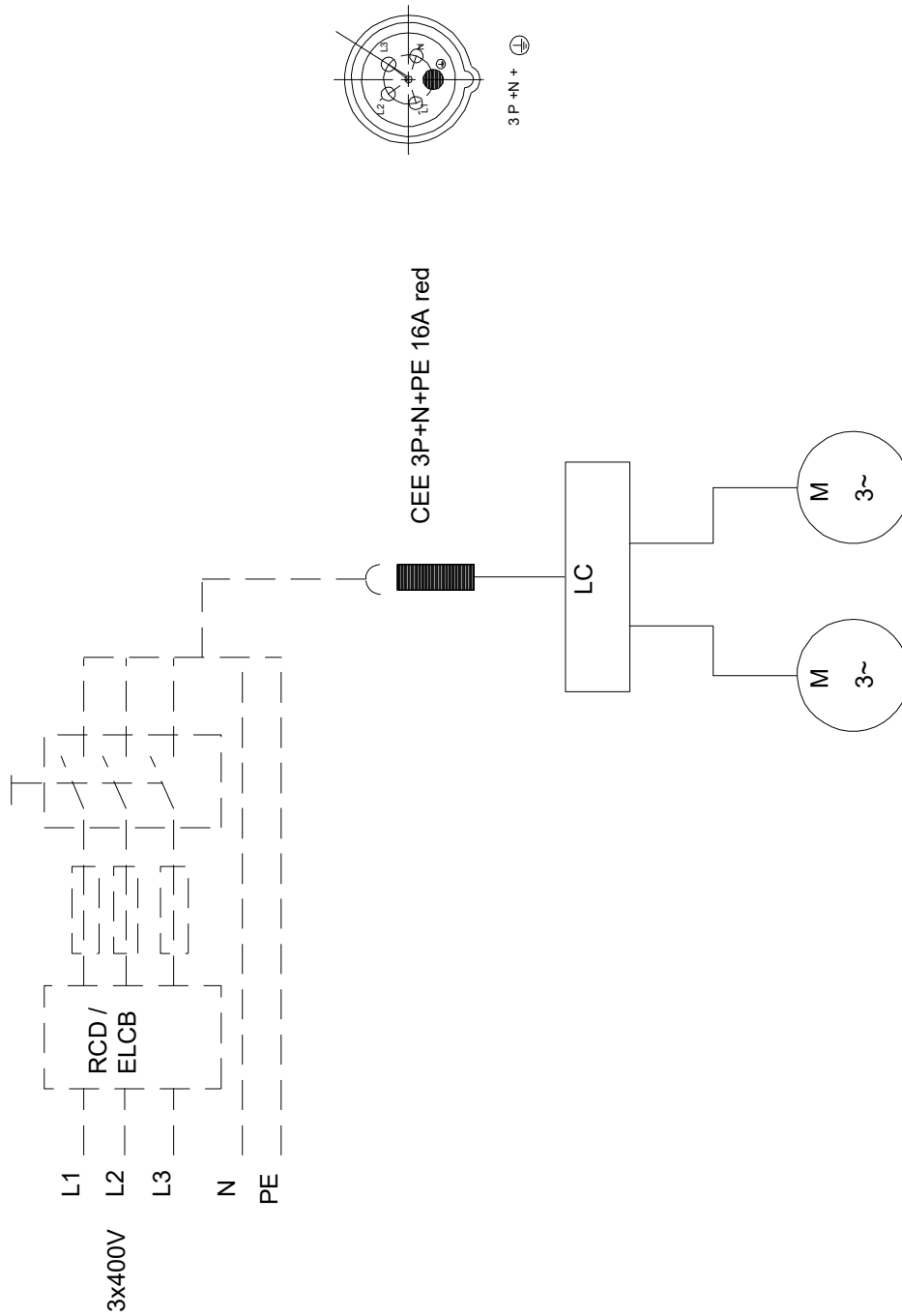

Note! All units are in [mm] unless others are stated.

