

Qty.	Description
------	-------------

1	Unilift CC7 - A1
---	-------------------------



Note! Product picture may differ from actual product

Product No.: On request

Grundfos Unilift CC pumps are single-stage submersible pumps with a low suction ability down to 3 mm water level.

The pumps are designed for pumping rainwater and grey wastewater, e.g. from

- washing machines, baths, sinks, etc. from low-lying parts of buildings up to sewer level
- cellars or buildings prone to flooding
- draining wells
- wells for surface water with inlets from roof gutters, pits, tunnels, etc.
- swimming pools, ponds or fountains.

The pumps are suitable for both stationary and portable use.

They are for automatic operation.

The pumps allow free passage of particles up to $\varnothing 10$ mm.

The motor incorporates automatic overload protection cutting out the motor in case of overload.

When cooled to normal temperature, the motor restarts automatically.

On request Unilift CC7 - A1 50 Hz

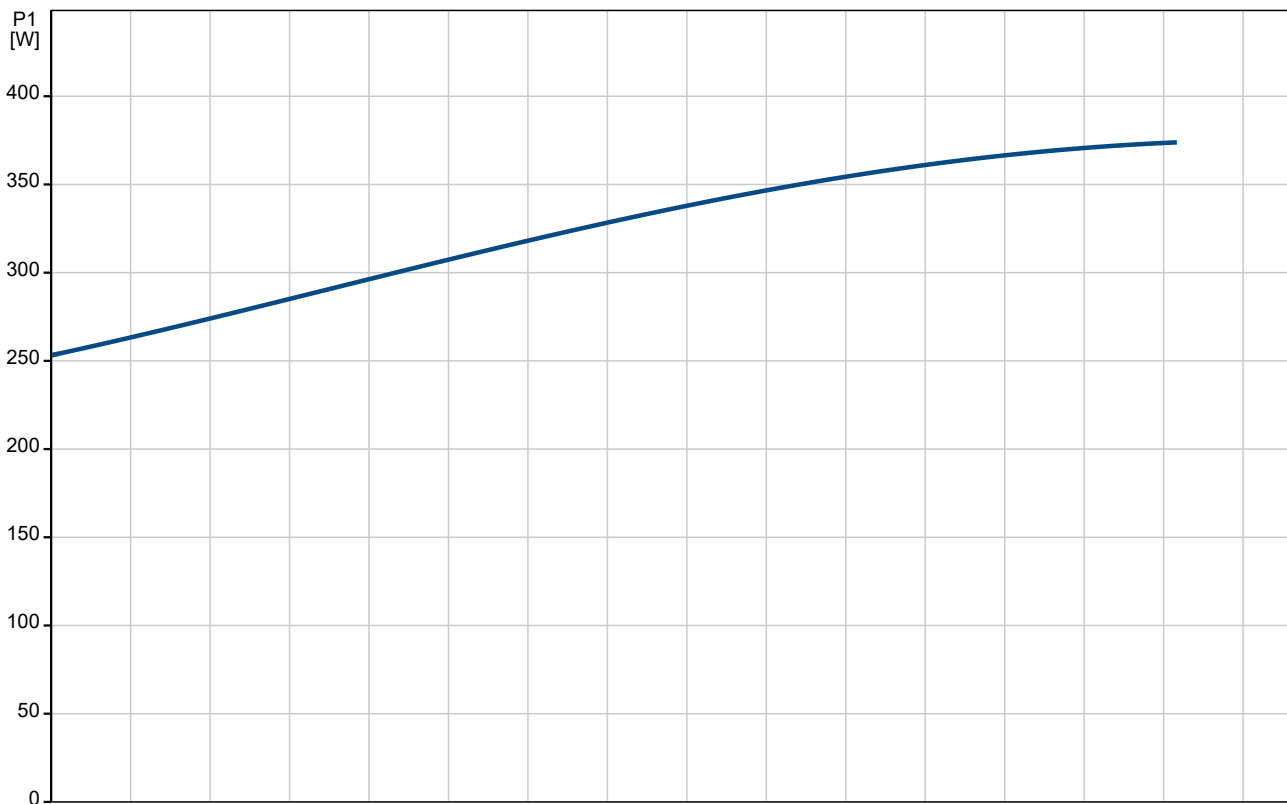
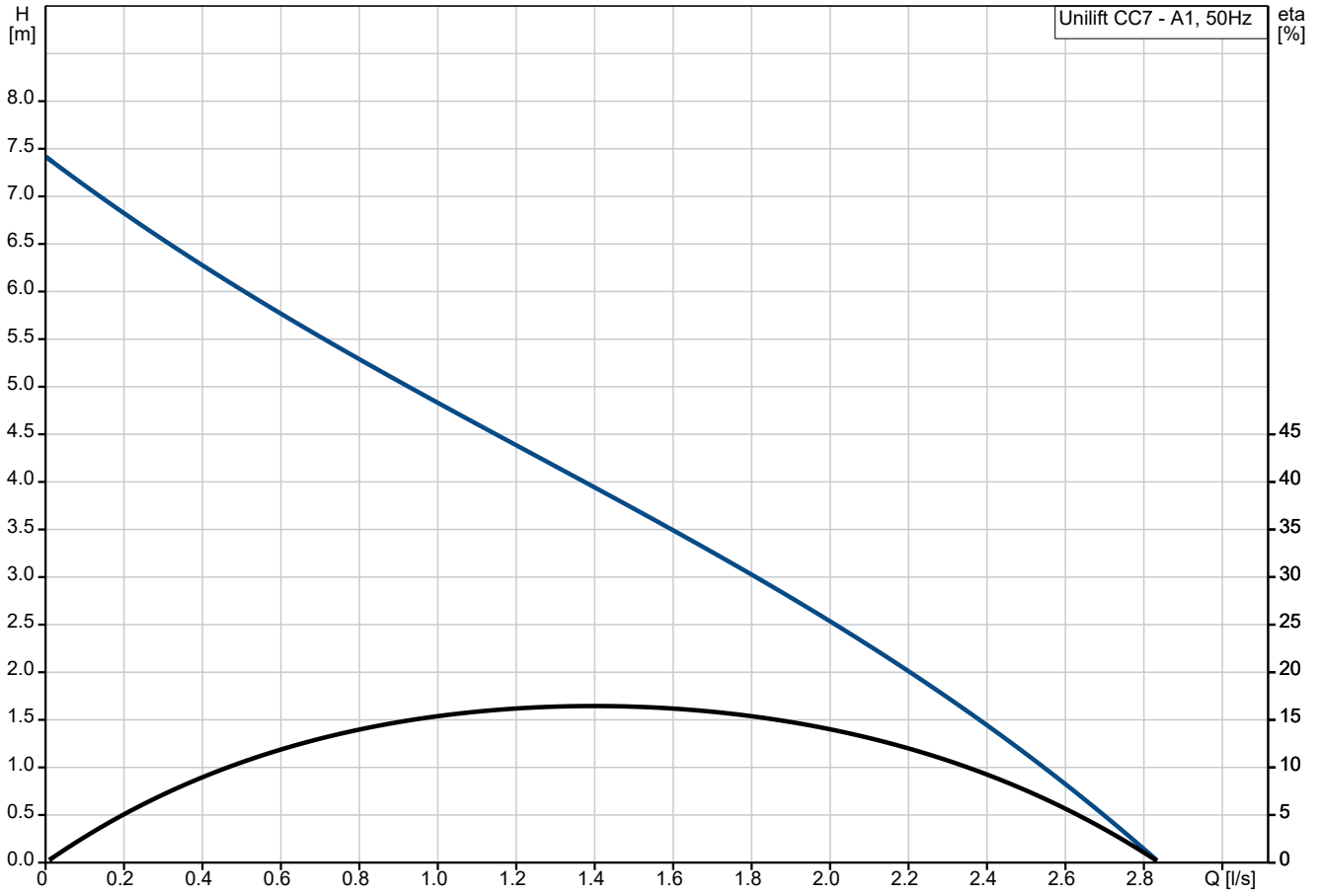

Description	Value
General information:	
Product name:	Unilift CC7 - A1
Product No:	On request
EAN number:	On request
Technical:	
Rated flow:	1.4 l/s
Maximum flow:	2.78 l/s
Rated head:	3.95 m
Maximum head:	7 m
Max. Particle:	10 mm
Approvals:	CE, LGA, VDE, UKCA, SEPRO
Materials:	
Pump housing:	Polypropylene
Pump housing:	PP - GF15
Impeller:	Composite
Impeller:	PP 20 GF
Motor:	Stainless steel
Motor:	EN 1.4301
Motor:	AISI 304
Shaft:	Stainless steel
Shaft:	EN 1.4301
Shaft:	AISI 304
Installation:	
Range of ambient temperature:	0 .. 40 °C
Type of connection:	R
Size of connection:	1 1/4 inch
Maximum installation depth:	7 m
Liquid:	
Liquid temperature range:	0 .. 40 °C
Density:	998.2 kg/m ³
Electrical data:	
Power input P1:	380 W
P2:	171 W
Mains frequency:	50 Hz
Rated voltage:	1 x 220-240 V
Rated current:	1.8 A
Rated speed:	2850 rpm
Capacitor size - run:	8 µF/450 V
Enclosure class (IEC 34-5):	IP68
Insulation class (IEC 85):	F
Built-in motor protection:	YES
Length of power cable:	10 m
Type of cable plug:	SCHUKO
Controls:	
Level switch:	float switch
Others:	
Net weight:	5.26 kg
Gross weight:	6.02 kg
Shipping volume:	0.017 m ³
Danish VVS No.:	391280371
Swedish RSK No.:	5885925
Norwegian NRF no.:	9045639
Country of origin:	HU
Custom tariff no.:	84137021
Environmental approvals:	WEEE

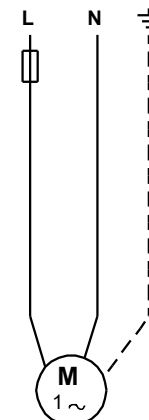
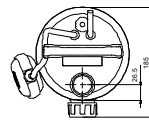
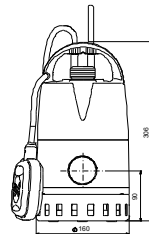
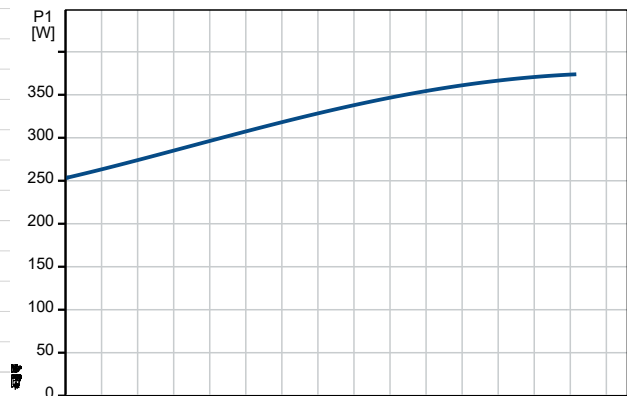
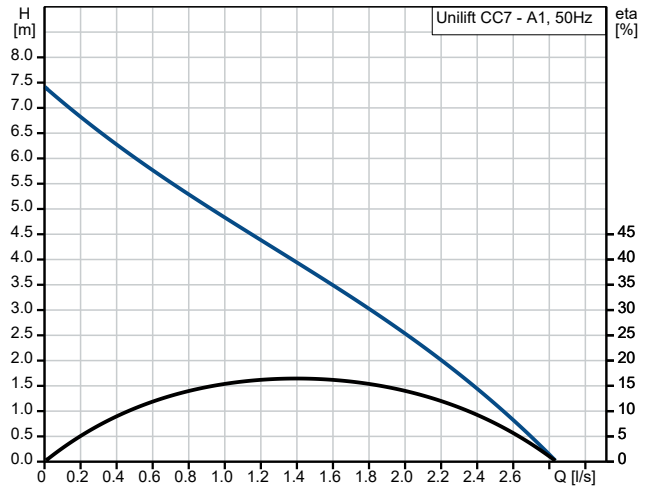

On request Unilift CC7 - A1 50 Hz

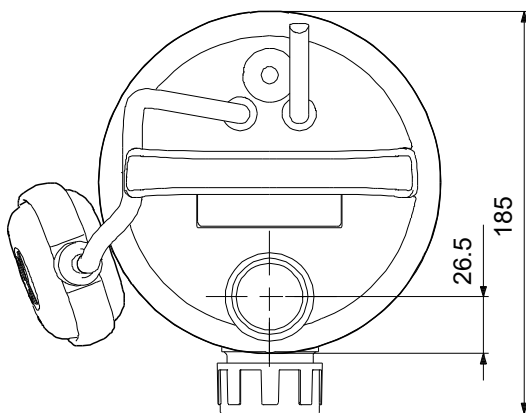
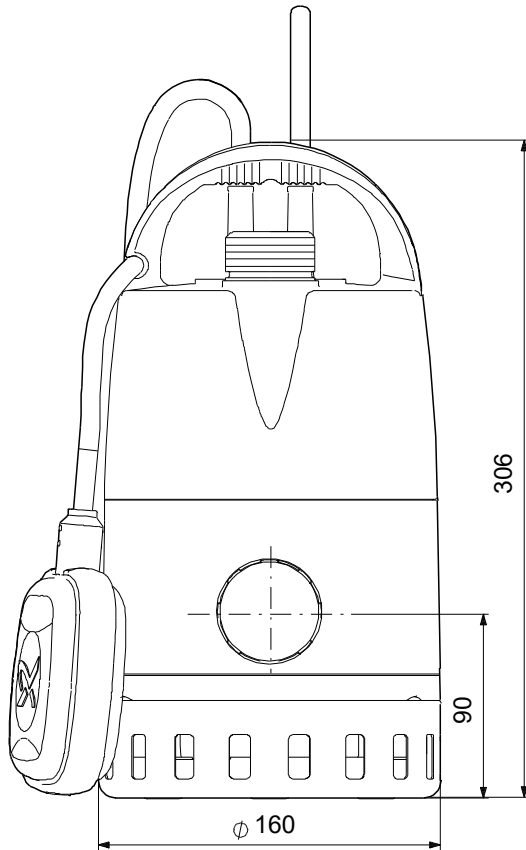

Note! All units are in [mm] unless others are stated.
Disclaimer: This simplified dimensional drawing does not show all details.

