

Qty. Description

1 UNILIFT AP50B.50.08.3V



Note! Product picture may differ from actual product

Product No.: On request
Submersible effluent pump

Vertical single-stage stainless steel submersible pump with integrated submersible 3-phase motor.

The pump is fitted with ring stand and carrying handle and is supplied with a 10 m mains cable.

The impeller is a VORTEX impeller for 50 mm free passage suitable for pumping surface water, groundwater, wastewater and similar.

The pump has a double shaft seal and an intermediate oil chamber pre-filled with non-toxic special oil.

The motor is insulation class F and has long-life deep-groove greased-for-life ball bearings.

The pump has Rp 2 inch discharge port and is ready for installation either free-standing or on an auto-coupling system.

On request UNILIFT AP50B.50.08.3V 50 Hz

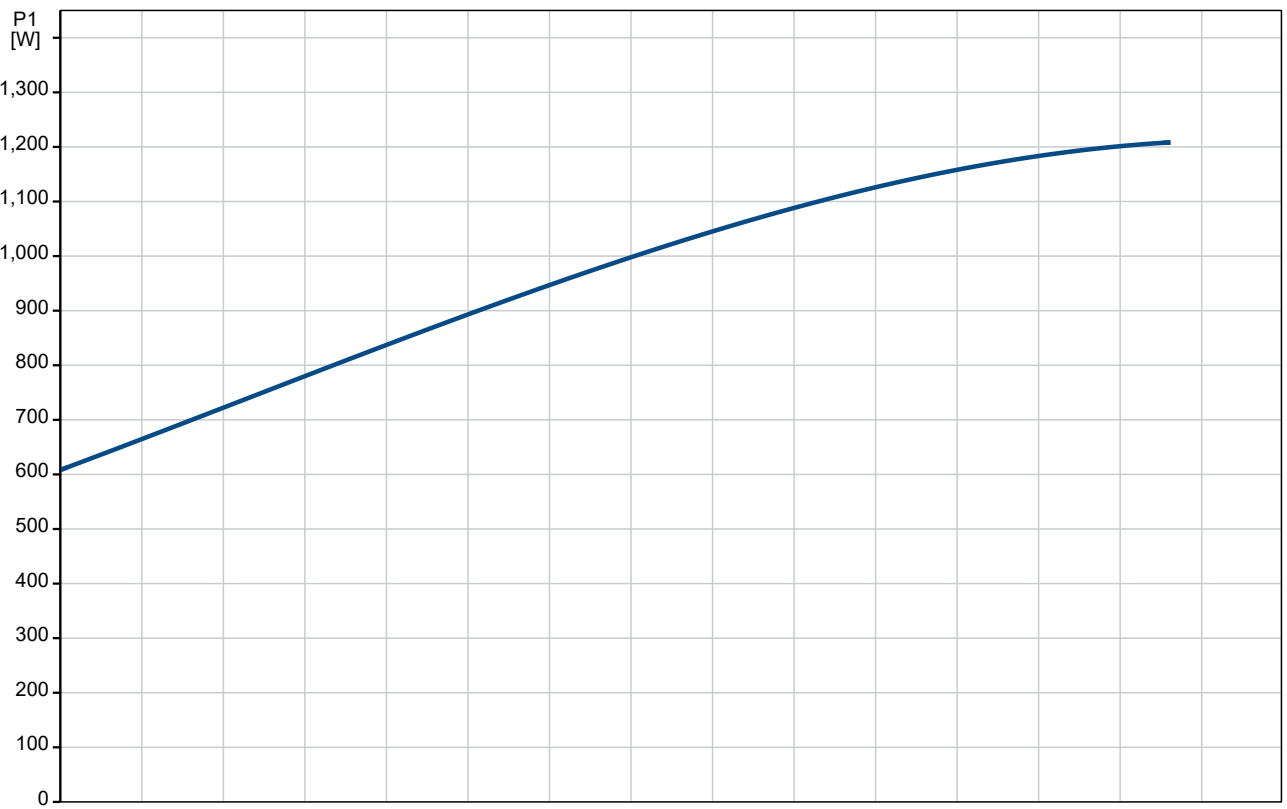
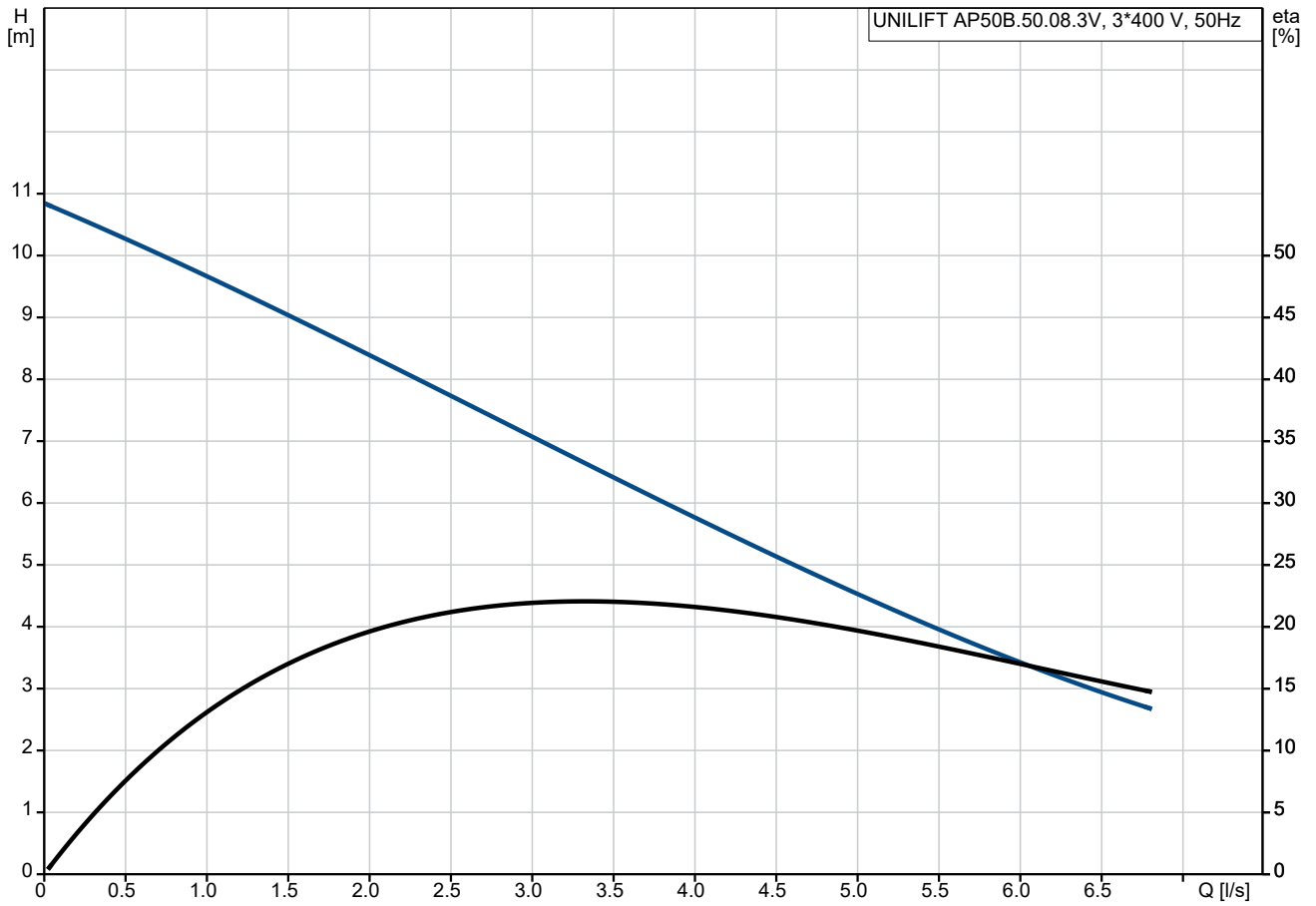

Description	Value
General information:	
Product name:	UNILIFT AP50B.50.08.3V
Product No:	On request
EAN number:	On request
Technical:	
Maximum flow:	6.67 l/s
Maximum head:	11 m
Type of impeller:	VORTEX
Max. Particle:	50 mm
Approvals:	CE,RCM,VDE,LGABG,EAC,MOR O,UKCA,CNROHSEXP,SEPRO
Materials:	
Pump housing:	Stainless steel
Pump housing:	EN 1.4301
Pump housing:	AISI 304
Impeller:	Stainless steel
Impeller:	EN 1.4301
Impeller:	AISI 304
Installation:	
Range of ambient temperature:	0 .. 40 °C
Type of connection:	Rp
Size of connection:	2 inch
Maximum installation depth:	7 m
Inst dry/wet:	S
Installation:	horizontal or vertical
Auto-coupling:	Y
Place of installation:	Indoor/outdoor
Liquid:	
Liquid temperature range:	0 .. 40 °C
Density:	998.2 kg/m ³
Electrical data:	
Power input P1:	1.25 kW
Rated power - P2:	0.8 kW
Mains frequency:	50 Hz
Rated voltage:	3 x 400 V
Rated current:	1.98 A
Cos phi - power factor:	0.89
Rated speed:	2810 rpm
Enclosure class (IEC 34-5):	IP68
Insulation class (IEC 85):	F
Built-in motor protection:	NONE
Thermal protec:	internal
Length of power cable:	10 m
Type of cable plug:	NONE
Others:	
Net weight:	10 kg
Gross weight:	11.4 kg
Danish VVS No.:	391273122
Swedish RSK No.:	5880139
Country of origin:	HU
Custom tariff no.:	84137021
Environmental approvals:	WEEE

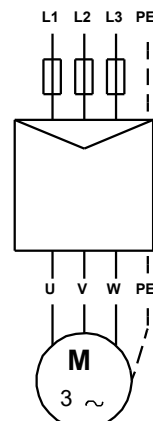
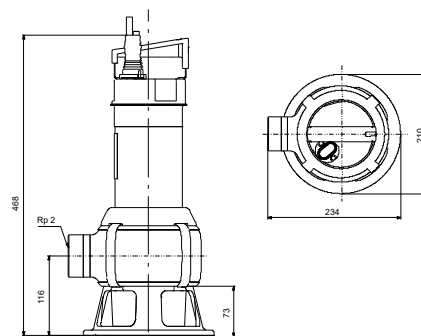
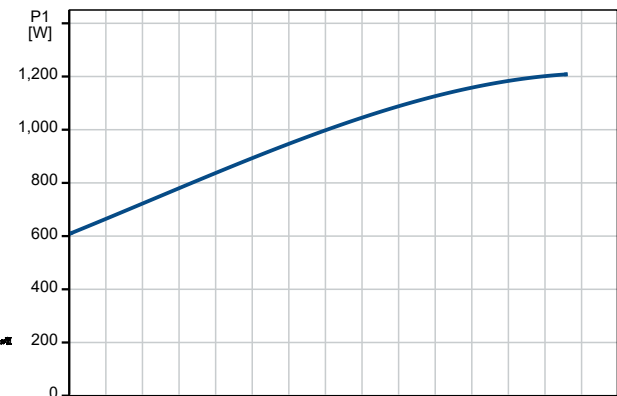
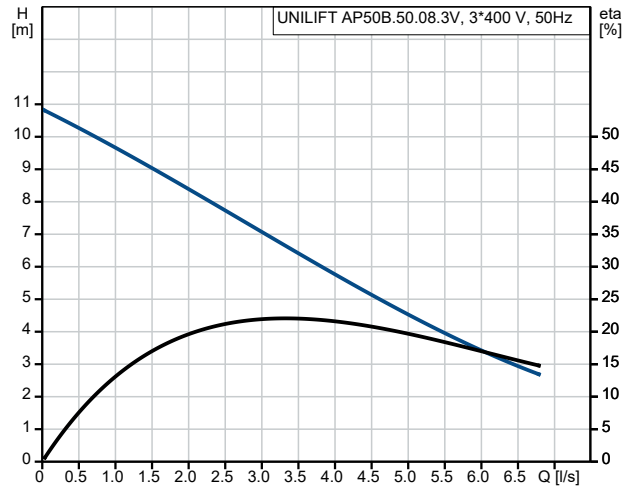

On request UNILIFT AP50B.50.08.3V 50 Hz

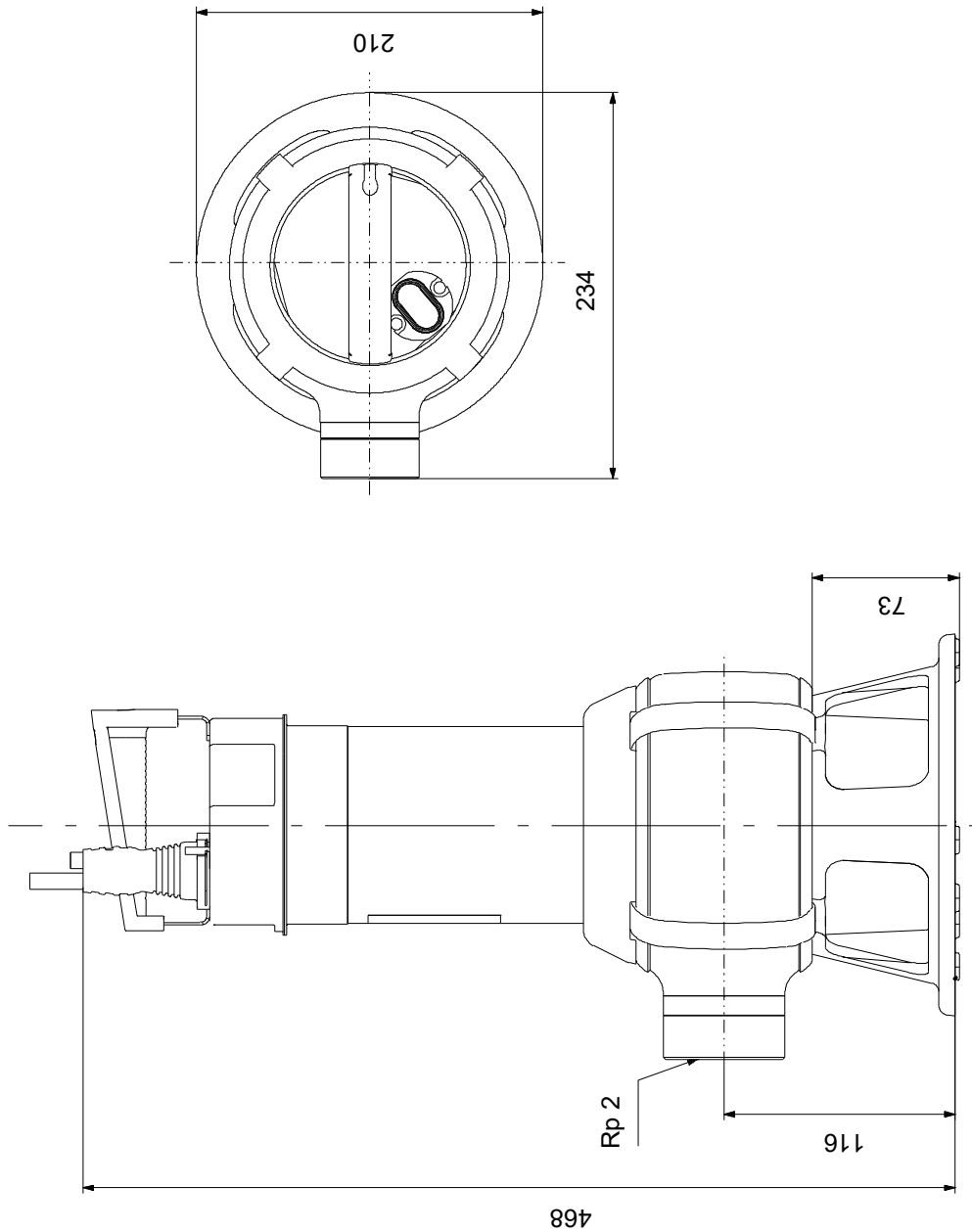

Note! All units are in [mm] unless others are stated.
Disclaimer: This simplified dimensional drawing does not show all details.

