

Submittal Data

PROJECT:	UNIT TAG:	QUANTITY:
REPRESENTATIVE: _____	TYPE OF SERVICE:	DATE: _____
ENGINEER:	SUBMITTED BY:	DATE:
CONTRACTOR:	APPROVED BY:	DATE:
	ORDER NO.:	DATE:



CME 3-3 A-R-I-E-AQQE

CME is a reliable, quite and compact horizontal end-suction pump with integrated frequency converter and intelligent features. The modular pump design makes it easy to make customised solutions.

Note! Product picture may differ from actual product

Conditions of Service		Pump Data		Motor Data	
Liquid:	Water	Max pressure at stated temp:	10 bar / 120 °C	Mains frequency:	50 Hz
Temperature:	20 °C	Liquid temperature range:	-20 .. 120 °C	Enclosure class:	IP55
Specific Gravity:	1.000	Maximum ambient temperature:	40 °C		
		Shaft seal:	AQQE		
		Product number:	On request		

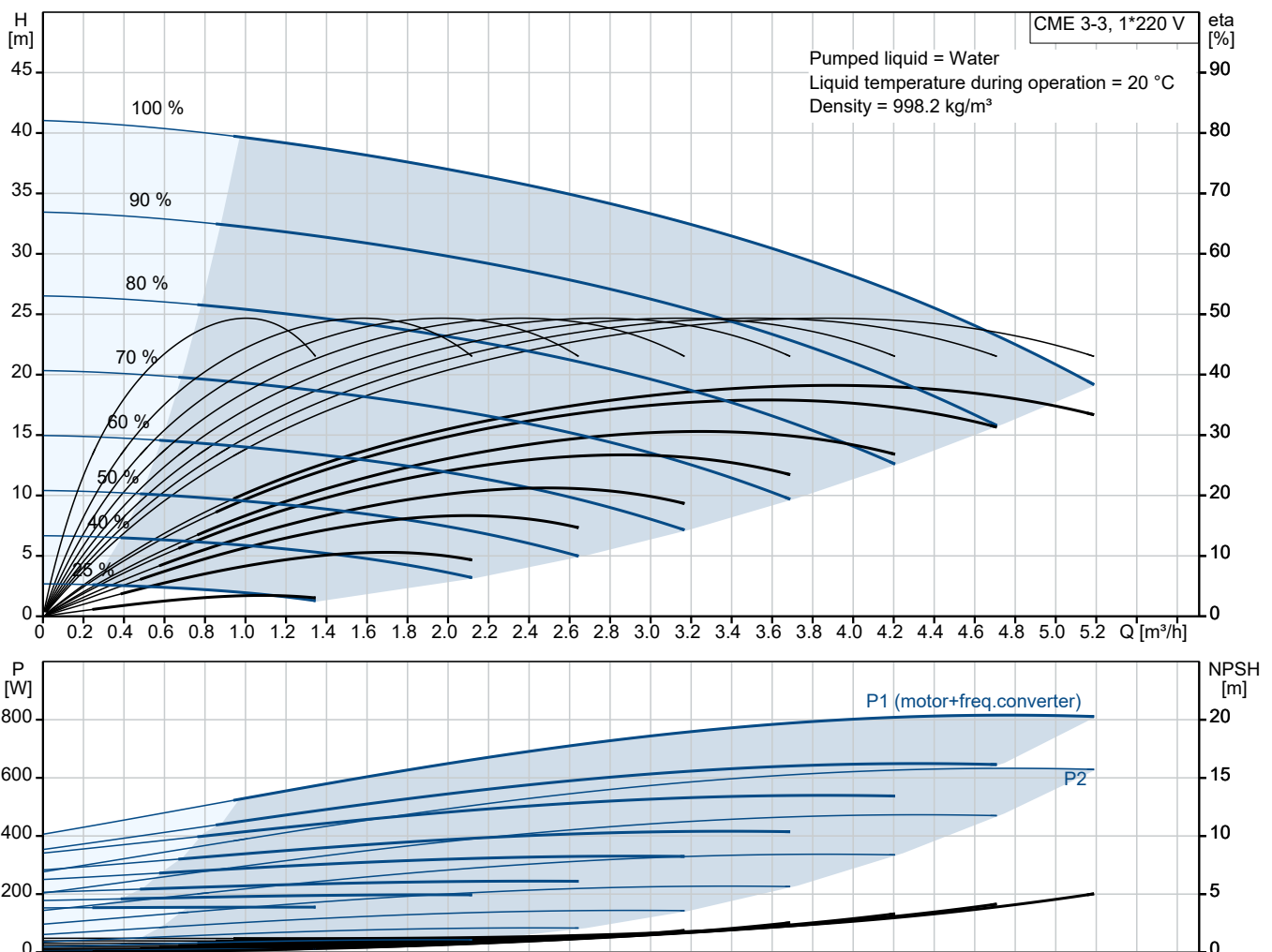

Submittal Data

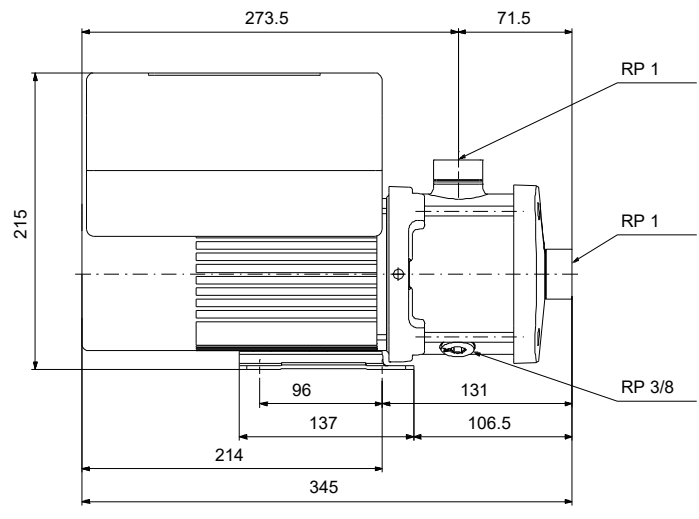
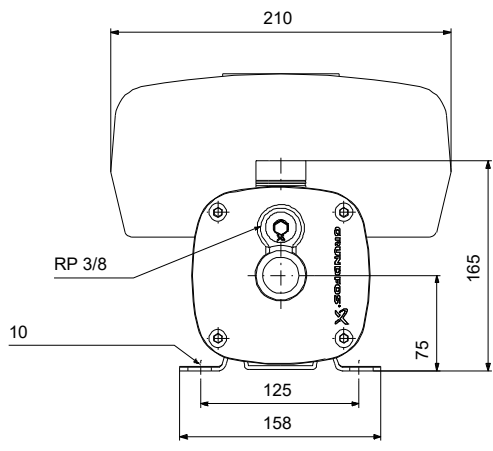

Materials:

- Pump housing: Stainless steel
- Pump housing: AISI 304
- Impeller: Stainless steel
- Impeller: 304
- Impeller: 1.4301
- Material code: I
- Code for rubber: E

Qty. Description

1 CME 3-3 A-R-I-E-AQQE



Product No.: On request

Compact, reliable, horizontal, multistage, end-suction centrifugal pump with axial suction port and radial discharge port. The mechanical shaft seal is a special designed, unbalanced O-ring seal. Pipework connection is via internal Whitworth pipe threads, Rp (ISO 7/1).

The pump is fitted with a 1-phase, foot-mounted, fan-cooled asynchronous motor.

The motor includes a frequency converter and PI controller in the motor terminal box. This enables continuously variable control of the motor speed, which again enables adaptation of the performance to a given requirement.

An operating panel on the motor terminal box enables setting of required setpoint as well as setting of pump to "Min." or "Max." operation or to "Stop". The operating panel has indicator lights for "Operation" and "Fault".

Communication with the pump is possible by means of Grundfos GO Remote (accessory). The remote control enables further settings as well as reading out of a number of parameters such as "Actual value", "Speed", "Power input" and total "Power consumption".

The terminal box holds terminals for these connections:

- pump start/stop input (potential-free contact)
- remote setpoint setting via analog signal, 0-10 V, 0(4)-20 mA
- 10 V voltage supply for setpoint potentiometer, I_{max} = 5 mA
- one analog sensor input, 0-10 V, 0(4)-20 mA
- 24 V voltage supply for sensor, I_{max} = 40 mA
- one digital input
- one potential-free fault signal relay with changeover contact, reporting "Fault", "Operation" or "Ready"
- RS-485 GENIbus connection.

Further product details

Pump and motor are integrated in a compact and user-friendly design. The pump is fitted to a low base plate, making it ideal for installation in systems where compactness is important.

The state-of-the-art design and materials of the shaft seal ensure high wear resistance, improved sticking and dry-running capabilities and long operating life.

Servicing the pump requires no special service tools. Service parts are in stock for quick delivery and are available as kits, single parts or bulk. Service videos are available on www.youtube.com.

Frequency converter operation offers these functions:

- controlled operation, i.e. consumption fluctuates
- constant pressure
- communication with the pump.

Adaption of performance through frequency-controlled speed offers obvious benefits such as:

- energy savings
- increased comfort
- control and monitoring of the application and pump performance.

An operating panel on the motor terminal box enables setting of required setpoint as well as setting of pump to "Min." or "Max." operation or to "Stop". The operating panel has indicator lights for "Operation" and "Fault".

Communication with the pump is possible by means of Grundfos GO Remote (accessory). The remote control enables further settings as well as reading out of a number of parameters such as "Actual value", "Speed", "Power input" and total "Power consumption".

Pump

Qty. Description

1 A combination of a stop ring and a Nord-lock® washer secures a tight and reliable fixation of the impeller spacing pipes to the splined pump shaft. It is possible to remove and fit the hydraulic parts from the pump side. The inlet and outlet port are integrated in the pump sleeve. The inlet part, chambers and discharge part are hold together by four staybolts and a retaining flange.

The pump is fitted with an unbalanced O-ring seal with a rigid torque-transmission system. It has a fixed seal driver ensuring a reliable rotation of all parts. The dynamic secondary seal is an O-ring.

Seal faces:

- Rotating seal ring material: silicon carbide (SiC)
- Stationary seat material: silicon carbide (SiC)

This material pairing is used where higher corrosion resistance is required. The high hardness of this material pairing offers good resistance against abrasive particles.

Secondary seal material: EPDM (ethylene-propylene rubber)

EPDM has excellent resistance to hot water. EPDM is not suitable for mineral oils.



The pump shaft is connected to the motor shaft through a left thread and tight fit. The shaft cannot be dismantled.

Motor

The motor is a totally enclosed, fan-cooled motor with principal dimensions to EN 50347. Electrical tolerances comply with EN 60034.

The motor requires no external motor protection. The motor control unit incorporates protection against slow- and quick-rising temperatures, e.g. constant overload and stalled conditions.

The terminal box holds terminals for these connections:

- pump start/stop input (potential-free contact)
- remote setpoint setting via analog signal, 0-10 V, 0(4)-20 mA
- 10 V voltage supply for setpoint potentiometer, I_{max} = 5 mA
- one analog sensor input, 0-10 V, 0(4)-20 mA
- 24 V voltage supply for sensor, I_{max} = 40 mA
- one digital input
- one potential-free fault signal relay with changeover contact, reporting "Fault", "Operation" or "Ready"
- RS-485 GENIbus connection.

Technical data

Controls:

Frequency converter: Built-in

Liquid:

Pumped liquid: Water

Liquid temperature range: -20 .. 120 °C

Selected liquid temperature: 20 °C

Density: 998.2 kg/m³

Technical:

Pump speed on which pump data are based: 3480 rpm

Rated flow: 3.7 m³/h

Rated head: 29.3 m

Code for shaft seal: AQQE

Approvals: CE,TR,EAC

Approvals for drinking water: WRAS,ACS

Curve tolerance: ISO9906:2012 3B

On request CME 3-3 A-R-I-E-AQQE 50 Hz

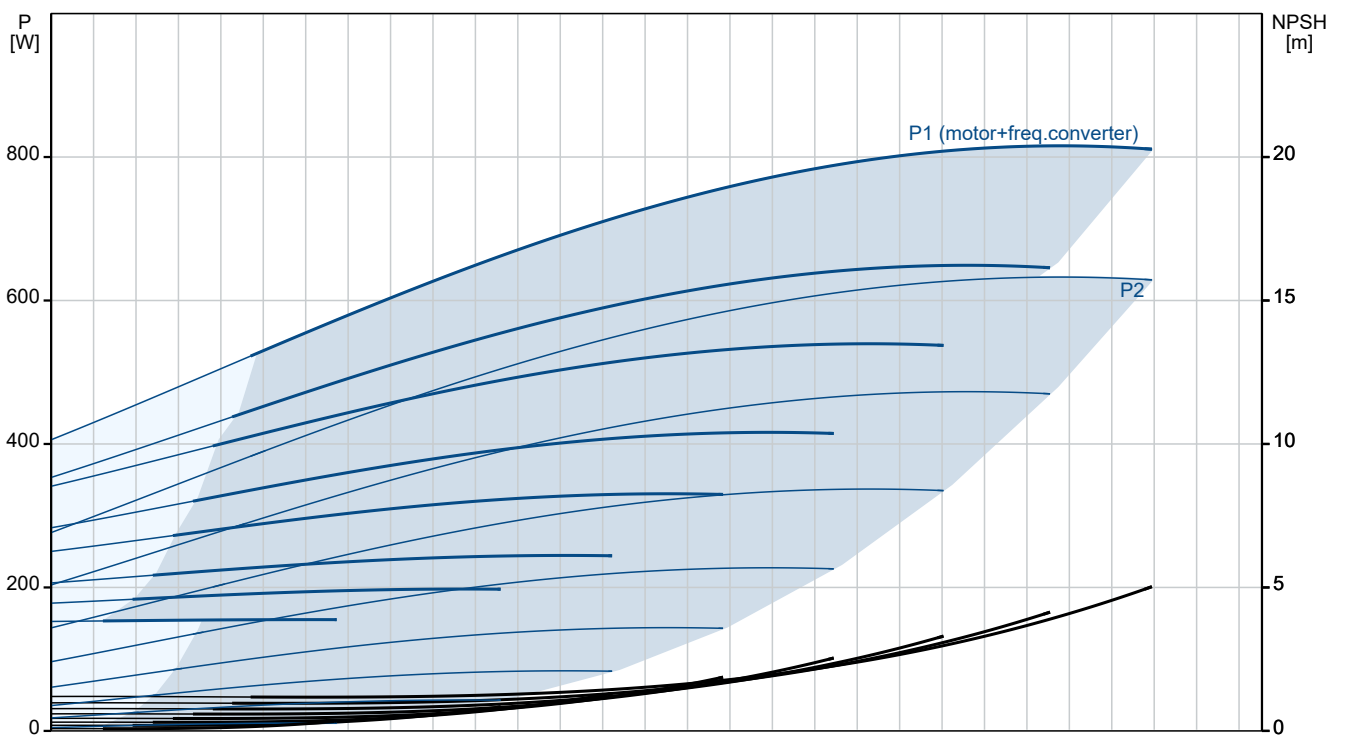
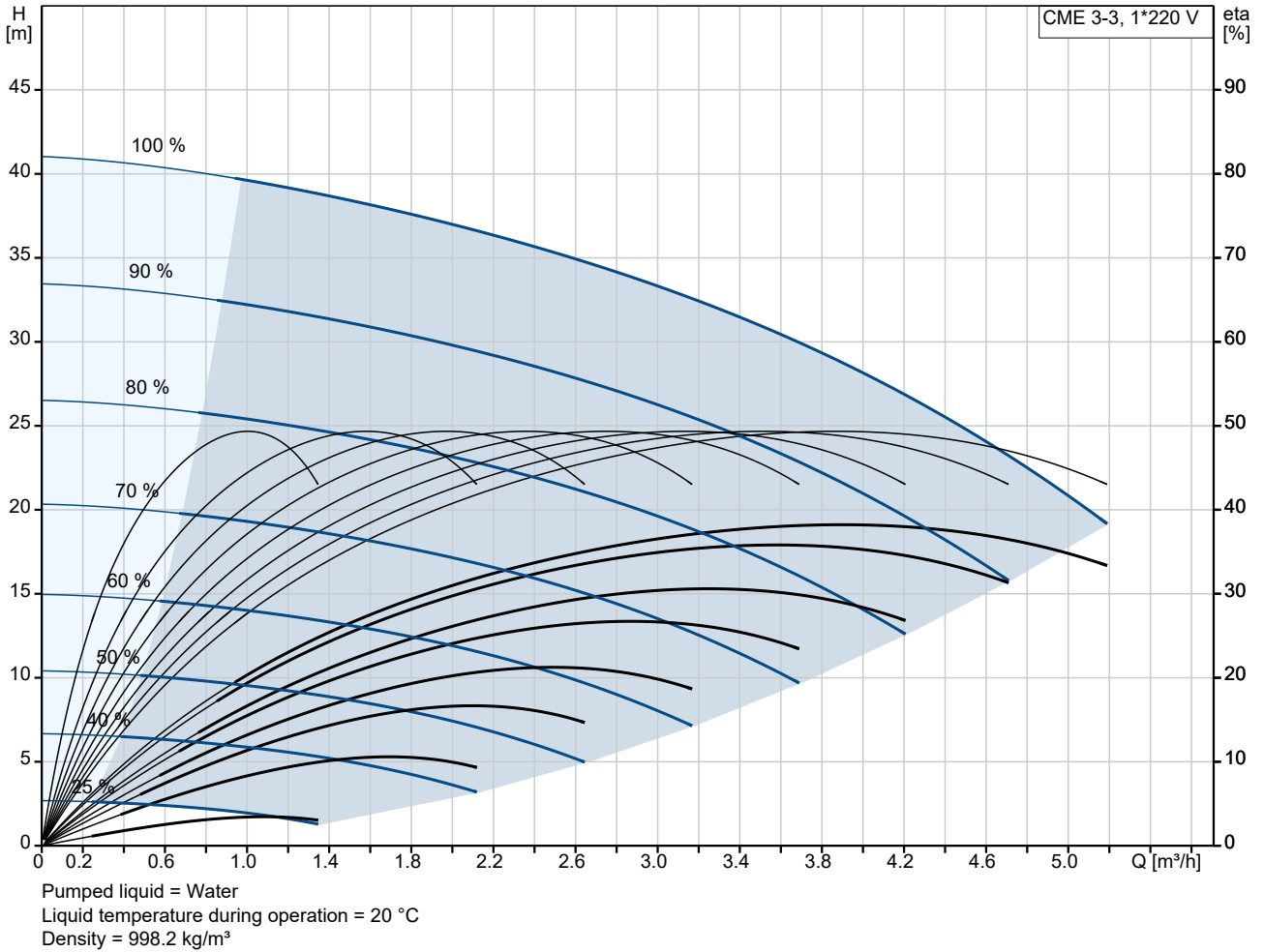

Description	Value
General information:	
Product name:	CME 3-3 A-R-I-E-AQQE
Product No:	On request
EAN number:	On request
Technical:	
Pump speed on which pump data are based:	3480 rpm
Rated flow:	3.7 m ³ /h
Rated head:	29.3 m
Impellers:	3
Code for shaft seal:	AQQE
Approvals:	CE,TR,EAC
Approvals for drinking water:	WRAS,ACS
Curve tolerance:	ISO9906:2012 3B
Pump version:	A
Model:	A
Materials:	
Pump housing:	Stainless steel
Pump housing:	EN 1.4301
Pump housing:	AISI 304
Impeller:	Stainless steel
Impeller:	1.4301
Impeller:	304
Material code:	I
Code for rubber:	E
Installation:	
Maximum ambient temperature:	40 °C
Maximum operating pressure:	16 bar
Max pressure at stated temp:	10 bar / 120 °C
Max pressure at stated temp:	16 bar / 90 °C
Type of connection:	Rp
Size of inlet connection:	1 inch
Size of outlet connection:	1 inch
Outlet position:	12
Connect code:	R
Liquid:	
Pumped liquid:	Water
Liquid temperature range:	-20 .. 120 °C
Selected liquid temperature:	20 °C
Density:	998.2 kg/m ³
Electrical data:	
Frame size:	80B
IE efficiency class:	0
Rated power - P2:	1.1 kW
Mains frequency:	50 Hz
Suitable for 50/60 Hz:	YES
Rated voltage:	1 x 200-240 V
Rated current:	8.20-6.80 A
Rated speed:	430-3400 rpm
Enclosure class (IEC 34-5):	IP55
Insulation class (IEC 85):	F
Controls:	
Frequency converter:	Built-in
Others:	
Terminal box position:	12
Minimum efficiency index, MEI ≥:	0.7
Net weight:	17.5 kg

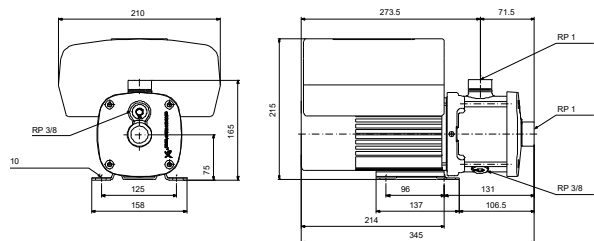
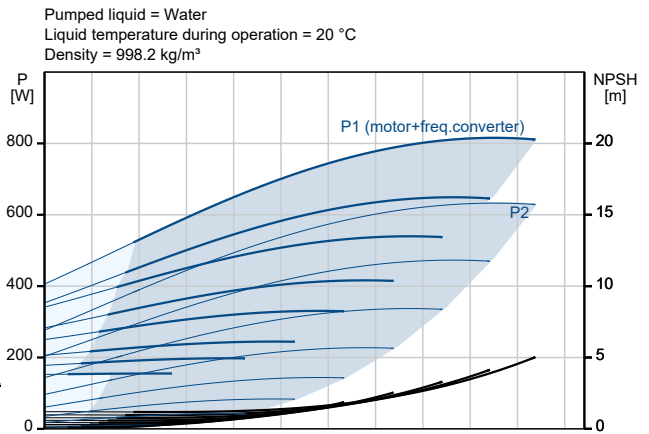
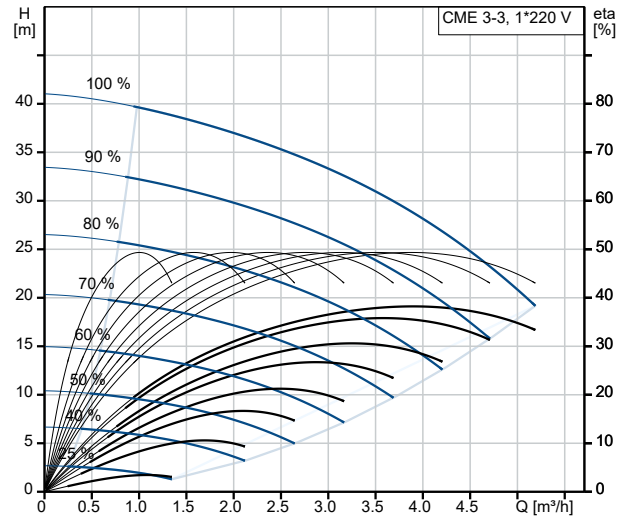



Company name:

Created by:

Phone:

Date:

24/01/2024

Description	Value
Gross weight:	21 kg

On request CME 3-3 A-R-I-E-AQQE 50 Hz

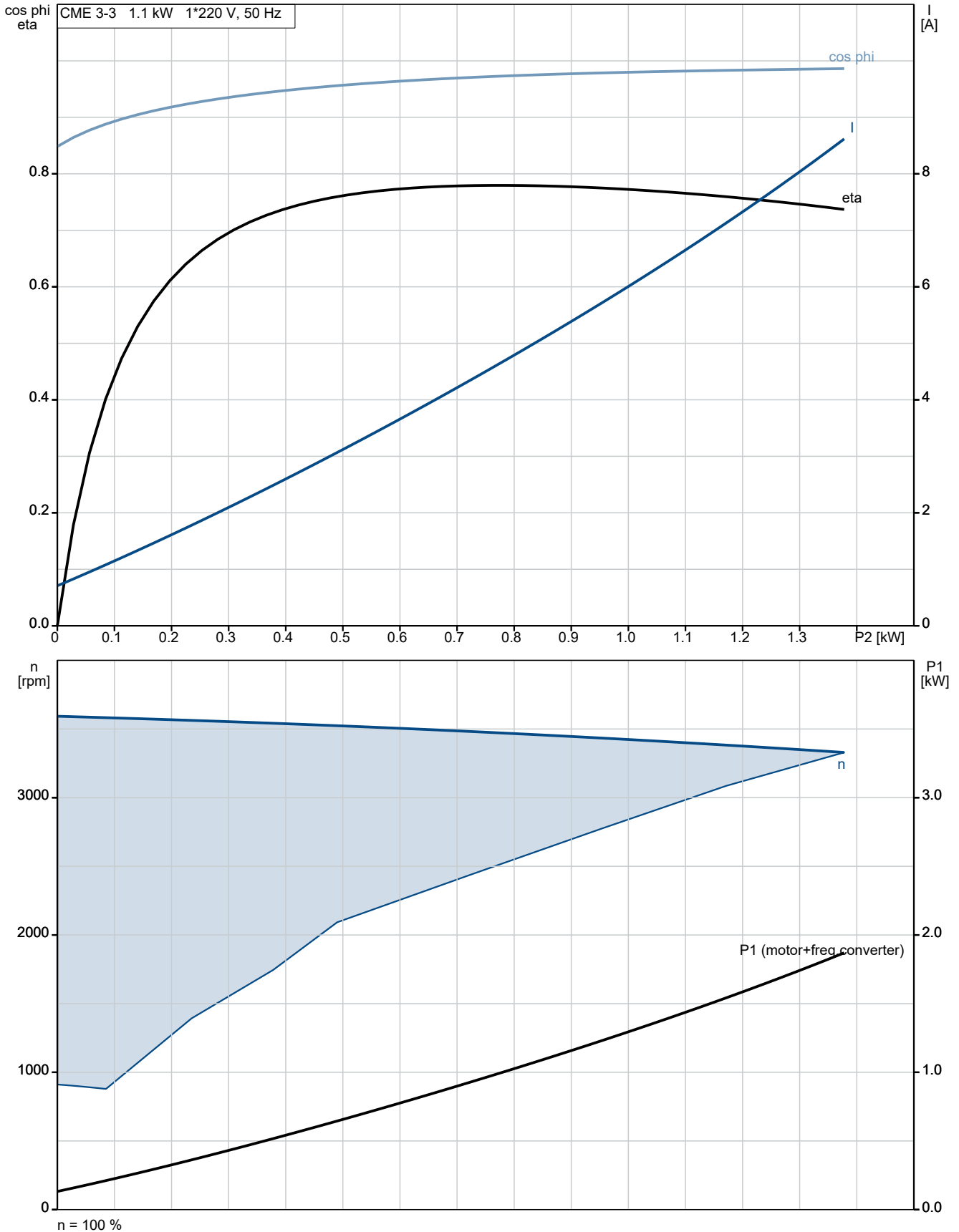

On request CME 3-3 A-R-I-E-AQQE 50 Hz

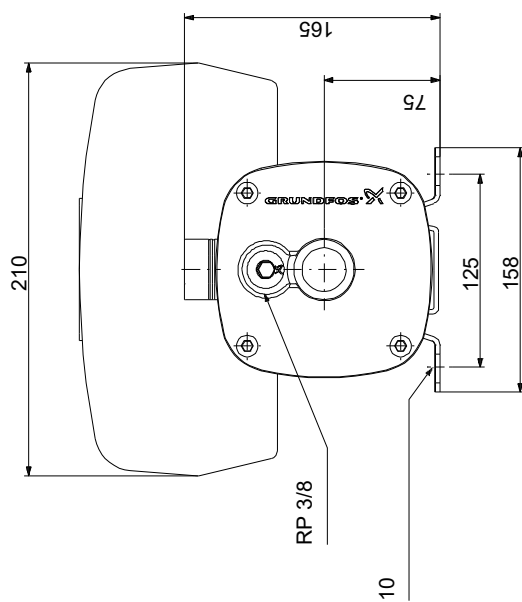
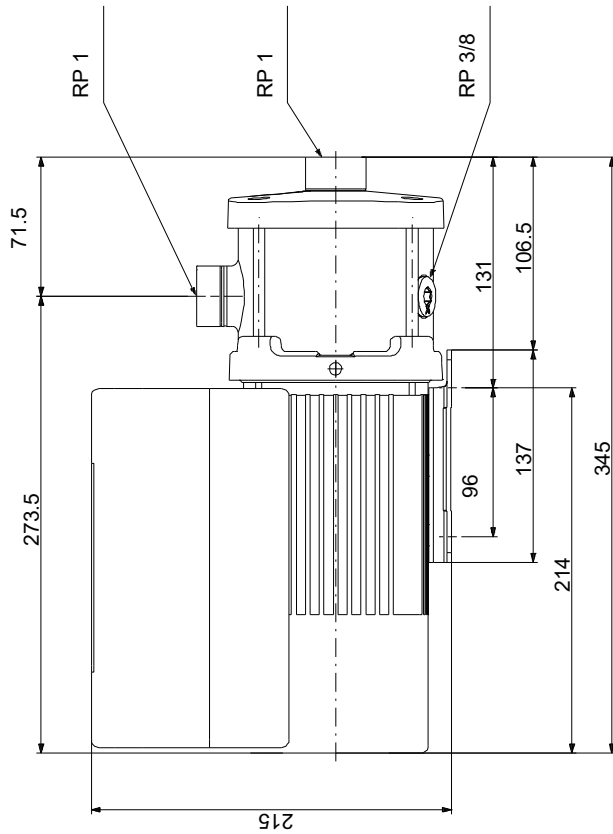

Note! All units are in [mm] unless others are stated.
Disclaimer: This simplified dimensional drawing does not show all details.

