

Qty. Description

1 MULTIBOX UNILIFT CC7-A1



Note! Product picture may differ from actual product

Product No.: On request

MULTIBOX UNILIFT CC7 A1 is a solution recommended for cellars and buildings prone to flooding.

MULTIBOX UNILIFT CC7 A1 contains:

- UNILIFT CC7 A1 pump
- strainer/transportation box with lid
- Storz C coupling
- 15 m hose
- anti-kink sleeve
- non-return valve.

The UNILIFT CC7 A1 pump is a single-stage, highly robust submersible pump capable of pumping down to a 3 mm water level and handling particles up to 10 mm.

The pump body contains a cooling jacket for operating partly submerged.

The pump has both a top and a side outlet, allowing easy adaptation to existing pipes including auto-coupling systems.



Company name:

Created by:

Phone:

Date:

29/11/2023

On request MULTIBOX UNILIFT CC7-A1 50 Hz

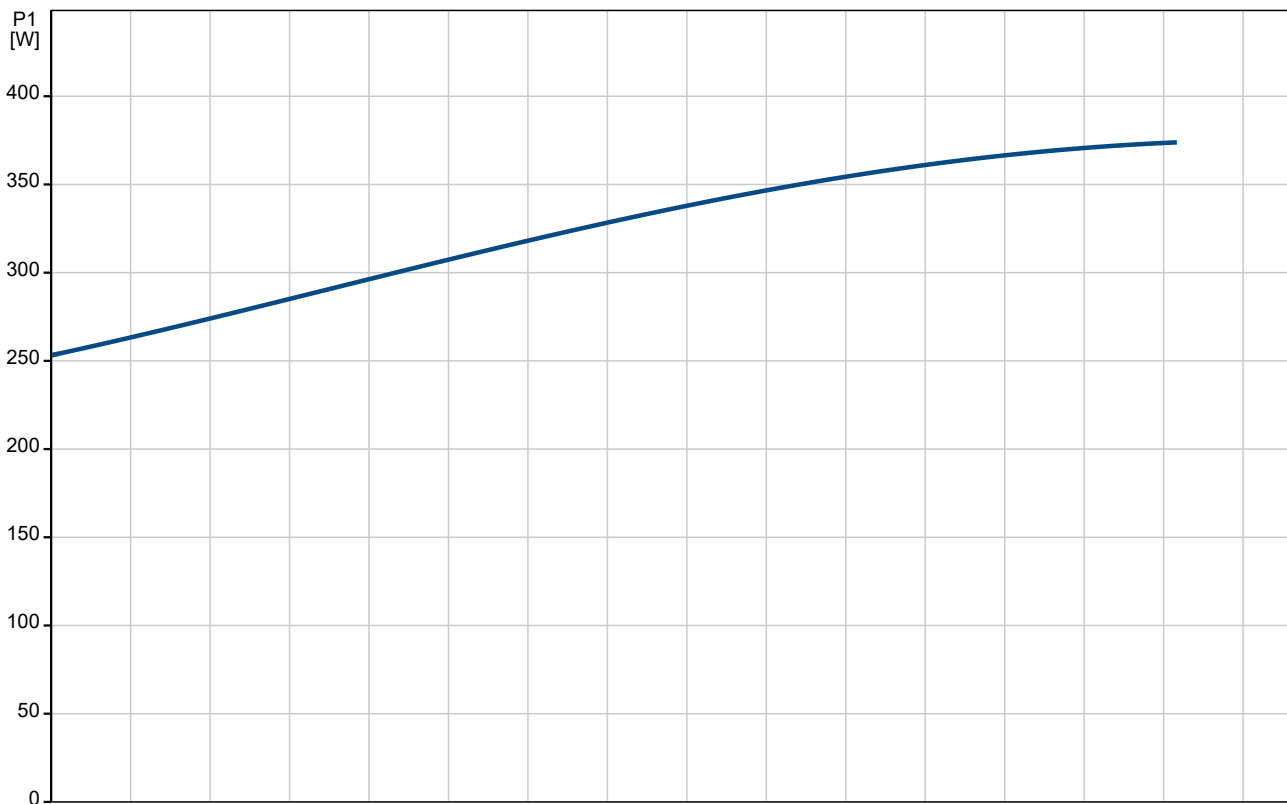
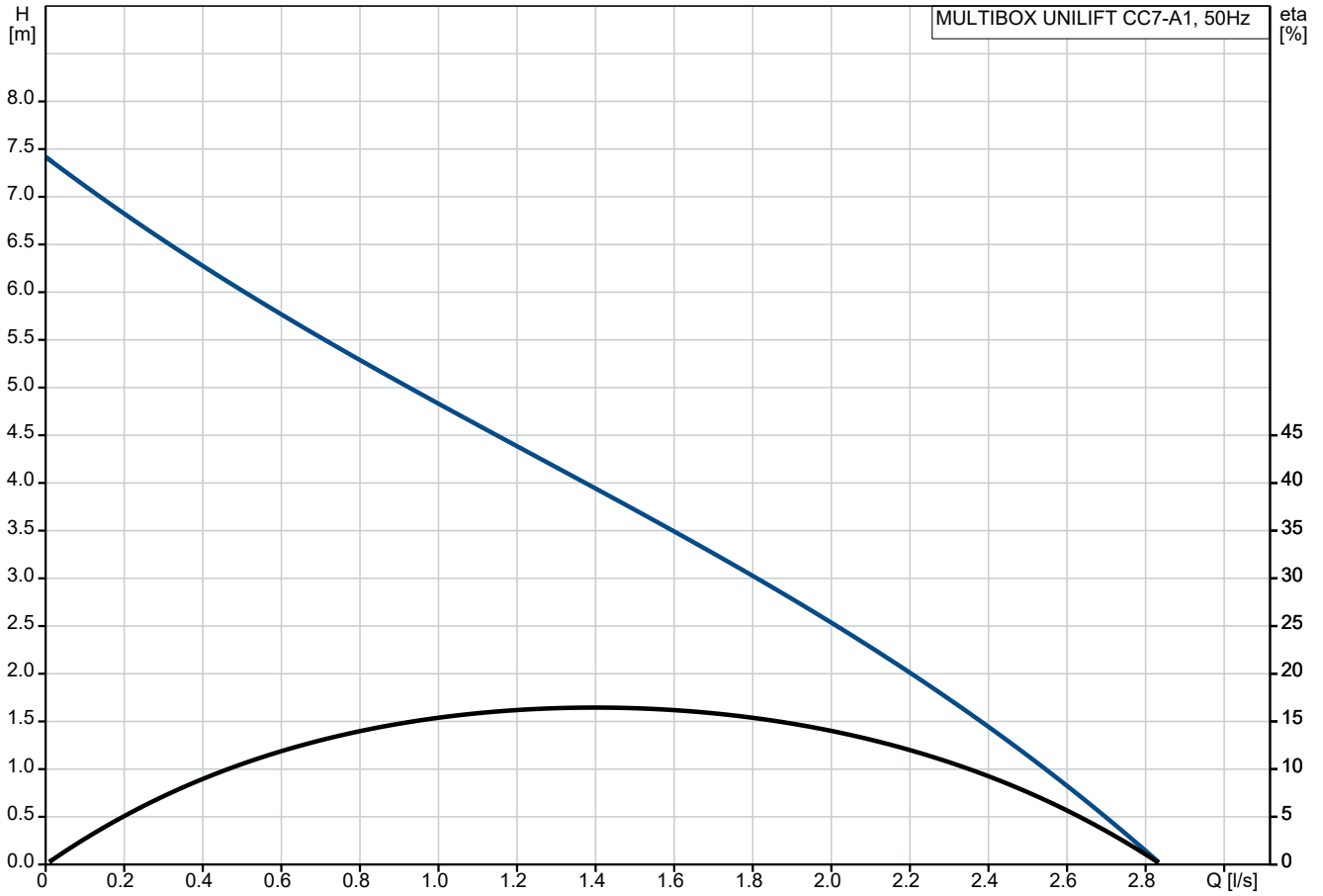

| Description | Value |
|-------------------------------|-------------------------|
| General information: | |
| Product name: | MULTIBOX UNILIFT CC7-A1 |
| Product No: | On request |
| EAN number: | On request |
| Technical: | |
| Rated flow: | 1.4 l/s |
| Maximum flow: | 2.78 l/s |
| Rated head: | 3.95 m |
| Maximum head: | 7 m |
| Max. Particle: | 10 mm |
| Approvals: | CE,LGA,VDE,UKCA,SEPRO |
| Materials: | |
| Pump housing: | Polypropylene |
| Pump housing: | PP - GF15 |
| Impeller: | Composite |
| Impeller: | PP 20 GF |
| Motor: | Stainless steel |
| Motor: | EN 1.4301 |
| Motor: | AISI 304 |
| Shaft: | Stainless steel |
| Shaft: | EN 1.4301 |
| Shaft: | AISI 304 |
| Installation: | |
| Range of ambient temperature: | 0 .. 40 °C |
| Type of connection: | R |
| Size of connection: | 1 1/4 inch |
| Maximum installation depth: | 7 m |
| Liquid: | |
| Liquid temperature range: | 0 .. 40 °C |
| Density: | 998.2 kg/m ³ |
| Electrical data: | |
| Power input P1: | 380 W |
| P2: | 171 W |
| Mains frequency: | 50 Hz |
| Rated voltage: | 1 x 220-240 V |
| Rated current: | 1.8 A |
| Rated speed: | 2850 rpm |
| Capacitor size - run: | 8 µF/450 V |
| Enclosure class (IEC 34-5): | IP68 |
| Insulation class (IEC 85): | F |
| Built-in motor protection: | YES |
| Length of power cable: | 10 m |
| Type of cable plug: | SCHUKO |
| Controls: | |
| Level switch: | float switch |
| Others: | |
| Net weight: | 12 kg |
| Gross weight: | 12.2 kg |
| Shipping volume: | 0.038 m ³ |
| Danish VVS No.: | 391281307 |
| Swedish RSK No.: | 5885967 |
| Finnish LVI No.: | 4762517 |
| Norwegian NRF no.: | 9040795 |
| Country of origin: | HU |
| Custom tariff no.: | 84137021 |
| Environmental approvals: | WEEE |

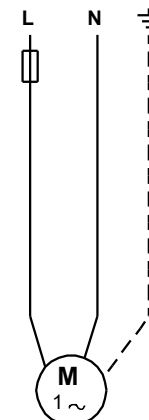
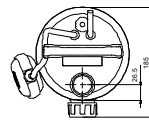
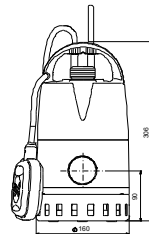
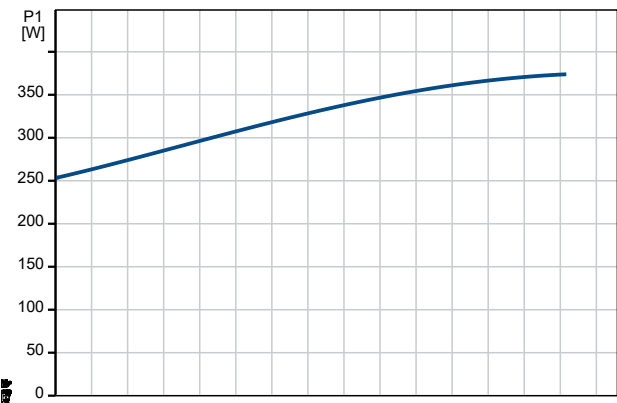
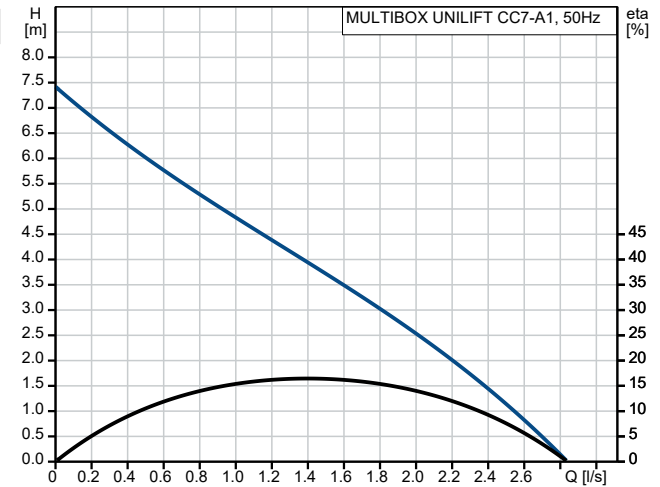

On request MULTIBOX UNILIFT CC7-A1 50 Hz

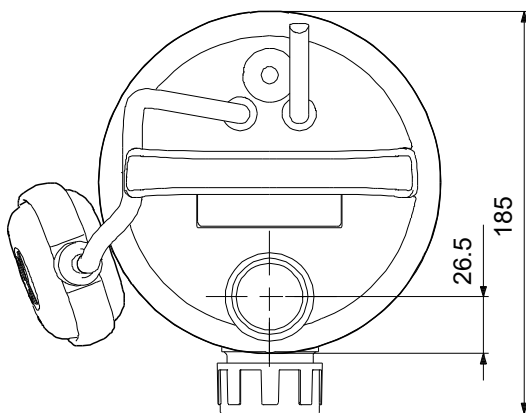
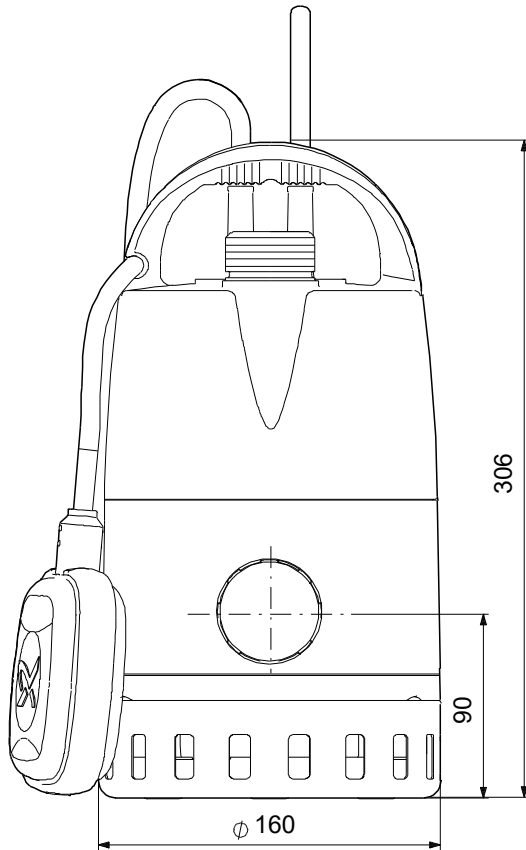

Note! All units are in [mm] unless others are stated.
Disclaimer: This simplified dimensional drawing does not show all details.

