

Qty.	Description
1	<p data-bbox="204 450 331 479"><b>MLD.32.3.2</b></p>  <p data-bbox="592 797 1062 822"><b>Note! Product picture may differ from actual product</b></p> <p data-bbox="204 831 480 855">Product No.: On request</p> <p data-bbox="204 891 1385 965">Supplied as complete unit ready for installation, MULTILIFT consist of a fully integrated collecting tank with two pumps and submersible motors, non-return valve with integrated Y-branch pipe, discharge adapter with flexible connection piece DN100 mounted on the collecting tank and a pre-wired controller including a level sensor.</p> <p data-bbox="204 1005 1433 1057">The fully integrated collecting tank has all necessary ports for the connection of inlet pipe, discharge pipe, vent pipe and a manually operated diaphragm pump (accessory).</p> <p data-bbox="204 1095 1313 1120">The collecting tank contains 2 inlet sockets. Main inlet DN150 on the stepped tank and DN50 on the top.</p> <p data-bbox="204 1155 1286 1209">MULTILIFT corrosion-free polyethylen collecting tanks are gas- and odour-proof as well as watertight. The chamfered bottom design ensures a reduction of residual water and less sedimentation.</p> <p data-bbox="204 1245 1098 1330">The pump features a Vortex impeller and a maintenance free submersible motor. The oil chamber is with physiological harmless oil filling between two shaft seals. Direction of rotation can be observed from outside over the shaft below the eye bolt.</p> <p data-bbox="204 1366 1437 1417">The LC 231 or LC 241 level controllers offer a comprehensive range of features for control and monitoring of pumps in MULTILIFTS.</p> <p data-bbox="204 1424 1422 1476">The controllers are designed for level control, monitoring and protection of Grundfos lifting stations with one or two pumps.</p> <p data-bbox="204 1482 1334 1507">An analogue level sensor is integrated into the controller and connected to the sensor tube by an air hose.</p> <p data-bbox="204 1543 1449 1594">The controller is pre-set from factory to the lowest possible starting level. Adjustment to a higher starting level can be done with the Grundfos GO app.</p> <p data-bbox="204 1601 1377 1686">With the Grundfos GO app, all detailed pump settings can be easily configured, monitored and commissioned. The display also offers the possibility to change the operating mode from auto to manual start/stop. The controller is equipped with configurable input/output terminals.</p> <p data-bbox="204 1722 1458 1774">The controller integrates seamlessly into the Grundfos range of communication modules, ensuring an easy fit into any supervisory system such as SCADA or Grundfos CLOUD.</p> <p data-bbox="204 1780 1449 1832">With the built-in motor protection, and the current measurement, the LC controller provide a service indicator function that helps keep track of when service is needed.</p> <p data-bbox="204 1839 1054 1863">The controller maintains a detailed alarm and warning log with the last 20 alerts.</p> <p data-bbox="204 1870 1453 1921">The alarm log can be accessed remotely via SCADA or Grundfos CLOUD. You can also use Grundfos GO to inspect the logs in localized, translated text for easy troubleshooting and remedial measures at the pumping station.</p> <p data-bbox="204 1980 1174 2004">Configurable input/output terminals that can be used as digital input/output, analogue input.</p> <p data-bbox="204 2040 1358 2065">Prevent the mains load when several pumping stations are started up at the same time with power-on delay.</p>

**Project:****Reference Number:****Client:****Client Number:****Contact:**

Qty.	Description
1	<ul style="list-style-type: none"><li>- Selection of automatic alarm resetting</li><li>- Setting of stop delays matching the actual operating conditions</li><li>- Shows the actual liquid level</li><li>- Alarm indication via a build in buzzer</li><li>- Alarm indication of:<ul style="list-style-type: none"><li>- Power/current overload</li><li>- High water level</li><li>- Optional high water level alarm (needs additional level switch)</li><li>- Incorrect phase sequences or missing phase</li><li>- Sensor inconsistency or failure</li><li>- Intrusion detection</li><li>- Water on floor</li><li>- Too many restarts</li><li>- Pump overheating and moisture detection</li></ul></li></ul> <p>The MULTILIFT range is designed according to the EN12050-1 standard, approved and monitored by external institute LGA. Further approvals are VDE, GHOST, CB, EMV</p> <p>Technical: Pump speed on which pump data are based: 2890 rpm Rated flow: 5.5 l/s Maximum flow: 16.7 l/s Rated head: 13.9 m Type of impeller: VORTEX Max. Particle: 50 mm Approvals: CE,EAC,MORO,UKCA,SEPRO Non-return valve type: Flap valve</p> <p>Materials: Tank: PLASTIC LDPE Gasket: NBR</p> <p>Installation: Range of ambient temperature: 0 .. 40 °C Type of outlet connection: DIN Size of outlet connection: DN 80 Pressure rating for connection: PN 6</p> <p>Liquid: Liquid temperature range: 0 .. 40 °C Density: 998.2 kg/m<sup>3</sup></p> <p>Electrical data: Power input P1: 4 kW Rated power - P2: 3.4 kW Mains frequency: 50 Hz Rated voltage: 3 x 400 V Voltage tolerance: +10/-14 % Max starts per hour: 60 Rated current: 2 X 6,7 A Cos phi - power factor: 0.86 Motor efficiency at full load: 85.4 %</p>



Company name:

Created by:

Phone:

Date: 29/11/2023

Project:

Reference Number:

Client:

Client Number:

Contact:

Qty.	Description
1	<p>Number of poles: 2 Start. method: direct-on-line Enclosure class (IEC 34-5): IP68 Insulation class (IEC 85): F Built-in motor protection: BIMETAL THERMAL SWITCH Length of cable: 1.5 m Power plug: CEE 3P+N+E</p> <p>Controls: Type of control box: LC231</p> <p>Tank: Total volume of tank(s): 270 l Total effective volume of collecting tank at 180 mm inlet: 190 l</p> <p>Others: Net weight: 136 kg Gross weight: 159 kg Danish VVS No.: 154036232 Finnish LVI No.: 4965391 Country of origin: DE Custom tariff no.: 84137021 Environmental approvals: WEEE</p>



Company name:  
Created by:  
Phone:

Date: 29/11/2023

Project:  
Reference Number:

Client:  
Client Number:  
Contact:

### On request MLD.32.3.2 50 Hz

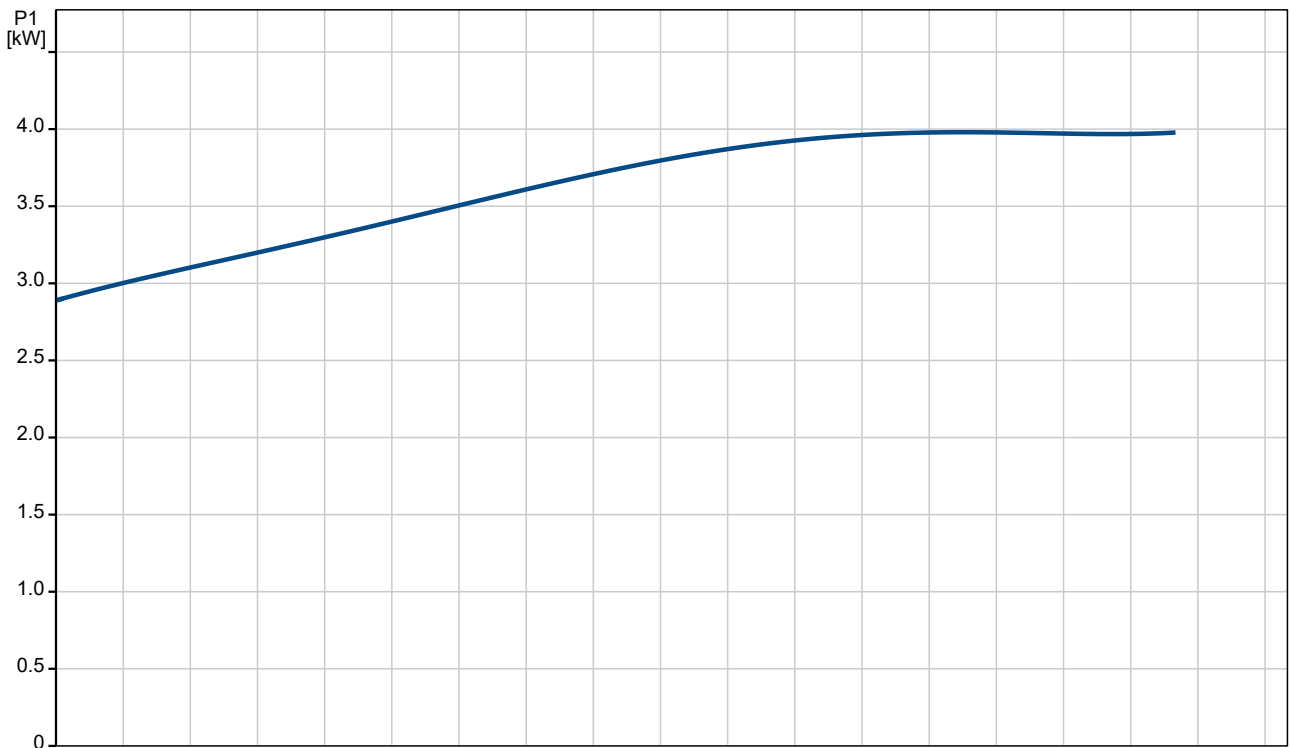
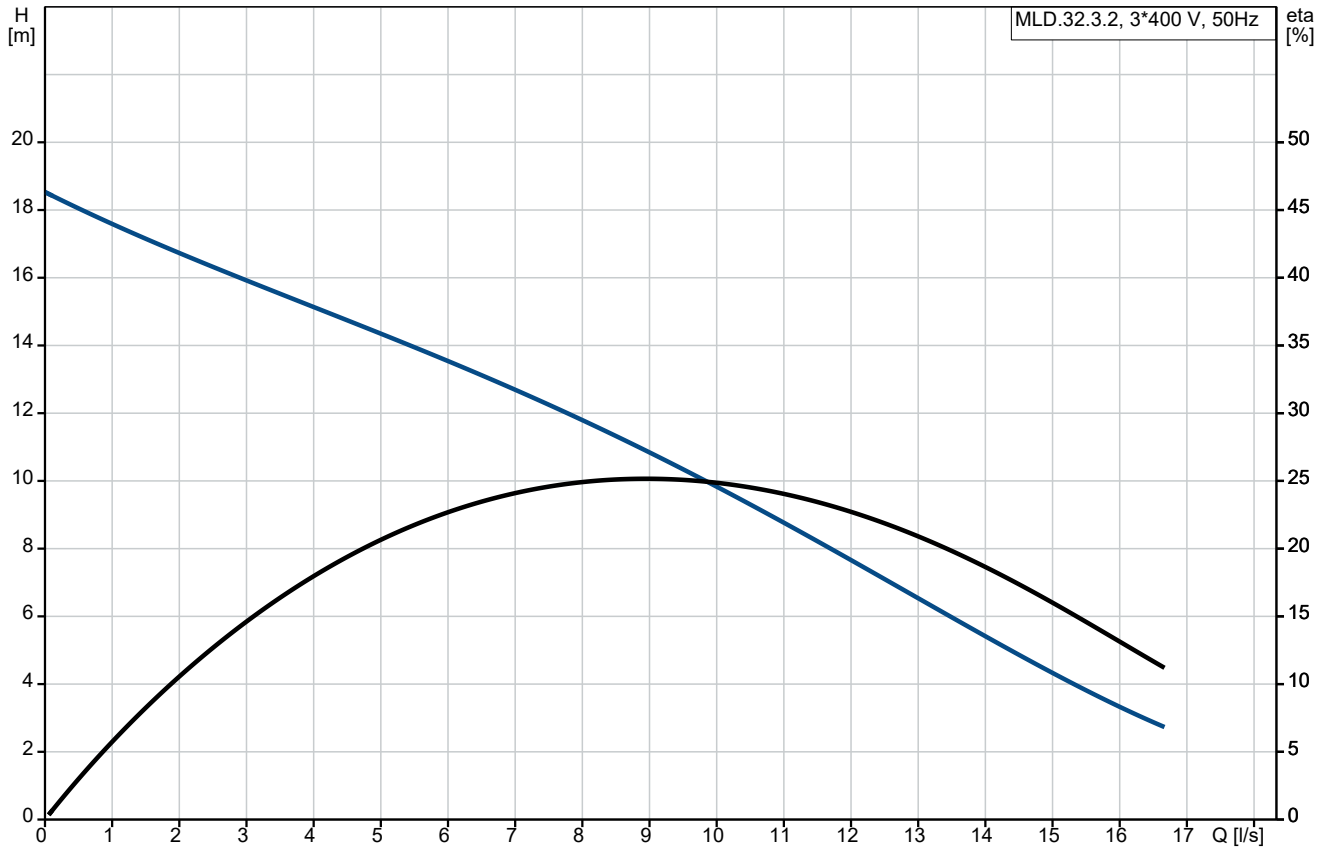

**Project:**

Reference Number:

**Client:**

Client Number:

Contact:

Description	Value
<b>General information:</b>	
Product name:	MLD.32.3.2
Product No:	On request
EAN number:	On request
<b>Technical:</b>	
Pump speed on which pump data are based:	2890 rpm
Rated flow:	5.5 l/s
Maximum flow:	16.7 l/s
Rated head:	13.9 m
Maximum head:	18.5 m
Type of impeller:	VORTEX
Max. Particle:	50 mm
Approvals:	CE,EAC,MORO,UKCA,SE PRO
Non-return valve type:	Flap valve
<b>Materials:</b>	
Tank:	PLASTIC
Tank:	LDPE
Gasket:	NBR
<b>Installation:</b>	
Range of ambient temperature:	0 .. 40 °C
Type of outlet connection:	DIN
Size of outlet connection:	DN 80
Pressure rating for connection:	PN 6
<b>Liquid:</b>	
Liquid temperature range:	0 .. 40 °C
Density:	998.2 kg/m³
<b>Electrical data:</b>	
Power input P1:	4 kW
Rated power - P2:	3.4 kW
Mains frequency:	50 Hz
Rated voltage:	3 x 400 V
Voltage tolerance:	+10/-14 %
Max starts per hour:	60
Rated current:	2 X 6,7 A
Cos phi - power factor:	0.86
Motor efficiency at full load:	85.4 %
Number of poles:	2
Start. method:	direct-on-line
Enclosure class (IEC 34-5):	IP68
Insulation class (IEC 85):	F
Built-in motor protection:	BIMETAL THERMAL SWITCH
Length of cable:	1.5 m
Motor cable:	4 m
Cable type:	H07 RN-F
Power plug:	CEE 3P+N+E
Mains cable:	H05 VV-F
<b>Controls:</b>	
Type of control box:	LC231
Operation mode:	S3-50%,1MIN
<b>Tank:</b>	
Total volume of tank(s):	270 l

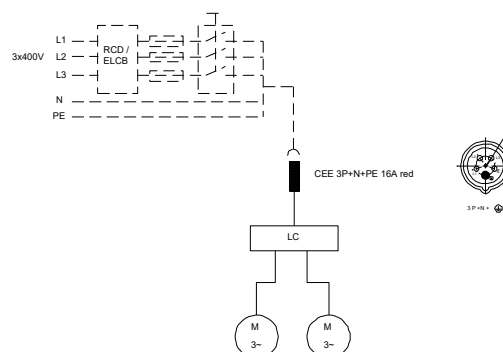
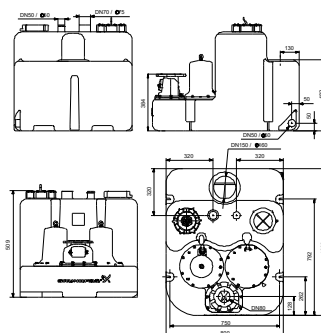
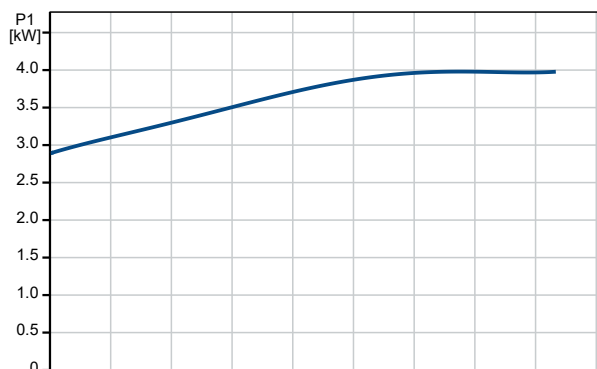



Company name:

Created by:

Phone:

Date: 29/11/2023

Project:

Reference Number:

Client:

Client Number:

Contact:

Description	Value
Total effective volume of collecting tank at 180 mm inlet:	190 l
<b>Others:</b>	
Net weight:	136 kg
Gross weight:	159 kg
Danish VVS No.:	154036232
Finnish LVI No.:	4965391
Country of origin:	DE
Custom tariff no.:	84137021
Environmental approvals:	WEEE

## On request MLD.32.3.2 50 Hz

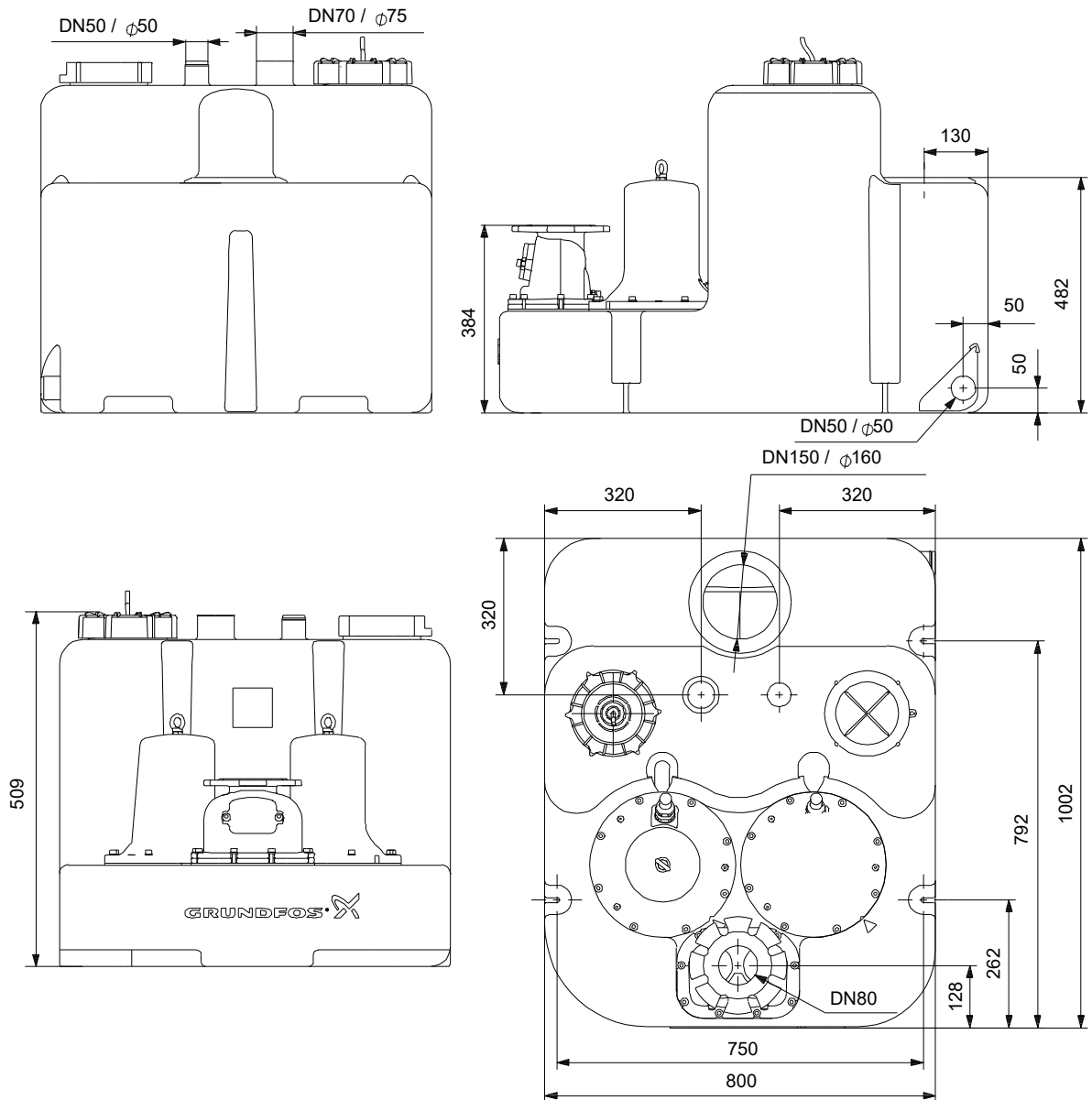

Note! All units are in [mm] unless others are stated.  
Disclaimer: This simplified dimensional drawing does not show all details.

## On request MLD.32.3.2 50 Hz

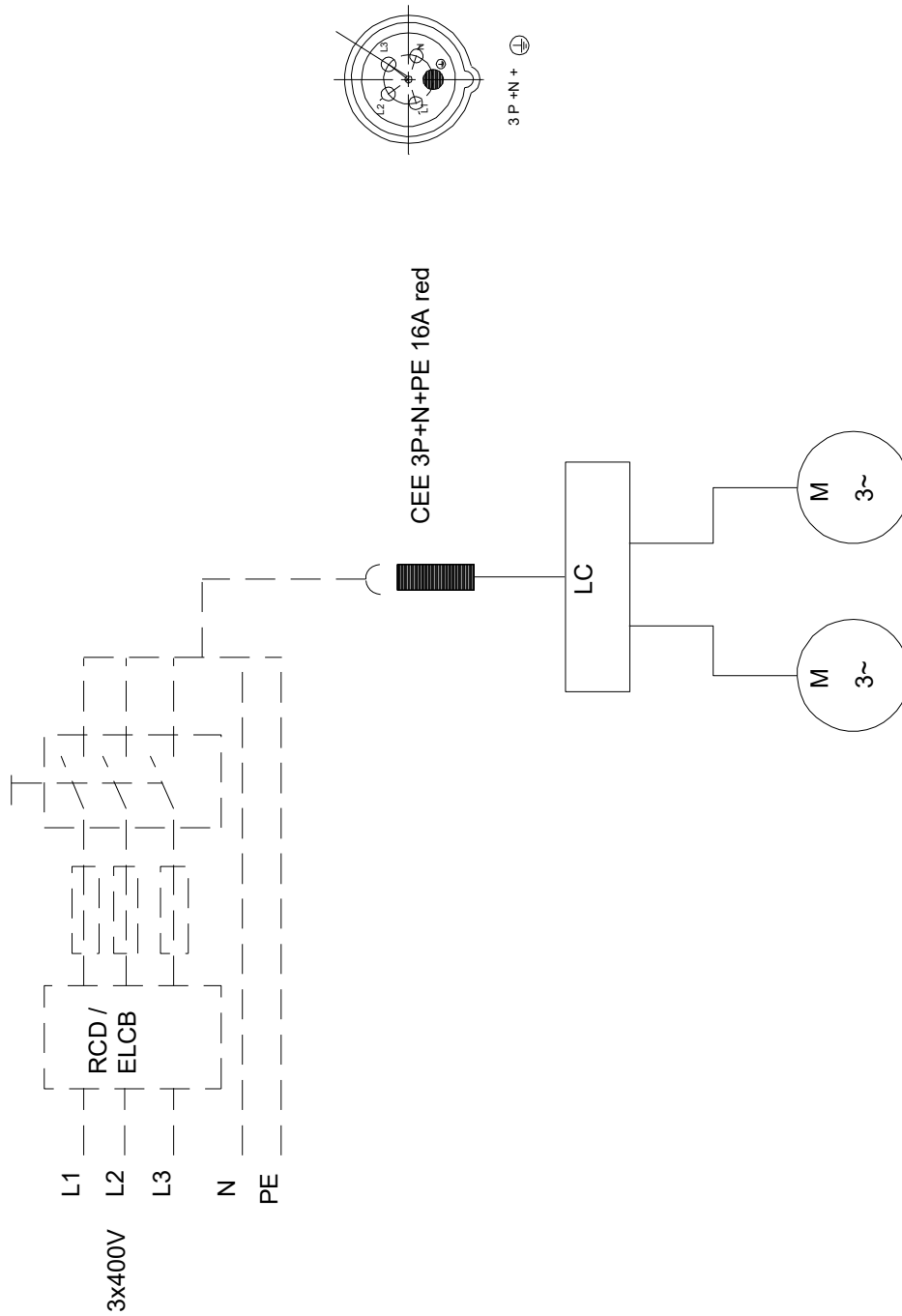

Note! All units are in [mm] unless others are stated.

