

# Submittal Data

|                       |                  |             |
|-----------------------|------------------|-------------|
| PROJECT:              | UNIT TAG:        | QUANTITY:   |
| REPRESENTATIVE: _____ | TYPE OF SERVICE: | DATE: _____ |
| ENGINEER:             | SUBMITTED BY:    | DATE:       |
| CONTRACTOR:           | APPROVED BY:     | DATE:       |
|                       | ORDER NO.:       | DATE:       |



## TP 32-80/2 A-O-I-BQQE-CW1

Grundfos TP (B), (I) pumps with pump housing in bronze or stainless steel and are single-stage, close-coupled in-line centrifugal pumps with mechanical shaft seal and primarily for applications such as hot water recirculation. The pumps are fitted with fixed speed motors.

Note! Product picture may differ from actual product

| Conditions of Service | Pump Data                                    | Motor Data                       |
|-----------------------|----------------------------------------------|----------------------------------|
|                       | Max pressure at stated temp: 10 bar / 120 °C | Rated voltage: 220-230 V         |
|                       | Liquid temperature range: -25 .. 120 °C      | Mains frequency: 50 Hz           |
|                       | Maximum ambient temperature: 40 °C           | Enclosure class: 55 Dust/Jetting |
|                       | Shaft seal: BQQE                             | Insulation class: F              |
|                       | Product number: On request                   | Motor protection: PTO            |
|                       |                                              | Motor type: 71A                  |
|                       |                                              | Eta 1/1: 66.0-66.0 %             |

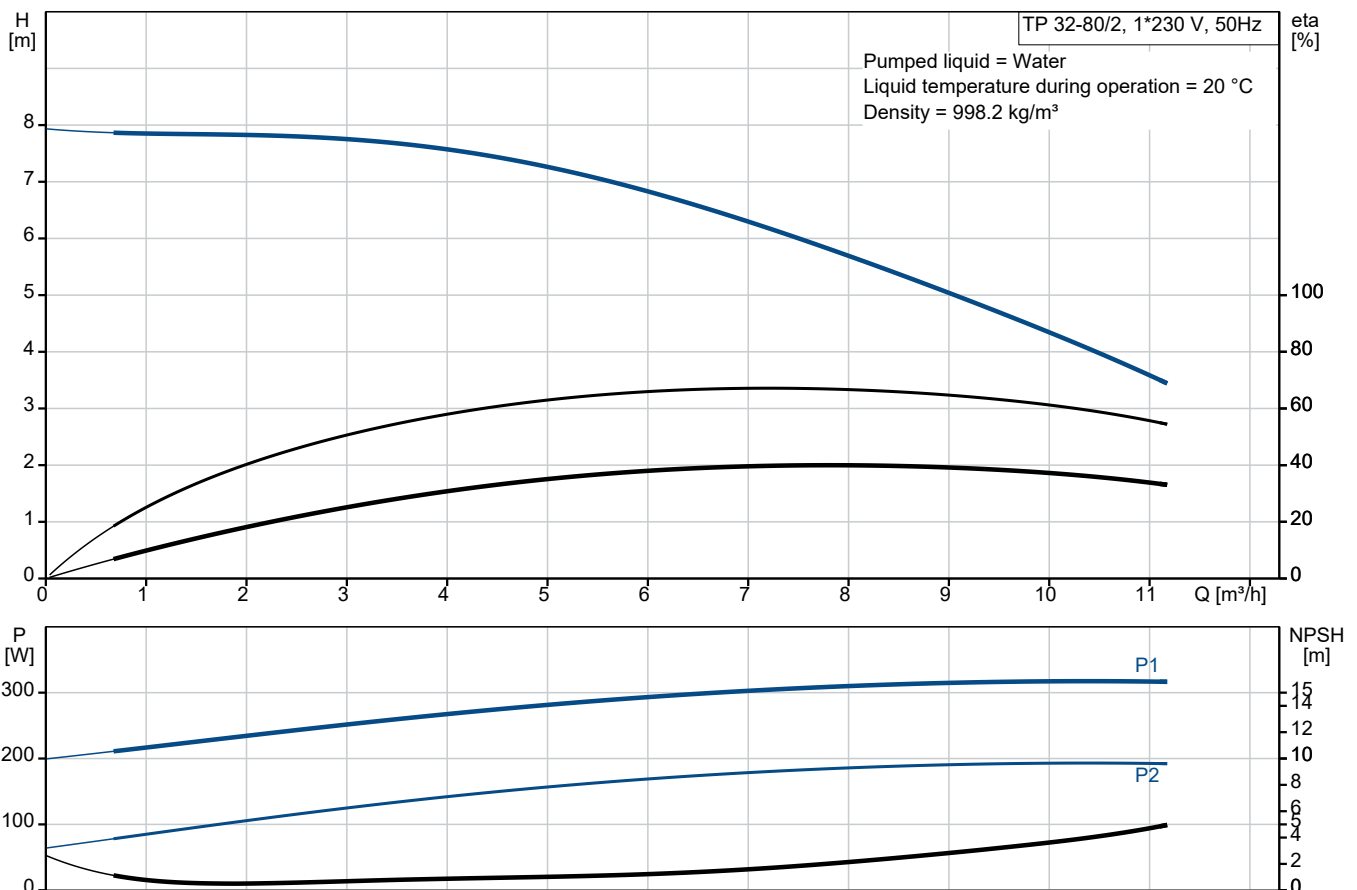

# Submittal Data

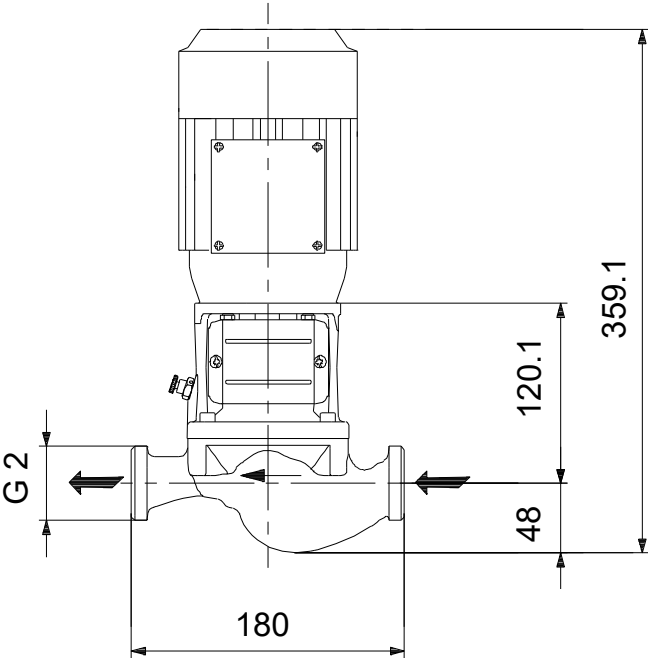
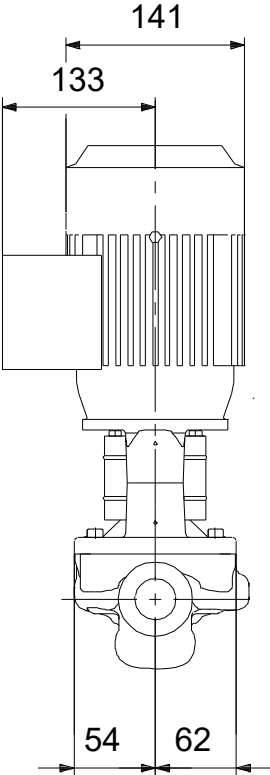

**Materials:**  
Pump housing: Stainless steel  
Pump housing: ASTM CF8  
Impeller: Composite  
Material code: I

**Qty. Description**

1 TP 32-80/2 A-O-I-BQQE-CW1



**Note! Product picture may differ from actual product**

Product No.: On request

Single-stage, close-coupled, volute pump with in-line suction and discharge ports of identical diameter. The pump is of the top-pull-out design, i.e. the power head (motor, pump head and impeller) can be removed for maintenance or service while the pump housing remains in the pipework.

The pump is fitted with an unbalanced rubber bellows seal. The shaft seal is according to EN 12756. The pump is fitted with a fan-cooled asynchronous motor.

The stainless-steel pump housing makes the pump suitable for circulation of hot water.

The product's minimum efficiency index (MEI) is greater or equal to 0.70. This is by the Commission Regulation (EU) considered as an indicative benchmark for best-performing water pump available on the market as from 1 January 2013.

Cast-iron parts have an epoxy-based coating made in a cathodic electro-deposition (CED) process. CED is a high-quality dip-painting process where an electrical field around the products ensures deposition of paint particles as a thin, well-controlled layer on the surface.

## Pump

The pump housing is provided with a replaceable stainless steel/PTFE neck ring to reduce the amount of liquid running from the discharge side of the impeller to the suction side.

The impeller is secured with a split cone pressed onto the shaft.

The pump is fitted with an unbalanced rubber bellows seal with torque transmission across the spring and around the bellows. Due to the bellows, the seal does not wear the shaft, and the axial movement is not prevented by deposits on the shaft.

Seal faces:

- Rotating seal ring material: silicon carbide (SiC)
- Stationary seat material: silicon carbide (SiC)

This material pairing is used where higher corrosion resistance is required. The high hardness of this material pairing offers good resistance against abrasive particles.

Secondary seal material: EPDM (ethylene-propylene rubber)

EPDM has excellent resistance to hot water. EPDM is not suitable for mineral oils.

A circulation of liquid through the duct of the air vent screw ensures lubrication and cooling of the shaft seal.

The motor stool forms connection between the pump housing and the motor, and is equipped with a manual air vent screw for venting of the pump housing and the shaft seal chamber. The sealing between motor stool and pump housing is an O-ring or a flat gasket.

The central part of the motor stool is provided with guards for protection against the shaft and coupling. Motor and pump shaft are connected via a shell coupling.

## Motor

The motor is a totally enclosed, fan-cooled motor with principal dimensions to IEC and DIN standards. Electrical tolerances comply with IEC 60034.

The motor is flange-mounted with tapped-hole flange (FT).

Motor-mounting designation in accordance with IEC 60034-7: IM B 14, IM V 18 (Code I) / IM 3601, IM 3611 (Code II).

The motor efficiency is classified as IE2 in accordance with IEC 60034-30.

The motor has built-in thermal protection (PTO current and temperature sensors) in accordance with IEC 60034-11 and requires no further motor protection. The protection reacts to both slow- and quick-rising temperatures, e.g. constant overload and stalled conditions.

| Qty. | Description                                                                                                                                                                                                                                                                                                                                                                                                                                                                                                                                                                                                                                                                                                                                                                                                                                                                                                                                                                                                                                                                                                                                                                                                                                                                                                                                                                                                                                                                                                                                                                                                                                                                                                                                                                                                                                                                                                                                                                                                                                                                                                                                                                                                                                                                                                                                                                                                                                                                                                                                                                                                                                                                                                                                                                                                                                                                                                                                                                                                                                                                                                                                                                                                                                                                                                                                                                                                                                                                                                                                                                                                                                                                                                                                                                                                                                                                                                                                                                                                                                                                                                                                                                                                                                                                                                                                                                                   |
|------|-----------------------------------------------------------------------------------------------------------------------------------------------------------------------------------------------------------------------------------------------------------------------------------------------------------------------------------------------------------------------------------------------------------------------------------------------------------------------------------------------------------------------------------------------------------------------------------------------------------------------------------------------------------------------------------------------------------------------------------------------------------------------------------------------------------------------------------------------------------------------------------------------------------------------------------------------------------------------------------------------------------------------------------------------------------------------------------------------------------------------------------------------------------------------------------------------------------------------------------------------------------------------------------------------------------------------------------------------------------------------------------------------------------------------------------------------------------------------------------------------------------------------------------------------------------------------------------------------------------------------------------------------------------------------------------------------------------------------------------------------------------------------------------------------------------------------------------------------------------------------------------------------------------------------------------------------------------------------------------------------------------------------------------------------------------------------------------------------------------------------------------------------------------------------------------------------------------------------------------------------------------------------------------------------------------------------------------------------------------------------------------------------------------------------------------------------------------------------------------------------------------------------------------------------------------------------------------------------------------------------------------------------------------------------------------------------------------------------------------------------------------------------------------------------------------------------------------------------------------------------------------------------------------------------------------------------------------------------------------------------------------------------------------------------------------------------------------------------------------------------------------------------------------------------------------------------------------------------------------------------------------------------------------------------------------------------------------------------------------------------------------------------------------------------------------------------------------------------------------------------------------------------------------------------------------------------------------------------------------------------------------------------------------------------------------------------------------------------------------------------------------------------------------------------------------------------------------------------------------------------------------------------------------------------------------------------------------------------------------------------------------------------------------------------------------------------------------------------------------------------------------------------------------------------------------------------------------------------------------------------------------------------------------------------------------------------------------------------------------------------------------------------|
| 1    | <p data-bbox="204 342 1453 389">As the thermal protection incorporates automatic reset, the motor must be connected in a way which ensures that the automatic reset cannot cause accidents.</p> <p data-bbox="204 432 512 461"><b>Further product details</b></p> <p data-bbox="204 465 1453 539">Cast-iron parts have an epoxy-based coating made in a cathodic electro-deposition (CED) process. CED is a high-quality dip-painting process where an electrical field around the products ensures deposition of paint particles as a thin, well-controlled layer on the surface.</p> <p data-bbox="204 611 400 640"><b>Technical data</b></p> <p data-bbox="204 678 300 701">Controls:</p> <p data-bbox="204 705 624 734">Frequency converter:                      None</p> <p data-bbox="204 768 276 790">Liquid:</p> <p data-bbox="204 795 703 824">Liquid temperature range:                -25 .. 120 °C</p> <p data-bbox="204 857 316 880">Technical:</p> <p data-bbox="204 884 815 913">Pump speed on which pump data are based:    2830 rpm</p> <p data-bbox="204 918 671 947">Rated flow:                                        7.71 m<sup>3</sup>/h</p> <p data-bbox="204 952 639 981">Rated head:                                        5.51 m</p> <p data-bbox="204 985 639 1014">Actual impeller diameter:                    79 mm</p> <p data-bbox="204 1019 639 1048">Code for shaft seal:                            BQQE</p> <p data-bbox="204 1052 767 1081">Curve tolerance:                                ISO9906:2012 3B2</p> <p data-bbox="204 1104 308 1126">Materials:</p> <p data-bbox="204 1131 719 1211">Pump housing:                                    Stainless steel<br/>                                                                   EN 1.4308<br/>                                                                   ASTM CF8</p> <p data-bbox="204 1223 719 1283">Impeller:                                            Composite<br/>                                                                   PES+30% GF</p> <p data-bbox="204 1317 323 1339">Installation:</p> <p data-bbox="204 1344 687 1373">Range of ambient temperature:            -30 .. 40 °C</p> <p data-bbox="204 1377 624 1406">Maximum operating pressure:                10 bar</p> <p data-bbox="204 1411 719 1440">Max pressure at stated temp:                10 bar / 120 °C</p> <p data-bbox="204 1444 576 1473">Type of connection:                            G</p> <p data-bbox="204 1478 624 1507">Size of connection:                            DN 32</p> <p data-bbox="204 1512 624 1541">Pressure rating for connection:            PN 10</p> <p data-bbox="204 1545 639 1574">Port-to-port length:                            180 mm</p> <p data-bbox="204 1579 624 1608">Flange size for motor:                        FT75</p> <p data-bbox="204 1619 363 1641">Electrical data:</p> <p data-bbox="204 1646 608 1675">Motor type:                                        71A</p> <p data-bbox="204 1680 655 1709">Rated power - P2:                                0.25 kW</p> <p data-bbox="204 1713 624 1742">Mains frequency:                                50 Hz</p> <p data-bbox="204 1747 719 1776">Rated voltage:                                    1 x 220-230 V</p> <p data-bbox="204 1780 687 1809">Rated current:                                    1.80-1.80 A</p> <p data-bbox="204 1814 671 1843">Starting current:                                450-490 %</p> <p data-bbox="204 1848 671 1877">Cos phi - power factor:                        0.99-0.98</p> <p data-bbox="204 1881 719 1910">Rated speed:                                      2840-2850 rpm</p> <p data-bbox="204 1915 608 1944">IE Efficiency class:                              IE2</p> <p data-bbox="204 1948 687 1977">Motor efficiency at full load:                66.0-66.0 %</p> <p data-bbox="204 1982 687 2011">Motor efficiency at 3/4 load:                62.8-60.3 %</p> <p data-bbox="204 2016 687 2045">Motor efficiency at 1/2 load:                52.7-49.8 %</p> <p data-bbox="204 2049 576 2078">Number of poles:                                2</p> <p data-bbox="204 2083 719 2112">Enclosure class (IEC 34-5):                55 Dust/Jetting</p> <p data-bbox="204 2116 576 2145">Insulation class (IEC 85):                    F</p> |



Company name:

Created by:

Phone:

Date:

29/11/2023

| Qty. | Description |
|------|-------------|
|------|-------------|

|   |                                       |
|---|---------------------------------------|
| 1 | Motor No: 92696830                    |
|   | Others:                               |
|   | Minimum efficiency index, MEI ≥: 0.70 |
|   | Net weight: 9.8 kg                    |
|   | Gross weight: 11.8 kg                 |
|   | Shipping volume: 0.041 m <sup>3</sup> |
|   | Danish VVS No.: 381874080             |
|   | Country of origin: HU                 |
|   | Custom tariff no.: 84137051           |

## On request TP 32-80/2 A-O-I-BQQE-CW1 50 Hz

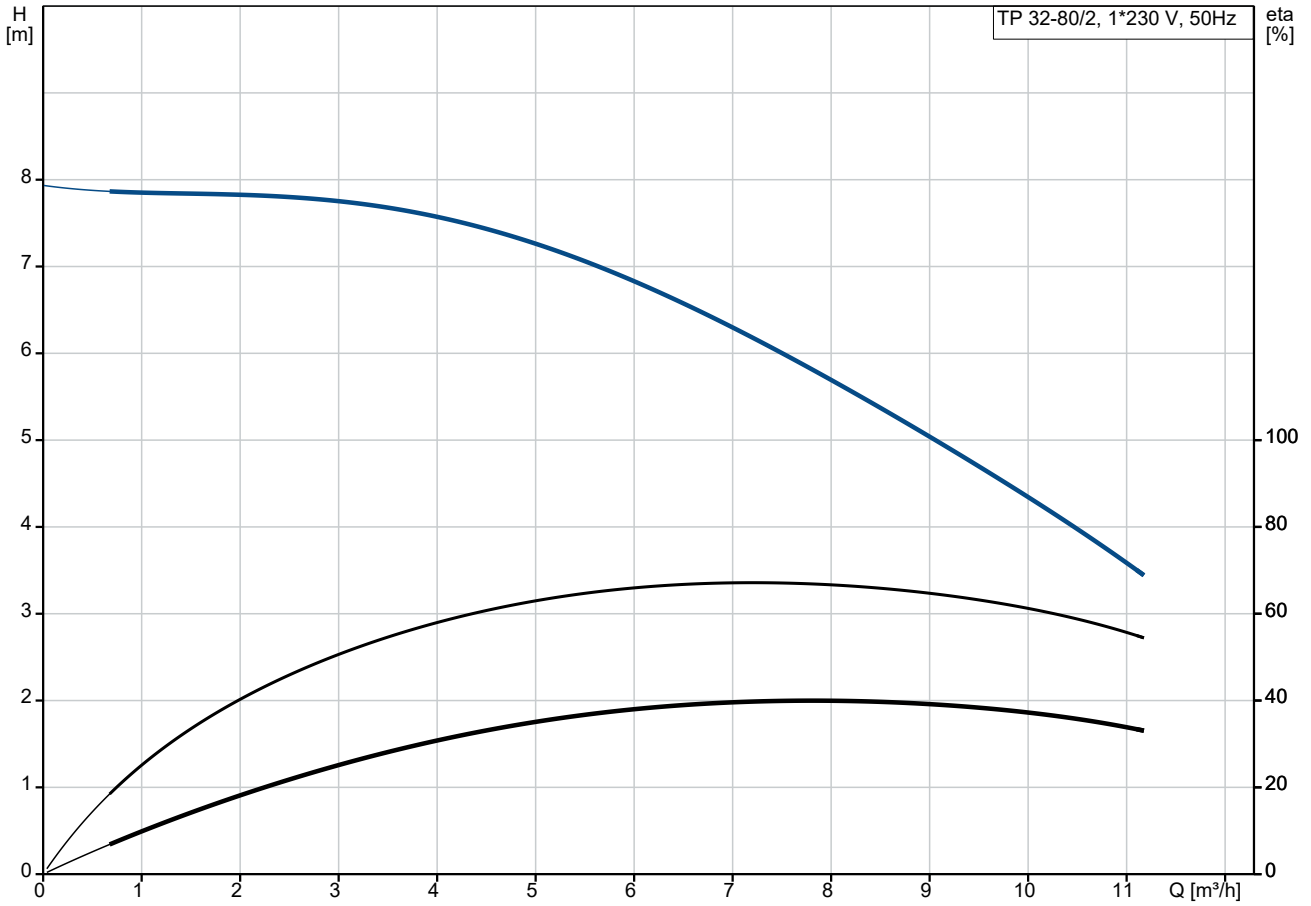

Pumped liquid = Water  
 Liquid temperature during operation = 20 °C  
 Density = 998.2 kg/m³

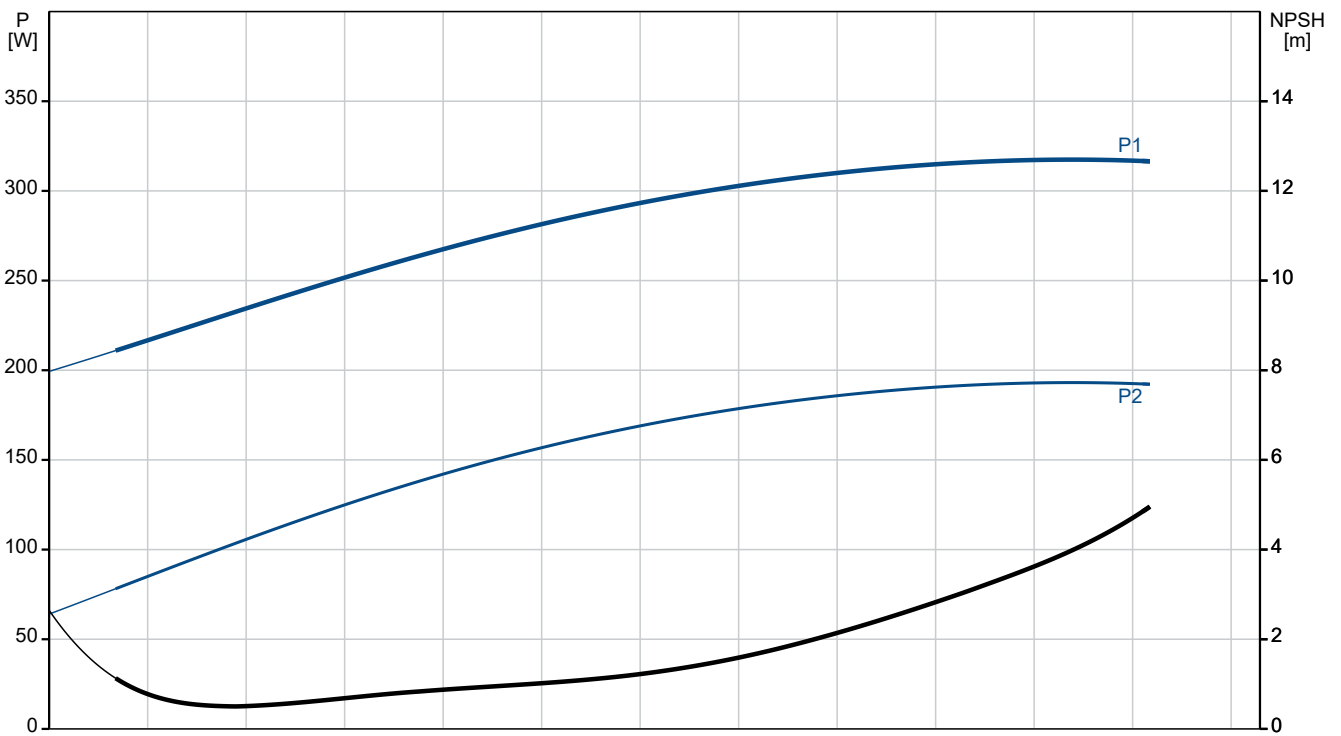

| Description                              | Value                        |
|------------------------------------------|------------------------------|
| <b>General information:</b>              |                              |
| Product name:                            | TP 32-80/2<br>A-O-I-BQQE-CW1 |
| Product No:                              | On request                   |
| EAN number:                              | On request                   |
| <b>Technical:</b>                        |                              |
| Pump speed on which pump data are based: | 2830 rpm                     |
| Rated flow:                              | 7.71 m <sup>3</sup> /h       |
| Rated head:                              | 5.51 m                       |
| Maximum head:                            | 80 dm                        |
| Actual impeller diameter:                | 79 mm                        |
| Code for shaft seal:                     | BQQE                         |
| Curve tolerance:                         | ISO9906:2012 3B2             |
| Pump version:                            | A                            |
| <b>Materials:</b>                        |                              |
| Pump housing:                            | Stainless steel              |
| Pump housing:                            | EN 1.4308                    |
| Pump housing:                            | ASTM CF8                     |
| Impeller:                                | Composite                    |
| Impeller:                                | PES+30% GF                   |
| Material code:                           | I                            |
| <b>Installation:</b>                     |                              |
| Range of ambient temperature:            | -30 .. 40 °C                 |
| Maximum operating pressure:              | 10 bar                       |
| Max pressure at stated temp:             | 10 bar / 120 °C              |
| Type of connection:                      | G                            |
| Size of connection:                      | DN 32                        |
| Pressure rating for connection:          | PN 10                        |
| Port-to-port length:                     | 180 mm                       |
| Flange size for motor:                   | FT75                         |
| Connect code:                            | O                            |
| <b>Liquid:</b>                           |                              |
| Liquid temperature range:                | -25 .. 120 °C                |
| <b>Electrical data:</b>                  |                              |
| Motor type:                              | 71A                          |
| Rated power - P2:                        | 0.25 kW                      |
| Mains frequency:                         | 50 Hz                        |
| Rated voltage:                           | 1 x 220-230 V                |
| Rated current:                           | 1.80-1.80 A                  |
| Starting current:                        | 450-490 %                    |
| Cos phi - power factor:                  | 0.99-0.98                    |
| Rated speed:                             | 2840-2850 rpm                |
| IE Efficiency class:                     | IE2                          |
| Motor efficiency at full load:           | 66.0-66.0 %                  |
| Motor efficiency at 3/4 load:            | 62.8-60.3 %                  |
| Motor efficiency at 1/2 load:            | 52.7-49.8 %                  |
| Number of poles:                         | 2                            |
| Enclosure class (IEC 34-5):              | 55 Dust/Jetting              |
| Insulation class (IEC 85):               | F                            |
| Built-in motor protection:               | PTO                          |
| Motor No:                                | 92696830                     |
| <b>Controls:</b>                         |                              |
| Frequency converter:                     | None                         |
| <b>Others:</b>                           |                              |
| Minimum efficiency index, MEI ≥:         | 0.70                         |
| Net weight:                              | 9.8 kg                       |
| Gross weight:                            | 11.8 kg                      |

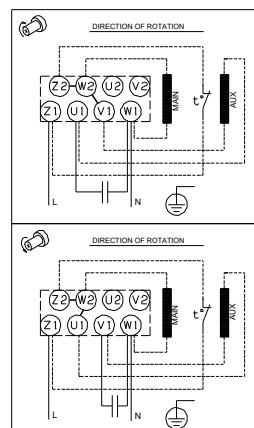
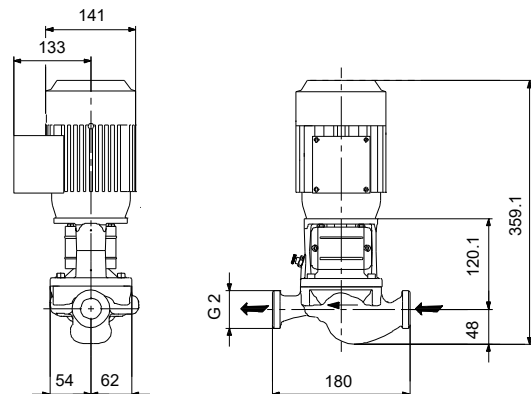
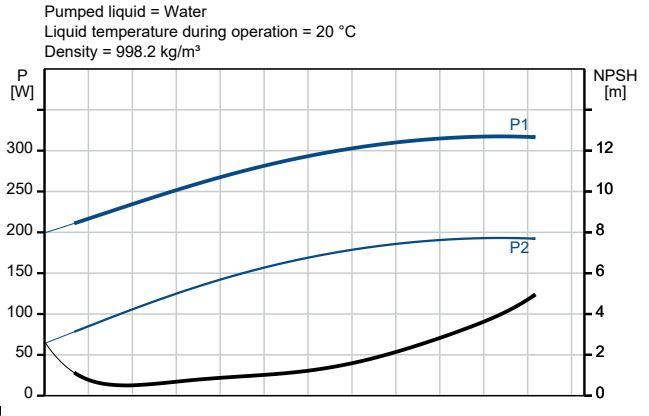
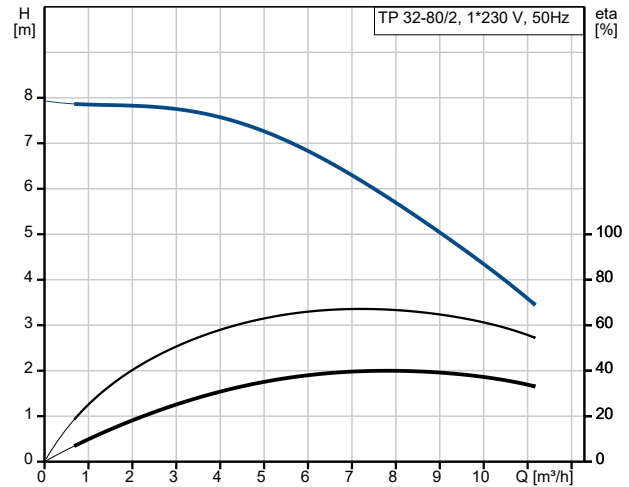



Company name:

Created by:

Phone:

Date:

29/11/2023

| Description        | Value                |
|--------------------|----------------------|
| Shipping volume:   | 0.041 m <sup>3</sup> |
| Danish VVS No.:    | 381874080            |
| Country of origin: | HU                   |
| Custom tariff no.: | 84137051             |

## On request TP 32-80/2 A-O-I-BQQE-CW1 50 Hz

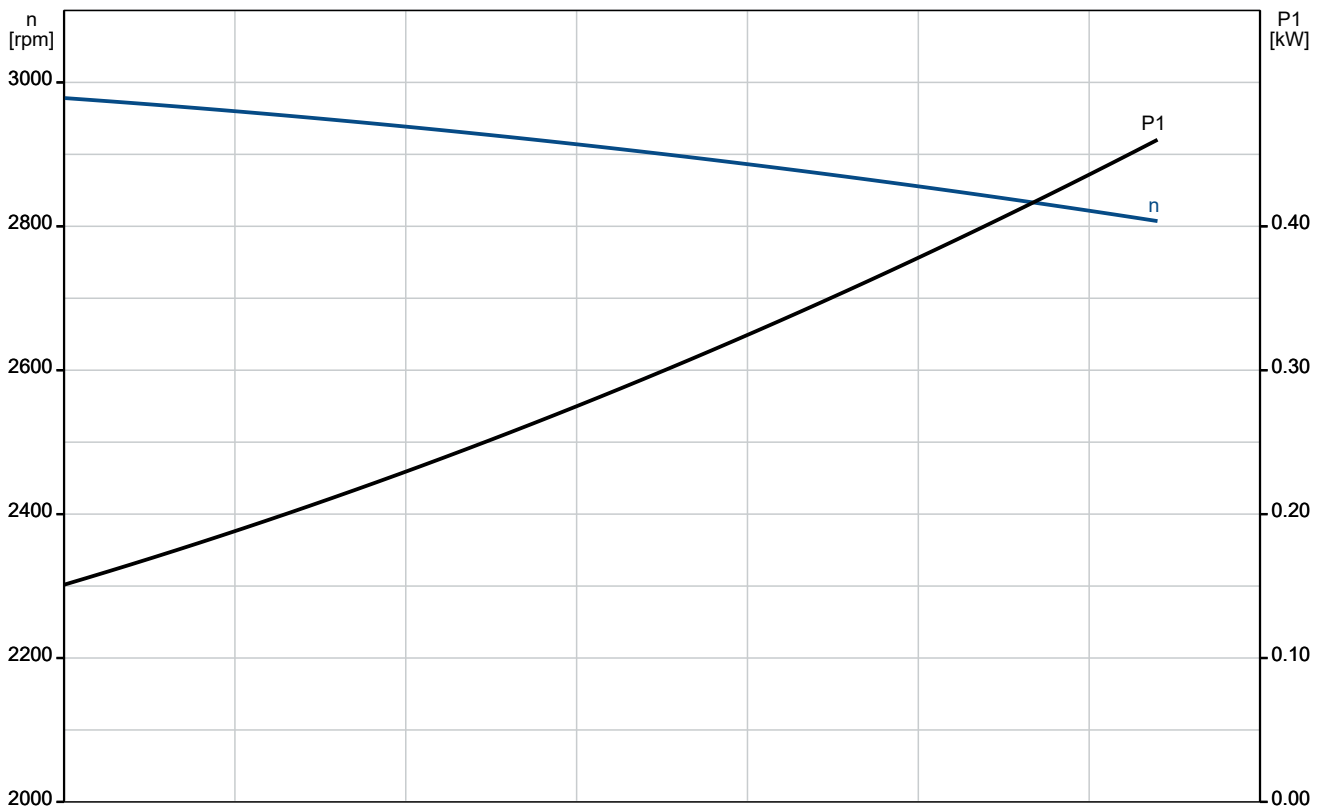
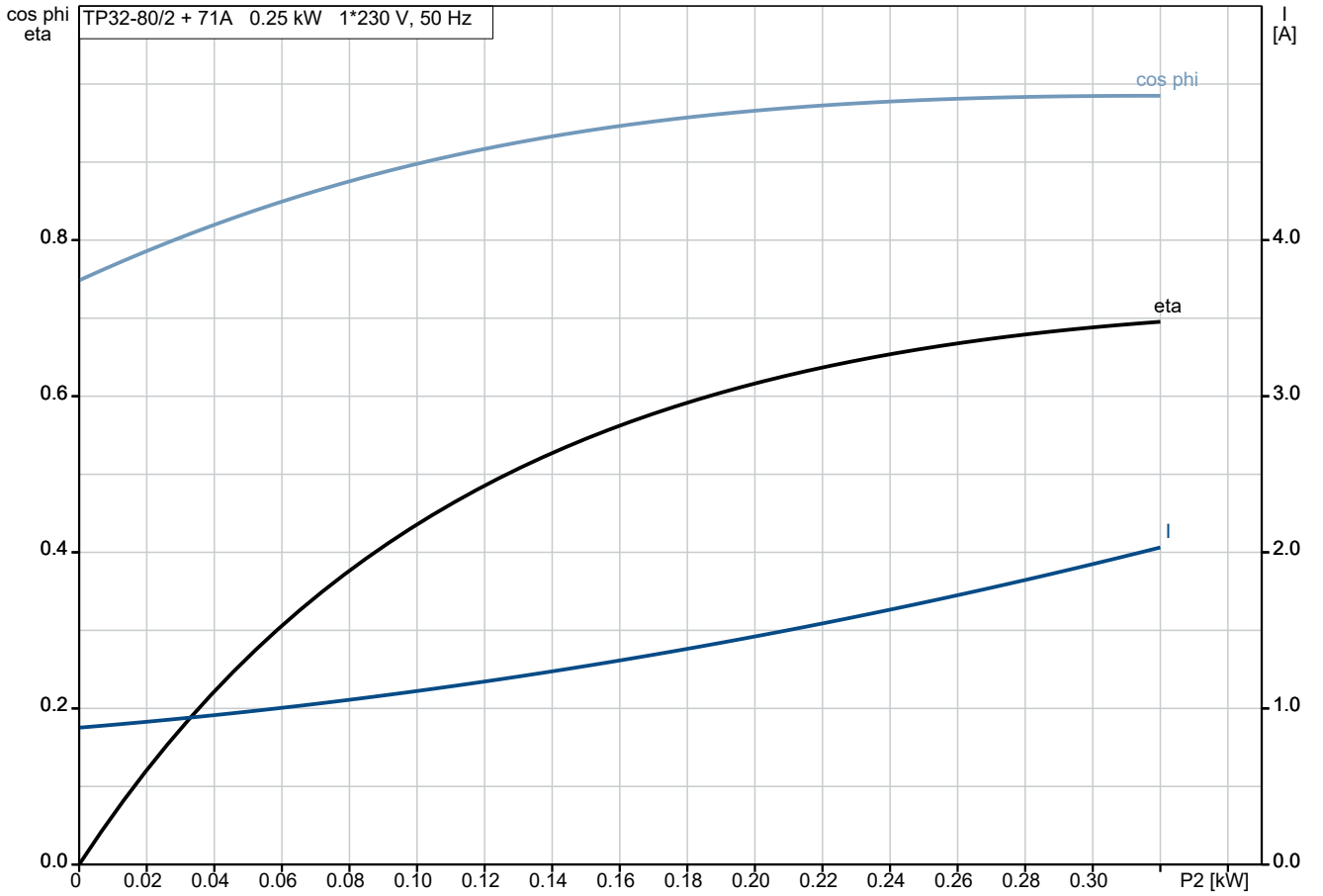

## On request TP 32-80/2 A-O-I-BQQE-CW1 50 Hz

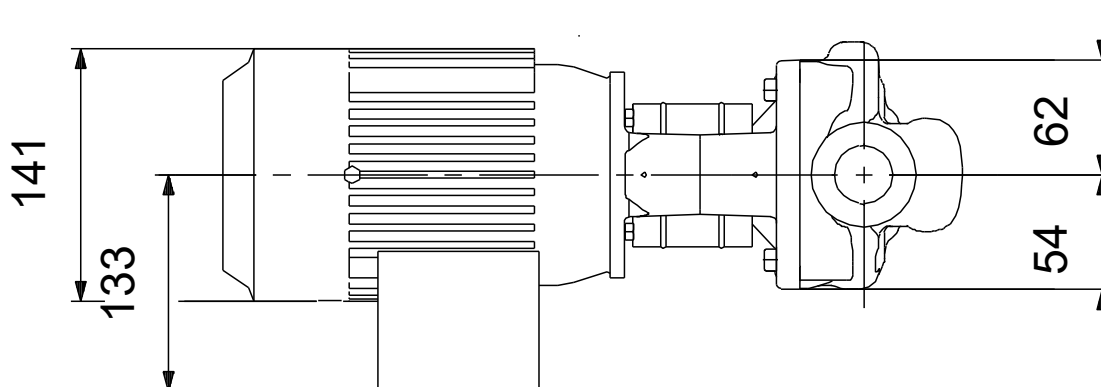
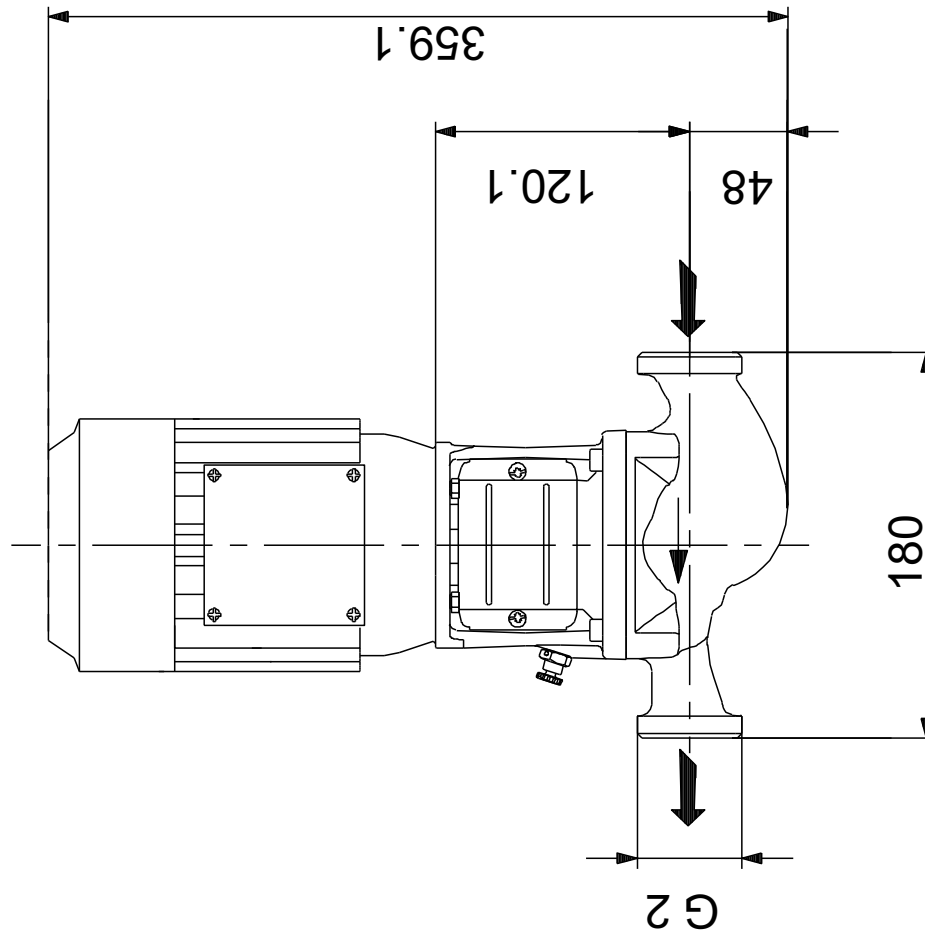

Note! All units are in [mm] unless others are stated.  
Disclaimer: This simplified dimensional drawing does not show all details.

## On request TP 32-80/2 A-O-I-BQQE-CW1 50 Hz

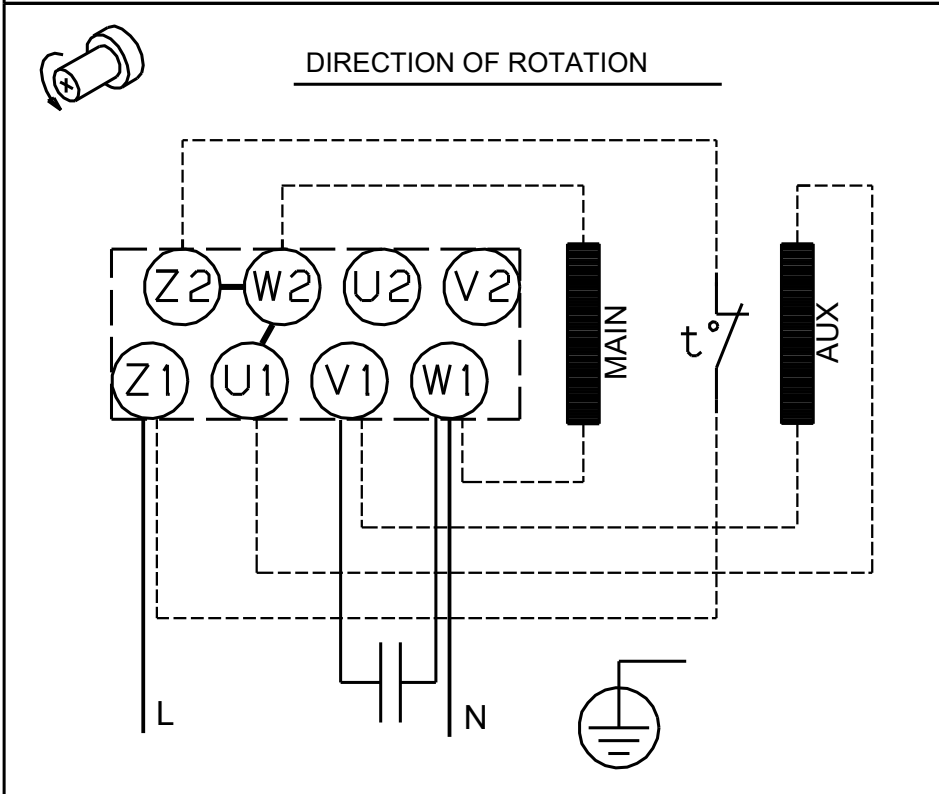
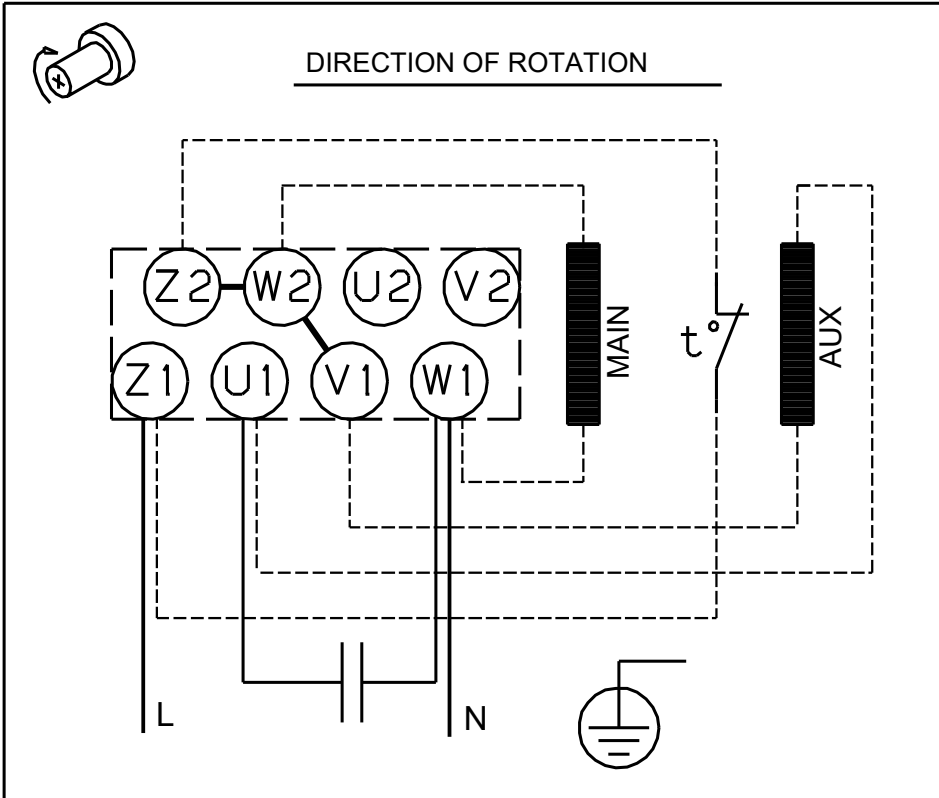

Note! All units are in [mm] unless others are stated.

