

**Qty. Description**

1 TP 100-1040/2 A3-F-Y-DQQE-1W1



**Note! Product picture may differ from actual product**

Product No.: On request

Single-stage, close-coupled, volute pump with in-line suction and discharge ports of identical diameter. The pump is of the top-pull-out design, i.e. the power head (motor, pump head and impeller) can be removed for maintenance or service while the pump housing remains in the pipework.

The pump is fitted with a balanced O-ring seal. The shaft seal is according to EN 12756. Pipework connection is via PN 25 DIN flanges (EN 1092-2 and ISO 7005-2).

The pump is fitted with a fan-cooled asynchronous motor.

The product's minimum efficiency index (MEI) is greater or equal to 0.70. This is by the Commission Regulation (EU) considered as an indicative benchmark for best-performing water pump available on the market as from 1 January 2013.

Cast-iron parts have an epoxy-based coating made in a cathodic electro-deposition (CED) process. CED is a high-quality dip-painting process where an electrical field around the products ensures deposition of paint particles as a thin, well-controlled layer on the surface.

**Pump**



- 1: Pump housing
- 2: Impeller
- 3: Stub shaft
- 4: Pump head/motor stool
- 5: Wear rings

The pump housing is provided with a replaceable brass neck ring to reduce the amount of liquid running from the outlet side of the impeller to the inlet side.

The impeller is secured to the shaft with a nut.

The pump is fitted with a balanced O-ring seal. Due to the balancing, this seal type is suitable for high-pressure applications. This seal type is excellent for high-viscosity, dirt- and fibre-containing liquids due to the spring location on the atmospheric side. The seal features a rigid torque-transmission design.

Seal faces:

- Rotating seal ring material: silicon carbide (SiC)
- Stationary seat material: silicon carbide (SiC)

This material pairing is used where higher corrosion resistance is required. The high hardness of this material pairing offers good resistance against abrasive particles.

Secondary seal material: EPDM (ethylene-propylene rubber)

Qty.	Description
1	<p>EPDM has excellent resistance to hot water. EPDM is not suitable for mineral oils.                      A circulation of liquid through the duct of the air vent screw ensures lubrication and cooling of the shaft seal.                      The flanges have tappings for mounting of pressure gauges.                      The motor stool forms connection between the pump housing and the motor, and is equipped with a manual air vent screw for venting of the pump housing and the shaft seal chamber. The sealing between motor stool and pump housing is an O-ring.                      The central part of the motor stool is provided with guards for protection against the shaft and coupling. The pump shaft is fastened directly on the motor shaft with key and set screws.                      The pump is mounted with a base plate.</p> <p><b>Motor</b>                      The motor is a totally enclosed, fan-cooled motor with principal dimensions to IEC and DIN standards. Electrical tolerances comply with IEC 60034.                      The motor is flange-mounted with free-hole flange (FF).                      Motor-mounting designation in accordance with IEC 60034-7: IM B 5, IM V 1 (Code I) / IM 3001, IM 3011 (Code II).                      The motor efficiency is classified as IE4 in accordance with IEC 60034-30-1.                      The motor has thermistors (PTC sensors) in the windings in accordance with DIN 44081/DIN 44082. The protection reacts to both slow- and quick-rising temperatures, e.g. constant overload and stalled conditions.                      Thermal switches must be connected to an external control circuit in a way which ensures that the automatic reset cannot cause accidents. The motors must be connected to a motor-protective circuit breaker according to local regulations.                      A variable speed drive makes adjustment of pump performance to any duty point possible. If the motor is to be connected to a variable speed drive, the pump must be ordered with an electrically insulated motor bearing.</p> <p><b>Further product details</b>                      Cast-iron parts have an epoxy-based coating made in a cathodic electro-deposition (CED) process. CED is a high-quality dip-painting process where an electrical field around the products ensures deposition of paint particles as a thin, well-controlled layer on the surface.</p> <p><b>Technical data</b></p> <p>Controls:                      Frequency converter:                      None</p> <p>Liquid:                      Liquid temperature range:              -40 .. 120 °C</p> <p>Technical:                      Pump speed on which pump data are based:    2984 rpm                      Rated flow:                                      292 m<sup>3</sup>/h                      Rated head:                                      95.98 m                      Actual impeller diameter:                    284 mm                      Code for shaft seal:                          DQQE                      Curve tolerance:                                ISO9906:2012 3B</p> <p>Materials:                      Pump housing:                                    Ductile iron                          EN-GJS-400-18-LT                          ASTM Grade 60-40-18                      Impeller:    Bronze                          CuSn10-C</p> <p>Installation:                      Range of ambient temperature:            -20 .. 55 °C                      Maximum operating pressure:              25 bar                      Max pressure at stated temp:              25 bar / 120 °C                      Type of connection:                            DIN</p>

Qty.	Description
1	<p>Size of connection: DN 100            Pressure rating for connection: PN 25            Port-to-port length: 670 mm            Flange size for motor: FF600</p> <p>Electrical data:            Motor type: SIEMENS            Rated power - P2: 110 kW            Mains frequency: 50 Hz            Rated voltage: 3 x 380-420D/660-725Y V            Rated current: 184/107 A            Starting current: 910 %            Cos phi - power factor: 0.9            Rated speed: 2988 rpm            IE efficiency: IE4 96%            IE Efficiency class: IE4            Motor efficiency at full load: 96 %            Motor efficiency at 3/4 load: 95.9 %            Motor efficiency at 1/2 load: 95.1 %            Number of poles: 2            Enclosure class (IEC 34-5): IP55            Insulation class (IEC 85): F            Motor No: 92898768</p> <p>Others:            Minimum efficiency index, MEI ≥: 0.70            Net weight: 1220 kg            Gross weight: 1270 kg            Shipping volume: 2.14 m<sup>3</sup>            Country of origin: HU            Custom tariff no.: 84137051</p>

## On request TP 100-1040/2 A3-F-Y-DQQE-1W1 50 Hz

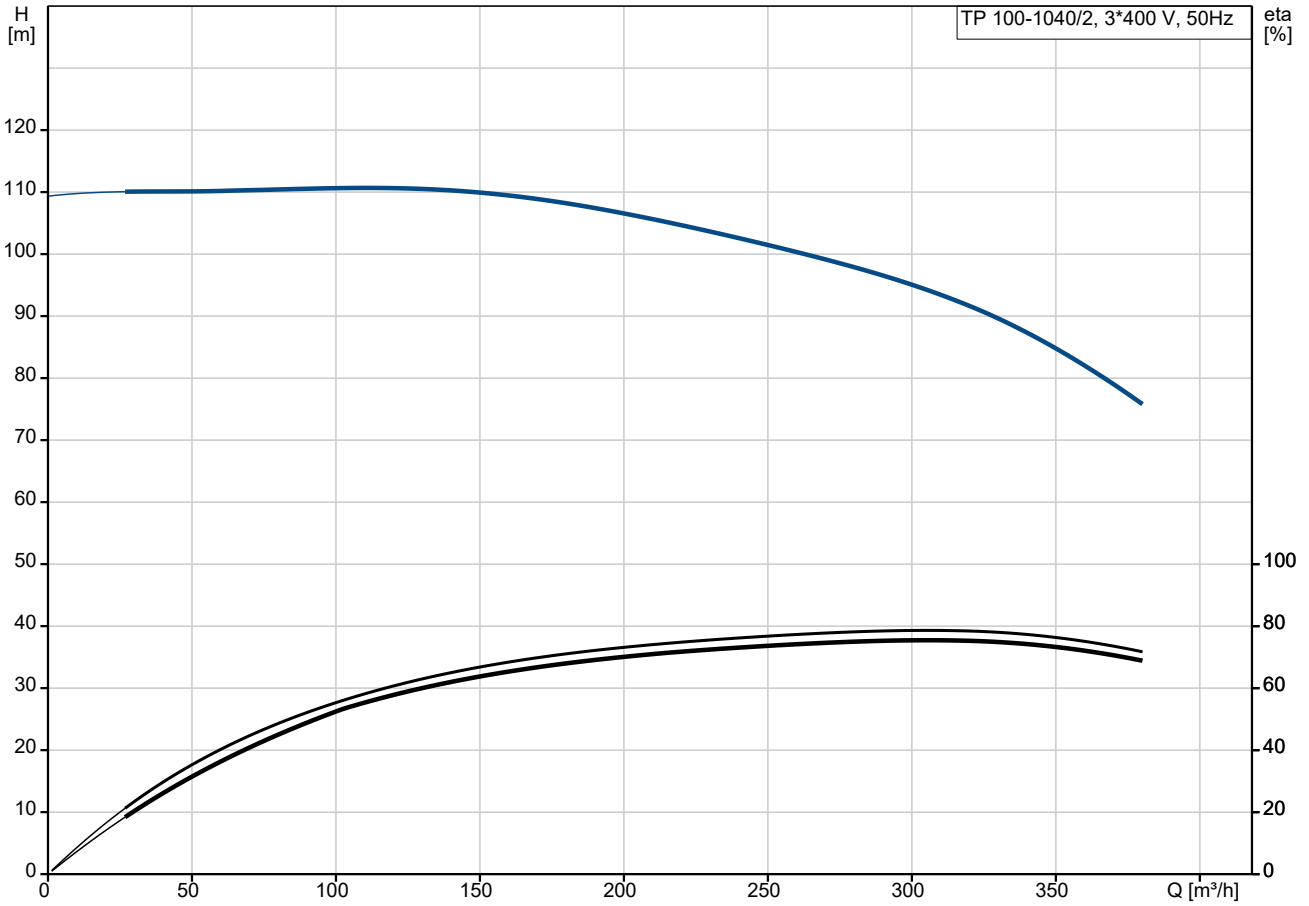

Pumped liquid = Water  
 Liquid temperature during operation = 20 °C  
 Density = 998.2 kg/m³

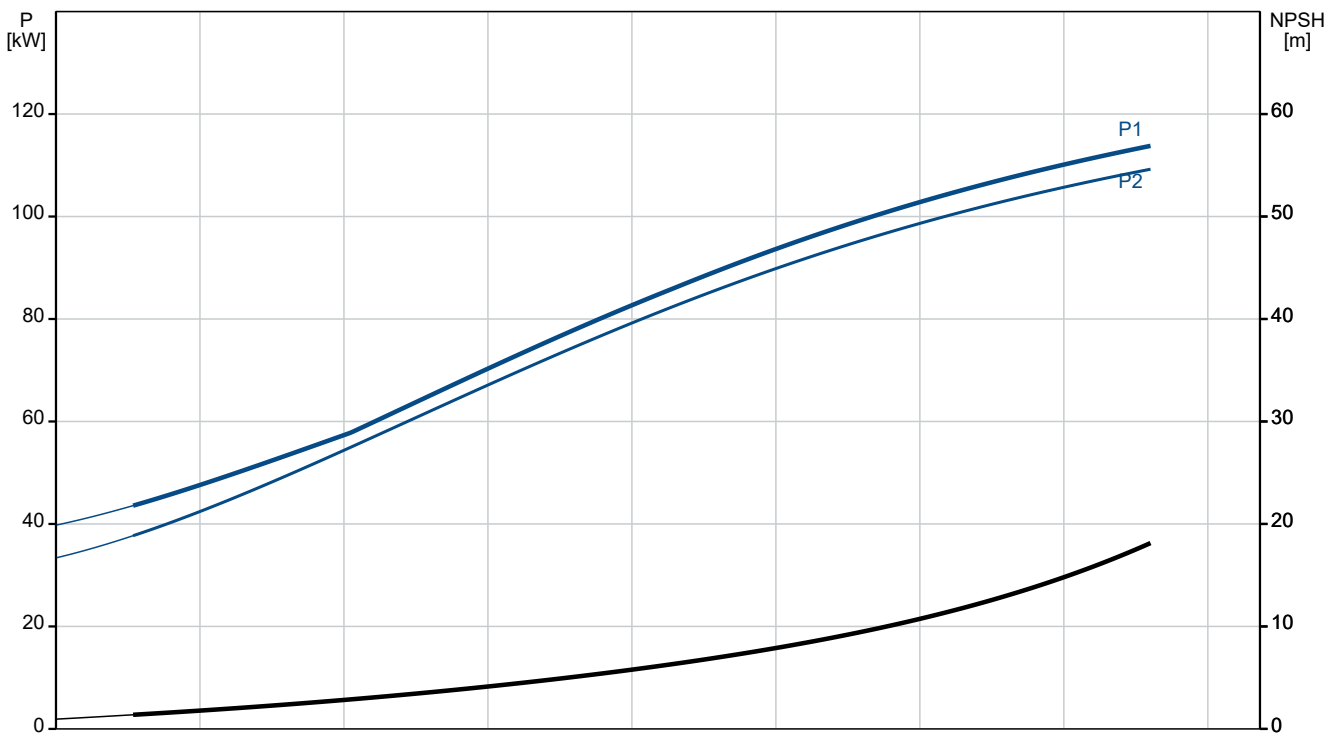

Description	Value
<b>General information:</b>	
Product name:	TP 100-1040/2 A3-F-Y-DQQE-1W1
Product No:	On request
EAN number:	On request
<b>Technical:</b>	
Pump speed on which pump data are based:	2984 rpm
Rated flow:	292 m <sup>3</sup> /h
Rated head:	95.98 m
Maximum head:	1040 dm
Actual impeller diameter:	284 mm
Code for shaft seal:	DQQE
Curve tolerance:	ISO9906:2012 3B
Pump version:	A3
<b>Materials:</b>	
Pump housing:	Ductile iron
Pump housing:	EN-GJS-400-18-LT
Pump housing:	ASTM Grade 60-40-18
Impeller:	Bronze
Impeller:	CuSn10-C
Material code:	Y
<b>Installation:</b>	
Range of ambient temperature:	-20 .. 55 °C
Maximum operating pressure:	25 bar
Max pressure at stated temp:	25 bar / 120 °C
Type of connection:	DIN
Size of connection:	DN 100
Pressure rating for connection:	PN 25
Port-to-port length:	670 mm
Flange size for motor:	FF600
Connect code:	F
<b>Liquid:</b>	
Liquid temperature range:	-40 .. 120 °C
<b>Electrical data:</b>	
Motor type:	SIEMENS
Rated power - P2:	110 kW
Mains frequency:	50 Hz
Rated voltage:	3 x 380-420D/660-725Y V
Rated current:	184/107 A
Starting current:	910 %
Cos phi - power factor:	0.9
Rated speed:	2988 rpm
IE efficiency:	IE4 96%
IE Efficiency class:	IE4
Motor efficiency at full load:	96 %
Motor efficiency at 3/4 load:	95.9 %
Motor efficiency at 1/2 load:	95.1 %
Number of poles:	2
Enclosure class (IEC 34-5):	IP55
Insulation class (IEC 85):	F
Built-in motor protection:	PTC
Motor No:	92898768
<b>Controls:</b>	
Frequency converter:	None
<b>Others:</b>	
Minimum efficiency index, MEI ≥:	0.70
Net weight:	1220 kg

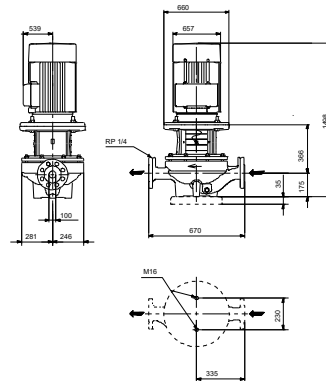
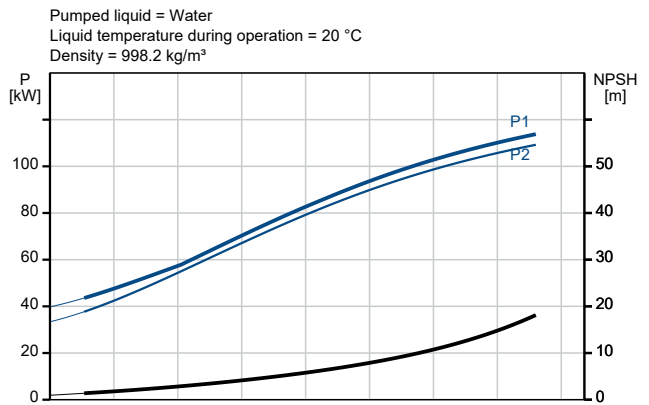
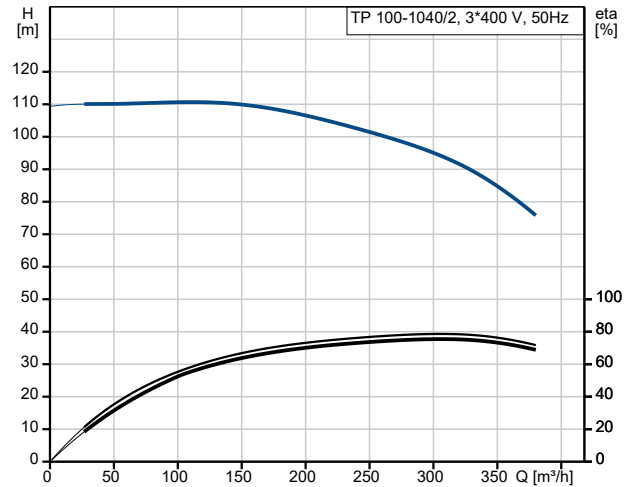



Company name:

Created by:

Phone:

Date:

02/12/2023

Description	Value
Gross weight:	1270 kg
Shipping volume:	2.14 m <sup>3</sup>
Country of origin:	HU
Custom tariff no.:	84137051

## On request TP 100-1040/2 A3-F-Y-DQQE-1W1 50 Hz

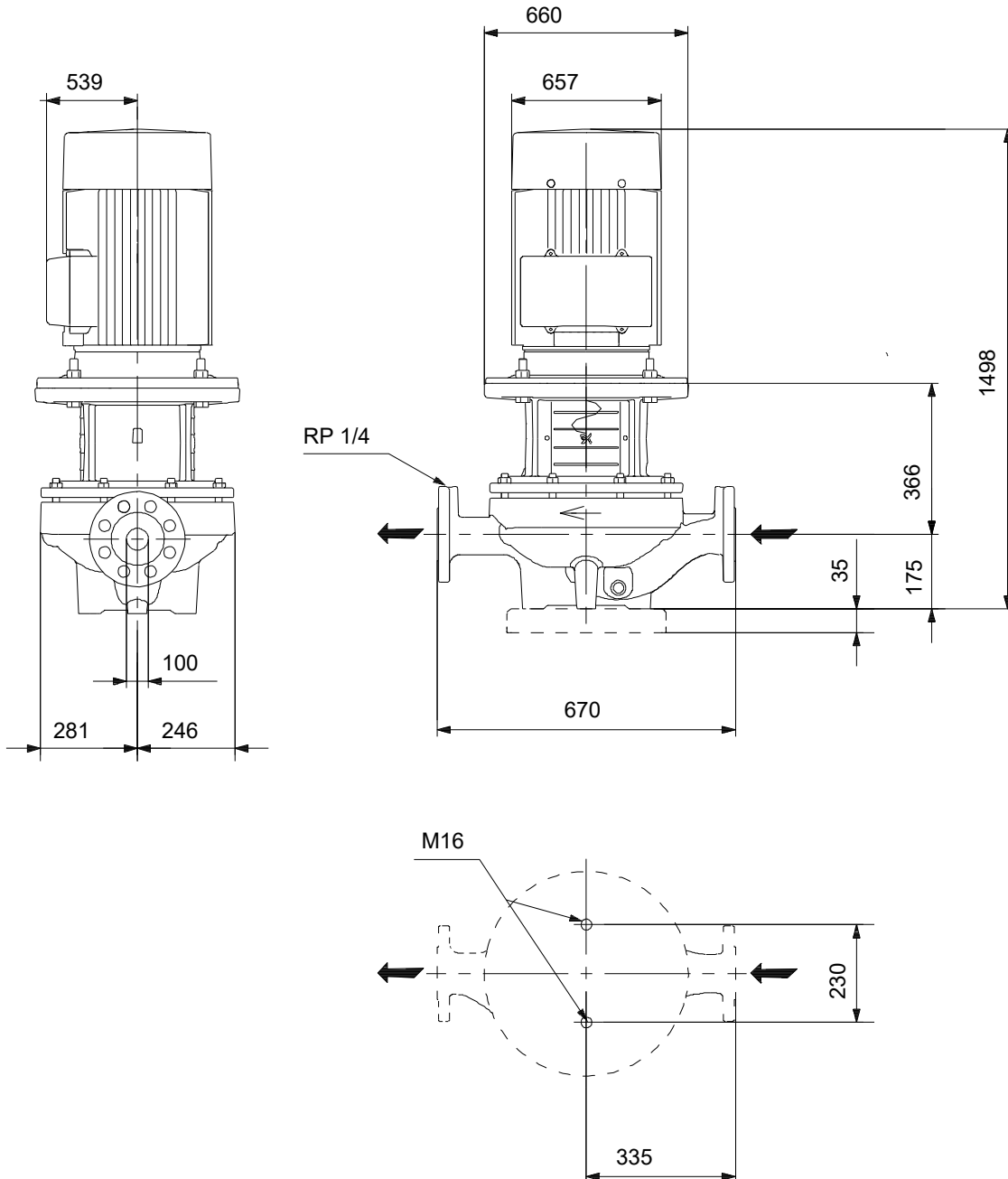

Note! All units are in [mm] unless others are stated.  
Disclaimer: This simplified dimensional drawing does not show all details.

