

# Submittal Data

PROJECT:	UNIT TAG:	QUANTITY:
REPRESENTATIVE: _____	TYPE OF SERVICE:	DATE: _____
ENGINEER:	SUBMITTED BY:	DATE:
CONTRACTOR:	APPROVED BY:	DATE:
	ORDER NO.:	DATE:



## TP 100-140/4 A3-F-Y-DQQE-LW3

Grundfos TP pumps are single-stage, close-coupled in-line centrifugal pumps with mechanical shaft seal and primely for applications such as heating/cooling/district energy. The pumps are fitted with fixed speed motors.

Note! Product picture may differ from actual product

Conditions of Service	Pump Data	Motor Data
	Max pressure at stated temp: 25 bar / 120 °C Liquid temperature range: -40 .. 120 °C Maximum ambient temperature: 55 °C Shaft seal: DQQE Product number: On request	Rated voltage: 220-240D/380-420Y V Mains frequency: 50 Hz Enclosure class: IP55 Insulation class: F Motor protection: PTC Motor type: SIEMENS Eta 1/1: 89.6-89.6 %

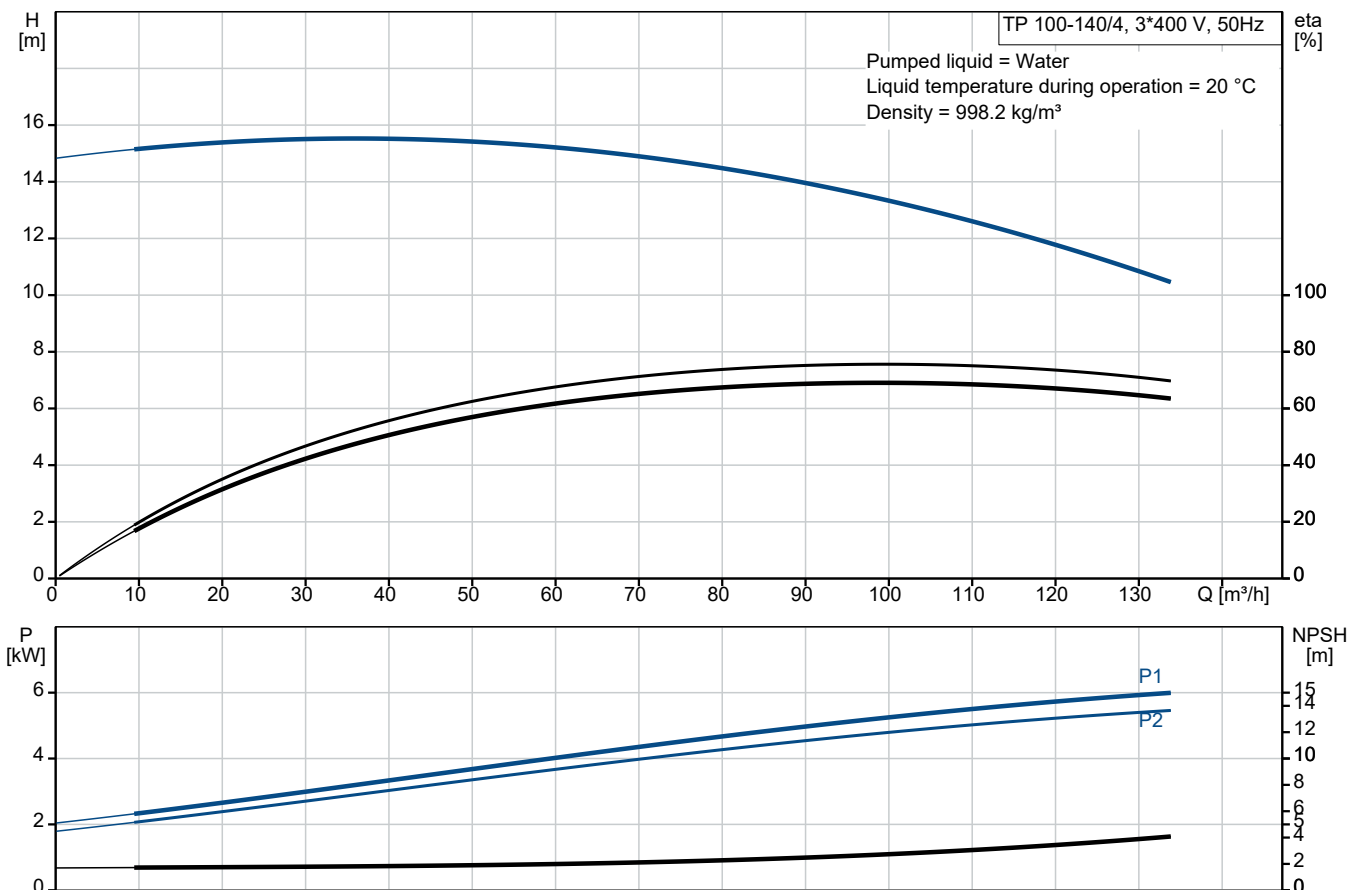

# Submittal Data

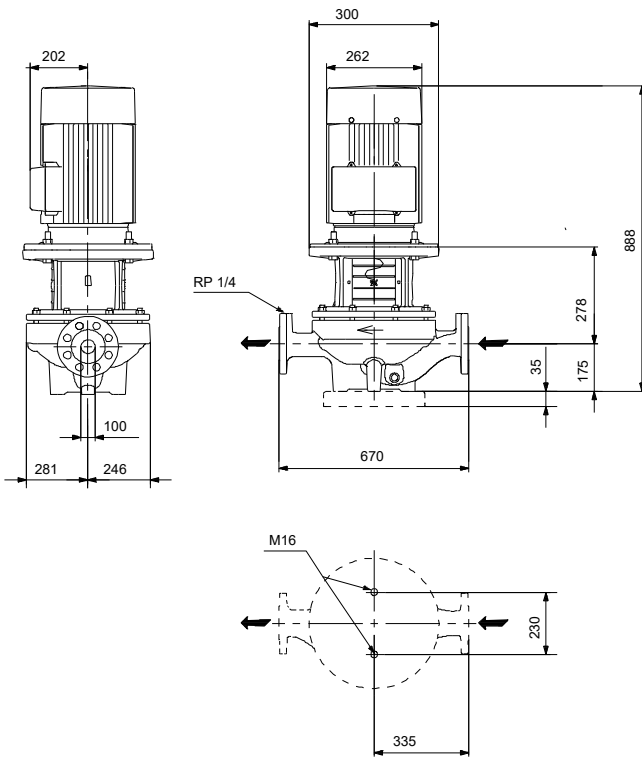

## Materials:

Pump housing: Ductile iron  
Pump housing: ASTM Grade 60-40-18  
Impeller: Bronze  
Impeller: CuSn10-C  
Material code: Y

**Qty. Description**

1 TP 100-140/4 A3-F-Y-DQQE-LW3



**Note! Product picture may differ from actual product**

Product No.: On request

Single-stage, close-coupled, volute pump with in-line suction and discharge ports of identical diameter. The pump is of the top-pull-out design, i.e. the power head (motor, pump head and impeller) can be removed for maintenance or service while the pump housing remains in the pipework.

The pump is fitted with a balanced O-ring seal. The shaft seal is according to EN 12756. Pipework connection is via PN 25 DIN flanges (EN 1092-2 and ISO 7005-2).

The pump is fitted with a fan-cooled asynchronous motor.

The product's minimum efficiency index (MEI) is greater or equal to 0.70. This is by the Commission Regulation (EU) considered as an indicative benchmark for best-performing water pump available on the market as from 1 January 2013.

Cast-iron parts have an epoxy-based coating made in a cathodic electro-deposition (CED) process. CED is a high-quality dip-painting process where an electrical field around the products ensures deposition of paint particles as a thin, well-controlled layer on the surface.

**Pump**

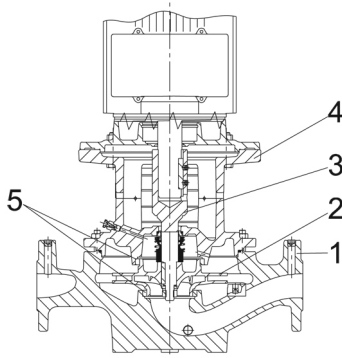

1: Pump housing

2: Impeller

3: Stub shaft

4: Pump head/motor stool

5: Wear rings

The pump housing is provided with a replaceable brass neck ring to reduce the amount of liquid running from the outlet side of the impeller to the inlet side.

The impeller is secured to the shaft with a nut.

The pump is fitted with a balanced O-ring seal. Due to the balancing, this seal type is suitable for high-pressure applications. This seal type is excellent for high-viscosity, dirt- and fibre-containing liquids due to the spring location on the atmospheric side. The seal features a rigid torque-transmission design.

Seal faces:

- Rotating seal ring material: silicon carbide (SiC)
- Stationary seat material: silicon carbide (SiC)

This material pairing is used where higher corrosion resistance is required. The high hardness of this material pairing offers good resistance against abrasive particles.

Secondary seal material: EPDM (ethylene-propylene rubber)

Qty.	Description
1	<p>EPDM has excellent resistance to hot water. EPDM is not suitable for mineral oils.                      A circulation of liquid through the duct of the air vent screw ensures lubrication and cooling of the shaft seal.                      The flanges have tappings for mounting of pressure gauges.                      The motor stool forms connection between the pump housing and the motor, and is equipped with a manual air vent screw for venting of the pump housing and the shaft seal chamber. The sealing between motor stool and pump housing is an O-ring.                      The central part of the motor stool is provided with guards for protection against the shaft and coupling. The pump shaft is fastened directly on the motor shaft with key and set screws.                      The pump is mounted with a base plate.</p> <p><b>Motor</b>                      The motor is a totally enclosed, fan-cooled motor with principal dimensions to IEC and DIN standards. Electrical tolerances comply with IEC 60034.                      The motor is flange-mounted with free-hole flange (FF).                      Motor-mounting designation in accordance with IEC 60034-7: IM B 5, IM V 1 (Code I) / IM 3001, IM 3011 (Code II).                      The motor efficiency is classified as IE3 in accordance with IEC 60034-30-1.                      The motor has thermistors (PTC sensors) in the windings in accordance with DIN 44081/DIN 44082. The protection reacts to both slow- and quick-rising temperatures, e.g. constant overload and stalled conditions.                      Thermal switches must be connected to an external control circuit in a way which ensures that the automatic reset cannot cause accidents. The motors must be connected to a motor-protective circuit breaker according to local regulations.                      The motor can be connected to a variable speed drive for adjustment of pump performance to any duty point. Grundfos CUE offers a range of variable speed drives. Please find more information in Grundfos Product Center.</p> <p><b>Further product details</b>                      Cast-iron parts have an epoxy-based coating made in a cathodic electro-deposition (CED) process. CED is a high-quality dip-painting process where an electrical field around the products ensures deposition of paint particles as a thin, well-controlled layer on the surface.</p> <p><b>Technical data</b></p> <p>Controls:                      Frequency converter:                      None</p> <p>Liquid:                      Liquid temperature range:                -40 .. 120 °C</p> <p>Technical:                      Pump speed on which pump data are based:    1460 rpm                      Rated flow:                                      102 m³/h                      Rated head:                                      12.91 m                      Actual impeller diameter:                    215 mm                      Code for shaft seal:                          DQQE                      Curve tolerance:                                ISO9906:2012 3B2</p> <p>Materials:                      Pump housing:                                    Ductile iron                          EN-GJS-400-18-LT                          ASTM Grade 60-40-18                      Impeller:    Bronze                          CuSn10-C</p> <p>Installation:                      Range of ambient temperature:            -20 .. 55 °C                      Maximum operating pressure:              25 bar                      Max pressure at stated temp:              25 bar / 120 °C                      Type of connection:                          DIN</p>

**Qty. Description**

1	Size of connection:	DN 100
	Pressure rating for connection:	PN 25
	Port-to-port length:	670 mm
	Flange size for motor:	FF265
	Electrical data:	
	Motor type:	SIEMENS
	Rated power - P2:	5.5 kW
	Mains frequency:	50 Hz
	Rated voltage:	3 x 220-240D/380-420Y V
	Rated current:	18.8/10.8 A
	Starting current:	850-850 %
	Cos phi - power factor:	0.82
	Rated speed:	1470 rpm
	IE efficiency:	IE3 89,6%
	IE Efficiency class:	IE3
	Motor efficiency at full load:	89.6-89.6 %
	Motor efficiency at 3/4 load:	90-90 %
	Motor efficiency at 1/2 load:	89.5-89.5 %
	Number of poles:	4
	Enclosure class (IEC 34-5):	IP55
	Insulation class (IEC 85):	F
	Motor No:	83V05217
	Others:	
	Minimum efficiency index, MEI ≥:	0.70
	Net weight:	228 kg
	Gross weight:	264 kg
	Shipping volume:	0.743 m <sup>3</sup>
	Country of origin:	HU
	Custom tariff no.:	84137051

## On request TP 100-140/4 A3-F-Y-DQQE-LW3 50 Hz

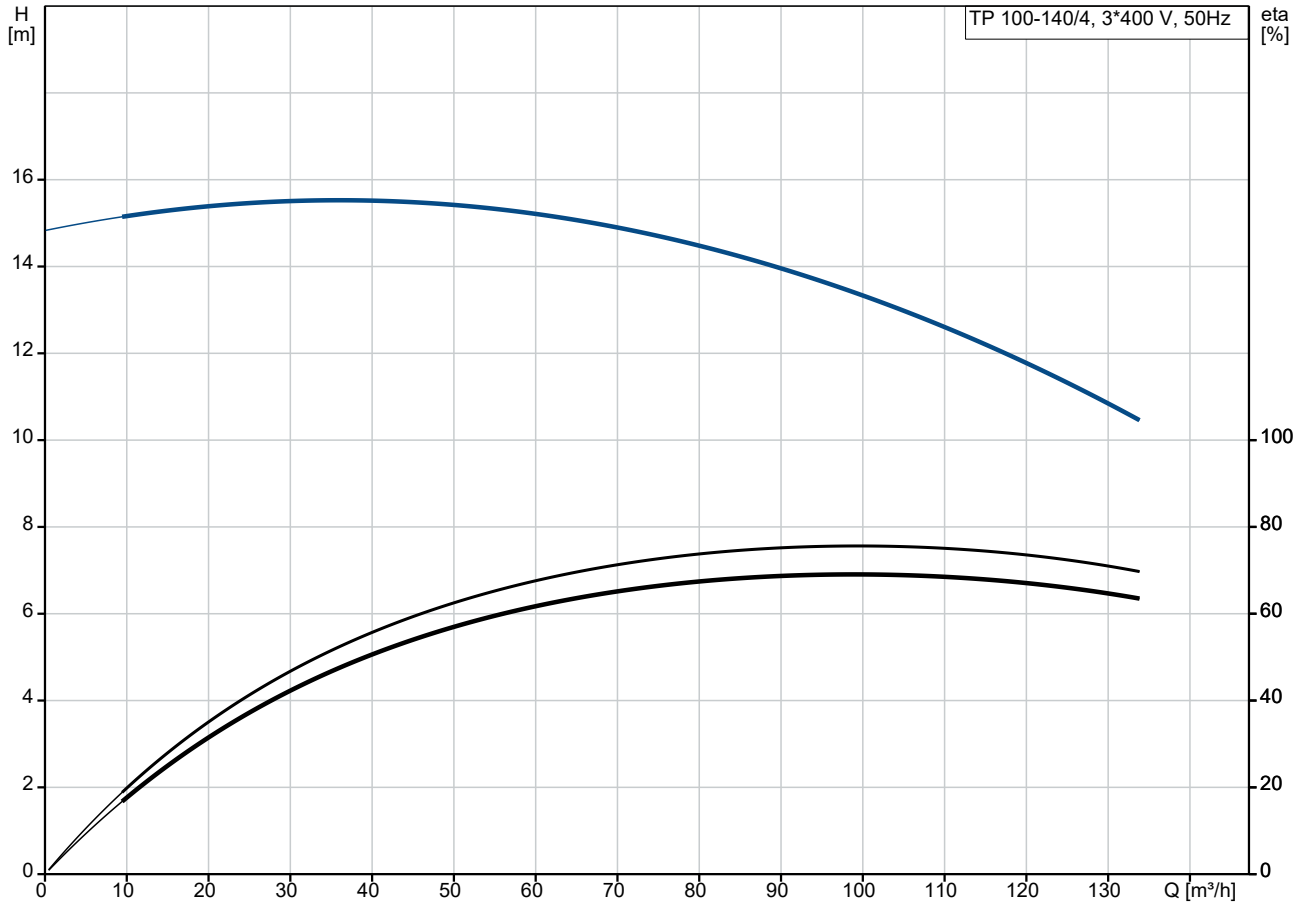

Pumped liquid = Water  
 Liquid temperature during operation = 20 °C  
 Density = 998.2 kg/m³

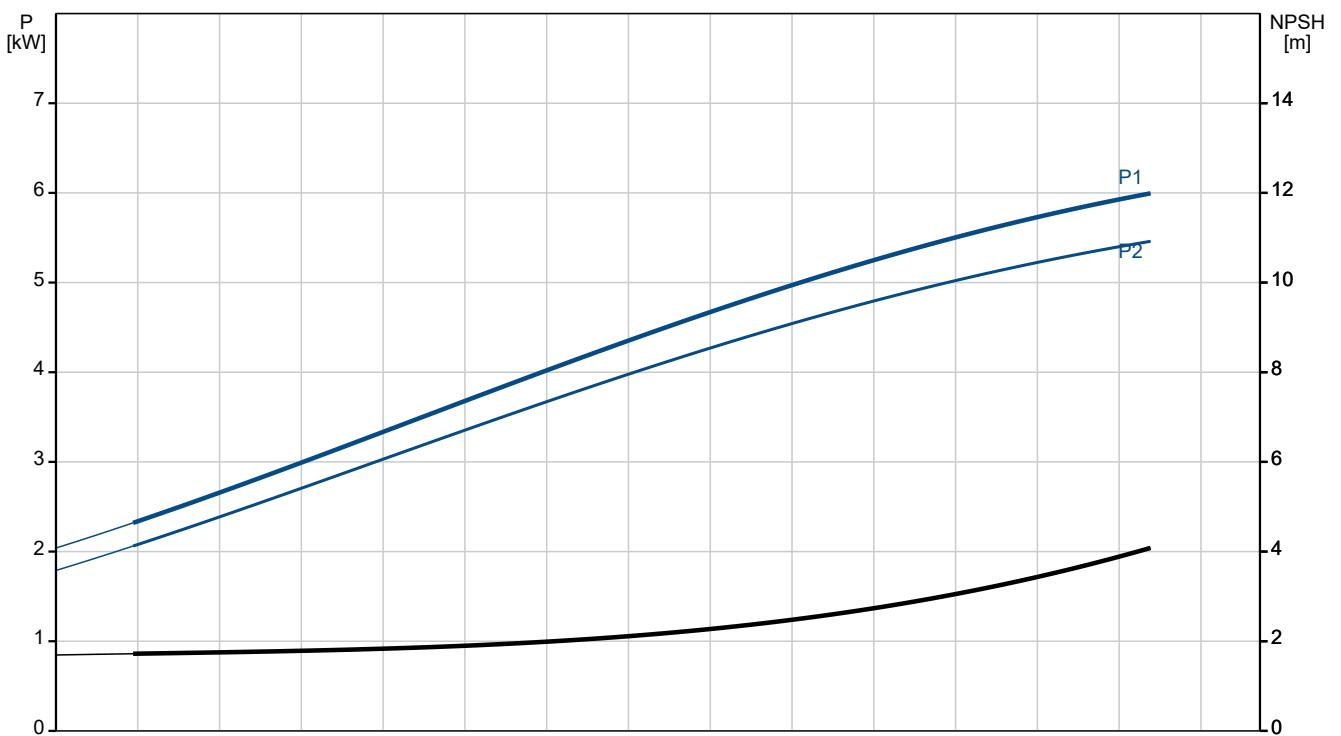

Description	Value
<b>General information:</b>	
Product name:	TP 100-140/4 A3-F-Y-DQQE-LW3
Product No:	On request
EAN number:	On request
<b>Technical:</b>	
Pump speed on which pump data are based:	1460 rpm
Rated flow:	102 m <sup>3</sup> /h
Rated head:	12.91 m
Maximum head:	140 dm
Actual impeller diameter:	215 mm
Code for shaft seal:	DQQE
Curve tolerance:	ISO9906:2012 3B2
Pump version:	A3
<b>Materials:</b>	
Pump housing:	Ductile iron
Pump housing:	EN-GJS-400-18-LT
Pump housing:	ASTM Grade 60-40-18
Impeller:	Bronze
Impeller:	CuSn10-C
Material code:	Y
<b>Installation:</b>	
Range of ambient temperature:	-20 .. 55 °C
Maximum operating pressure:	25 bar
Max pressure at stated temp:	25 bar / 120 °C
Type of connection:	DIN
Size of connection:	DN 100
Pressure rating for connection:	PN 25
Port-to-port length:	670 mm
Flange size for motor:	FF265
Connect code:	F
<b>Liquid:</b>	
Liquid temperature range:	-40 .. 120 °C
<b>Electrical data:</b>	
Motor type:	SIEMENS
Rated power - P2:	5.5 kW
Mains frequency:	50 Hz
Rated voltage:	3 x 220-240D/380-420Y V
Rated current:	18.8/10.8 A
Starting current:	850-850 %
Cos phi - power factor:	0.82
Rated speed:	1470 rpm
IE efficiency:	IE3 89,6%
IE Efficiency class:	IE3
Motor efficiency at full load:	89.6-89.6 %
Motor efficiency at 3/4 load:	90-90 %
Motor efficiency at 1/2 load:	89.5-89.5 %
Number of poles:	4
Enclosure class (IEC 34-5):	IP55
Insulation class (IEC 85):	F
Built-in motor protection:	PTC
Motor No:	83V05217
<b>Controls:</b>	
Frequency converter:	None
<b>Others:</b>	
Minimum efficiency index, MEI ≥:	0.70
Net weight:	228 kg

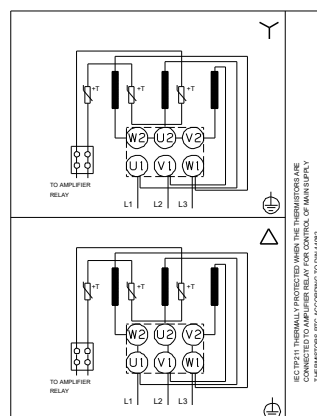
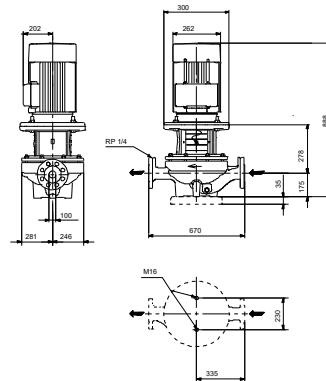
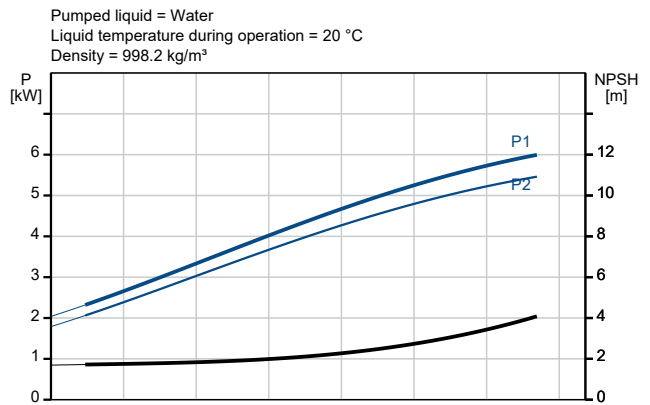
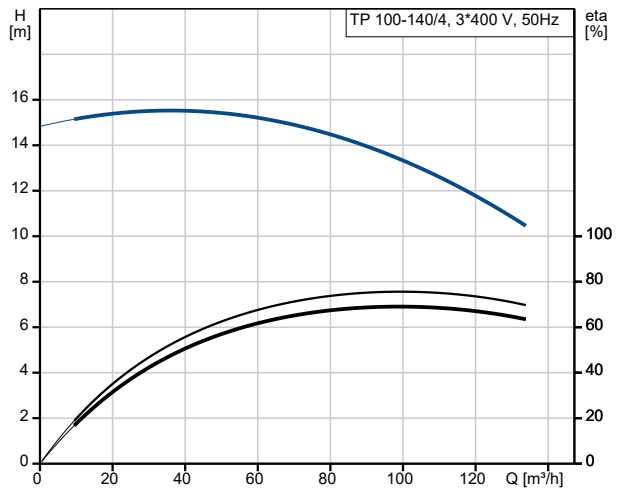



Company name:

Created by:

Phone:

Date:

01/12/2023

Description	Value
Gross weight:	264 kg
Shipping volume:	0.743 m <sup>3</sup>
Country of origin:	HU
Custom tariff no.:	84137051

## On request TP 100-140/4 A3-F-Y-DQQE-LW3 50 Hz

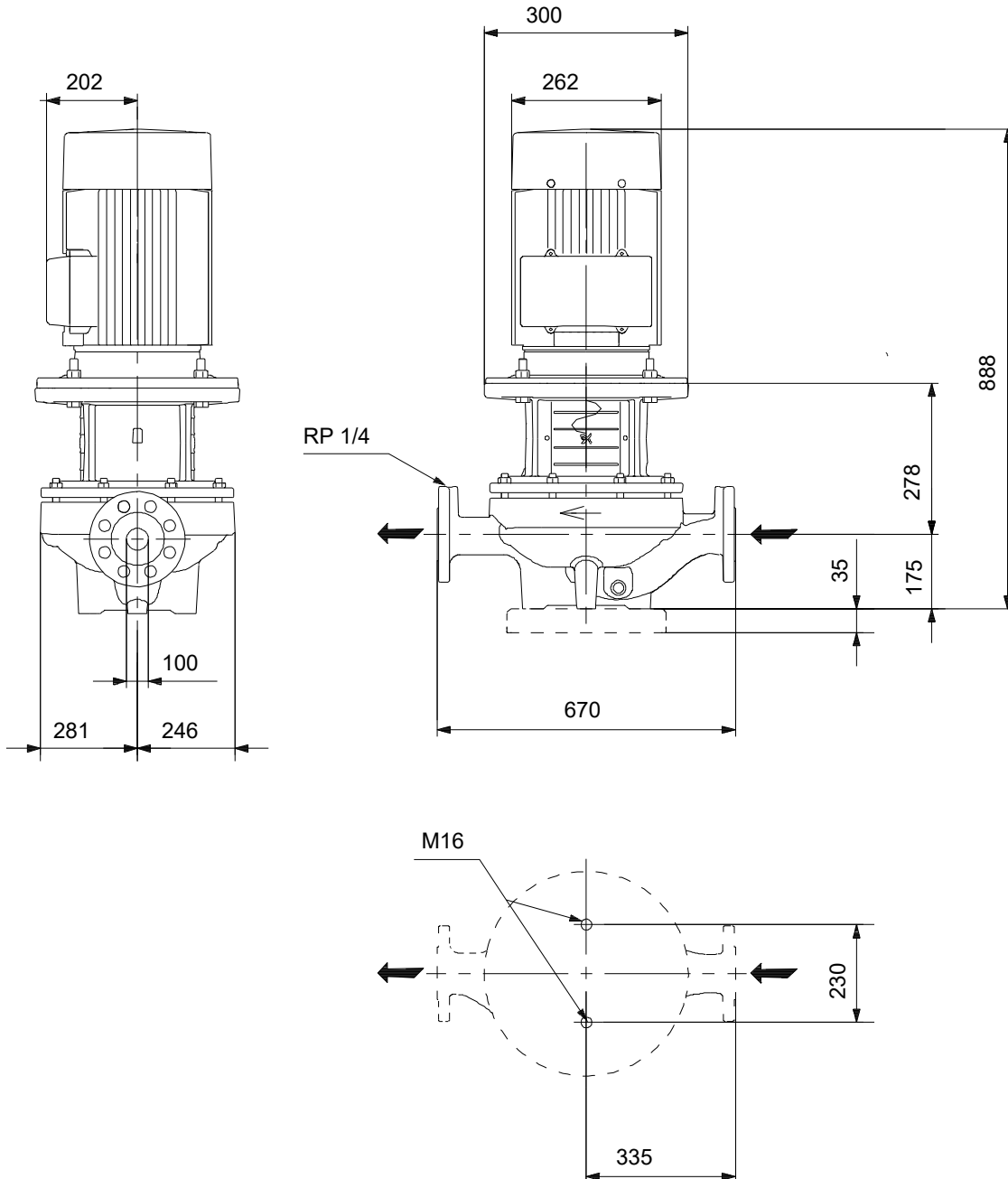

Note! All units are in [mm] unless others are stated.  
Disclaimer: This simplified dimensional drawing does not show all details.

## On request TP 100-140/4 A3-F-Y-DQQE-LW3 50 Hz



IEC TP211 THERMALLY PROTECTED WHEN THE THERMISTORS ARE  
CONNECTED TO AMPLIFIER RELAY FOR CONTROL OF MAIN SUPPLY  
THERMISTORS PTC ACCORDING TO DIN 44082

Note! All units are in [mm] unless others are stated.

