

Submittal Data

PROJECT:	UNIT TAG:	QUANTITY:
REPRESENTATIVE: _____	TYPE OF SERVICE:	DATE: _____
ENGINEER:	SUBMITTED BY:	DATE:
CONTRACTOR:	APPROVED BY:	DATE:
	ORDER NO.:	DATE:



TP 100-250/4 A3-F-O-DAQF-NW3

Grundfos TP pumps are single-stage, close-coupled in-line centrifugal pumps with mechanical shaft seal and primely for applications such as heating/cooling/district energy. The pumps are fitted with fixed speed motors.

Note! Product picture may differ from actual product

Conditions of Service	Pump Data	Motor Data
	Max pressure at stated temp: 25 bar / 140 °C Liquid temperature range: 0 .. 140 °C Maximum ambient temperature: 55 °C Shaft seal: DAQF Product number: On request	Rated voltage: 220-240D/380-420Y V Mains frequency: 50 Hz Enclosure class: IP55 Insulation class: F Motor protection: PTC Motor type: SIEMENS Eta 1/1: 91.4-91.4 %

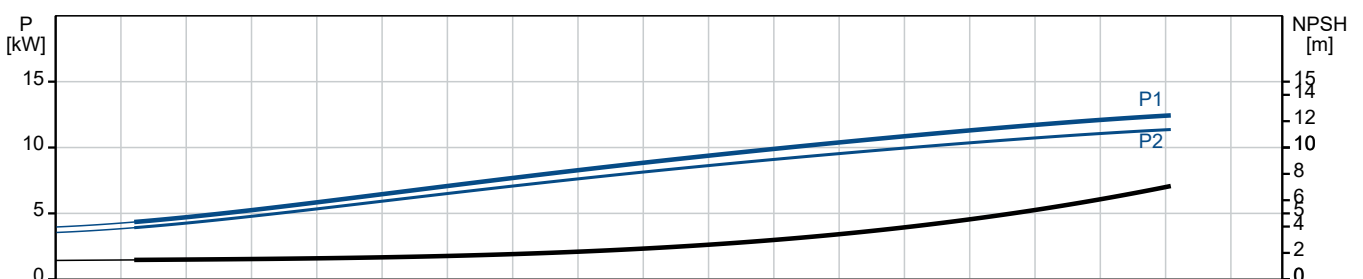
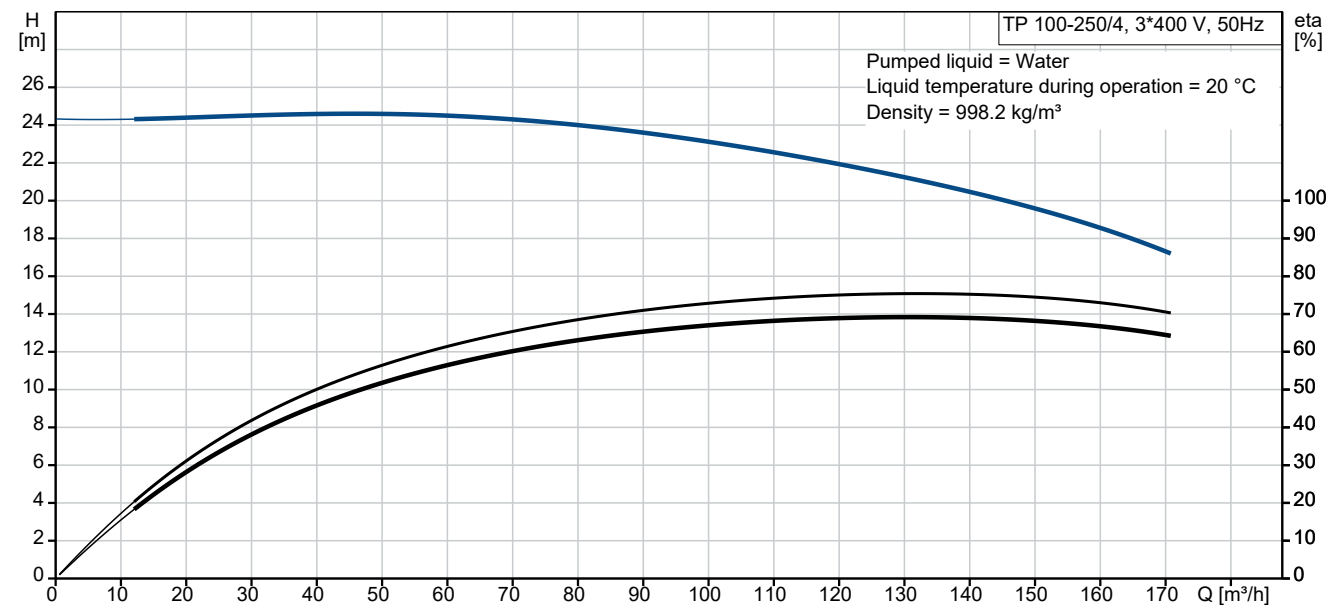

Submittal Data

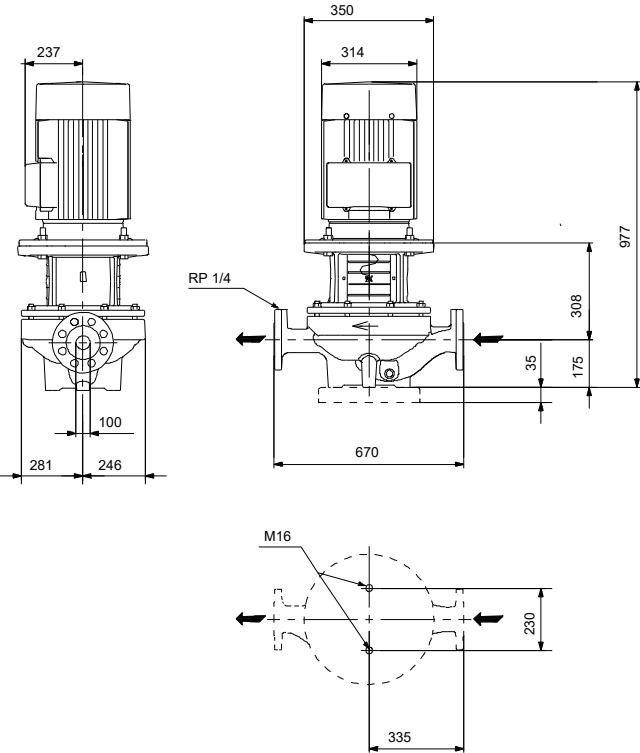

Materials:
 Pump housing: Ductile iron
 Pump housing: ASTM Grade 60-40-18
 Impeller: Cast iron
 Impeller: ASTM class 30
 Impeller: EN-GJL-200
 Material code: O

Qty. Description

1 TP 100-250/4 A3-F-O-DAQF-NW3



Note! Product picture may differ from actual product

Product No.: On request

Single-stage, close-coupled, volute pump with in-line suction and discharge ports of identical diameter. The pump is of the top-pull-out design, i.e. the power head (motor, pump head and impeller) can be removed for maintenance or service while the pump housing remains in the pipework.

The pump is fitted with a balanced O-ring seal. The shaft seal is according to EN 12756. Pipework connection is via PN 25 DIN flanges (EN 1092-2 and ISO 7005-2).

The pump is fitted with a fan-cooled asynchronous motor.

Cast-iron parts have an epoxy-based coating made in a cathodic electro-deposition (CED) process. CED is a high-quality dip-painting process where an electrical field around the products ensures deposition of paint particles as a thin, well-controlled layer on the surface.

Pump



- 1: Pump housing
- 2: Impeller
- 3: Stub shaft
- 4: Pump head/motor stool
- 5: Wear rings

The pump housing is provided with a replaceable brass neck ring to reduce the amount of liquid running from the outlet side of the impeller to the inlet side.

The impeller is secured to the shaft with a nut.

The pump is fitted with a balanced O-ring seal. Due to the balancing, this seal type is suitable for high-pressure applications. This seal type is excellent for high-viscosity, dirt- and fibre-containing liquids due to the spring location on the atmospheric side. The seal features a rigid torque-transmission design.

Seal faces:

- Rotating seal ring material: carbon graphite, metal-impregnated
- Stationary seat material: silicon carbide (SiC)

Due to the favourable lubricating properties of carbon graphite, the seal is suitable for use even under poor lubricating conditions, such as hot water.

However, under such conditions, wear on the carbon graphite face can be expected, and seal life will be reduced .

The material pairing is not recommended for liquids containing particles as this will result in wear on the SiC face.
Secondary seal material: FXM (fluorinated copolymer)

Qty.	Description
1	<p data-bbox="201 338 1414 371">FXM is particularly suitable for extremely high temperatures and pressures. FXM has a good chemical resistance.</p> <p data-bbox="201 398 1353 432">A circulation of liquid through the duct of the air vent screw ensures lubrication and cooling of the shaft seal.</p> <p data-bbox="201 432 847 465">The flanges have tappings for mounting of pressure gauges.</p> <p data-bbox="201 465 1442 539">The motor stool forms connection between the pump housing and the motor, and is equipped with a manual air vent screw for venting of the pump housing and the shaft seal chamber. The sealing between motor stool and pump housing is an O-ring.</p> <p data-bbox="201 544 1417 600">The central part of the motor stool is provided with guards for protection against the shaft and coupling. The pump shaft is fastened directly on the motor shaft with key and set screws.</p> <p data-bbox="201 600 632 633">The pump is mounted with a base plate.</p> <p data-bbox="201 660 284 694">Motor</p> <p data-bbox="201 694 1394 750">The motor is a totally enclosed, fan-cooled motor with principal dimensions to IEC and DIN standards. Electrical tolerances comply with IEC 60034.</p> <p data-bbox="201 750 794 784">The motor is flange-mounted with free-hole flange (FF).</p> <p data-bbox="201 784 1426 817">Motor-mounting designation in accordance with IEC 60034-7: IM B 5, IM V 1 (Code I) / IM 3001, IM 3011 (Code II).</p> <p data-bbox="201 844 1015 878">The motor efficiency is classified as IE3 in accordance with IEC 60034-30-1.</p> <p data-bbox="201 878 1433 934">The motor has thermistors (PTC sensors) in the windings in accordance with DIN 44081/DIN 44082. The protection reacts to both slow- and quick-rising temperatures, e.g. constant overload and stalled conditions.</p> <p data-bbox="201 934 1422 1008">Thermal switches must be connected to an external control circuit in a way which ensures that the automatic reset cannot cause accidents. The motors must be connected to a motor-protective circuit breaker according to local regulations.</p> <p data-bbox="201 1012 1406 1068">The motor can be connected to a variable speed drive for adjustment of pump performance to any duty point. Grundfos CUE offers a range of variable speed drives. Please find more information in Grundfos Product Center.</p> <p data-bbox="201 1104 512 1137">Further product details</p> <p data-bbox="201 1137 1453 1211">Cast-iron parts have an epoxy-based coating made in a cathodic electro-deposition (CED) process. CED is a high-quality dip-painting process where an electrical field around the products ensures deposition of paint particles as a thin, well-controlled layer on the surface.</p> <p data-bbox="201 1283 400 1317">Technical data</p> <p data-bbox="201 1350 300 1384">Controls:</p> <p data-bbox="201 1384 624 1417">Frequency converter: None</p> <p data-bbox="201 1444 276 1478">Liquid:</p> <p data-bbox="201 1478 683 1512">Liquid temperature range: 0 .. 140 °C</p> <p data-bbox="201 1538 316 1572">Technical:</p> <p data-bbox="201 1572 820 1606">Pump speed on which pump data are based: 1460 rpm</p> <p data-bbox="201 1606 663 1639">Rated flow: 131 m³/h</p> <p data-bbox="201 1639 639 1673">Rated head: 20.7 m</p> <p data-bbox="201 1673 655 1706">Actual impeller diameter: 270 mm</p> <p data-bbox="201 1706 635 1740">Code for shaft seal: DAQF</p> <p data-bbox="201 1740 759 1774">Curve tolerance: ISO9906:2012 3B</p> <p data-bbox="201 1800 309 1834">Materials:</p> <p data-bbox="201 1834 812 1908">Pump housing: Ductile iron EN-GJS-400-18-LT ASTM Grade 60-40-18</p> <p data-bbox="201 1908 730 2004">Impeller: Cast iron EN-GJL-200 ASTM class 30</p> <p data-bbox="201 2031 325 2065">Installation:</p> <p data-bbox="201 2065 691 2098">Range of ambient temperature: -20 .. 55 °C</p> <p data-bbox="201 2098 635 2132">Maximum operating pressure: 25 bar</p>

Qty.	Description
1	<p>Max pressure at stated temp: 25 bar / 140 °C Type of connection: DIN Size of connection: DN 100 Pressure rating for connection: PN 25 Port-to-port length: 670 mm Flange size for motor: FF300</p> <p>Electrical data: Motor type: SIEMENS Rated power - P2: 11 kW Mains frequency: 50 Hz Rated voltage: 3 x 220-240D/380-420Y V Rated current: 36/20.5 A Starting current: 680-680 % Cos phi - power factor: 0.84 Rated speed: 1475 rpm IE efficiency: IE3 91,4% IE Efficiency class: IE3 Motor efficiency at full load: 91.4-91.4 % Motor efficiency at 3/4 load: 91.9-91.9 % Motor efficiency at 1/2 load: 91.4-91.4 % Number of poles: 4 Enclosure class (IEC 34-5): IP55 Insulation class (IEC 85): F Motor No: 83V05224</p> <p>Others: Minimum efficiency index, MEI ≥: 0.45 Net weight: 253 kg Gross weight: 290 kg Shipping volume: 0.743 m³ Country of origin: HU Custom tariff no.: 84137051</p>

On request TP 100-250/4 A3-F-O-DAQF-NW3 50 Hz

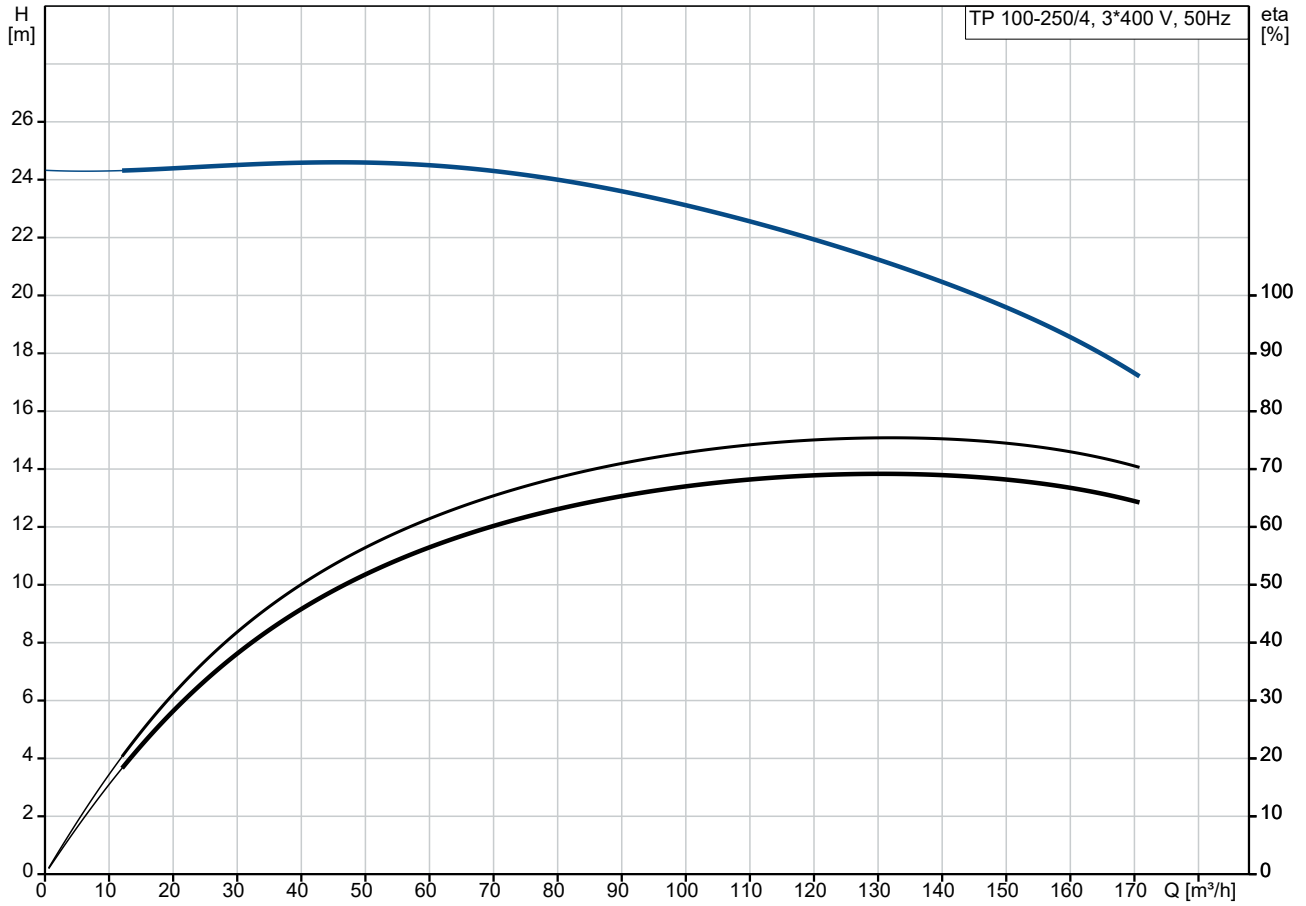

Pumped liquid = Water
 Liquid temperature during operation = 20 °C
 Density = 998.2 kg/m³

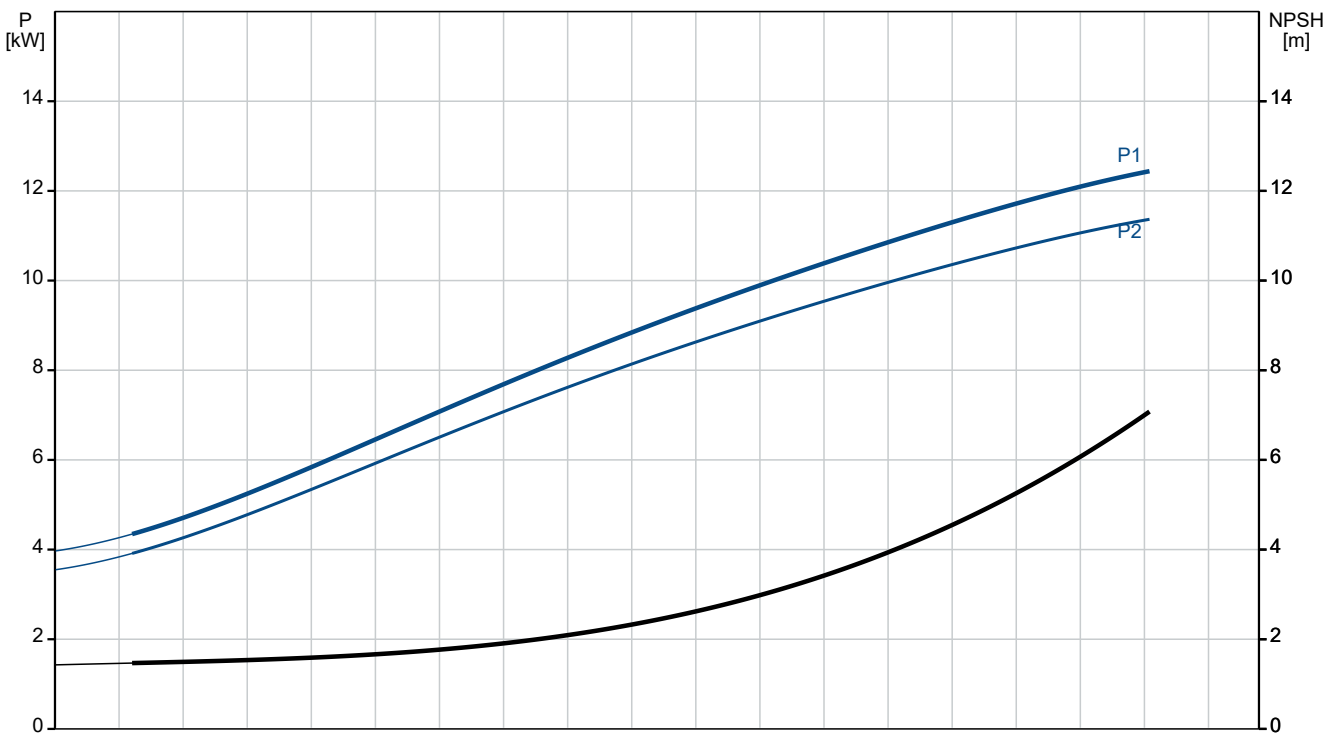

Description	Value
General information:	
Product name:	TP 100-250/4 A3-F-O-DAQF-NW3
Product No:	On request
EAN number:	On request
Technical:	
Pump speed on which pump data are based:	1460 rpm
Rated flow:	131 m ³ /h
Rated head:	20.7 m
Maximum head:	250 dm
Actual impeller diameter:	270 mm
Code for shaft seal:	DAQF
Curve tolerance:	ISO9906:2012 3B
Pump version:	A3
Materials:	
Pump housing:	Ductile iron
Pump housing:	EN-GJS-400-18-LT
Pump housing:	ASTM Grade 60-40-18
Impeller:	Cast iron
Impeller:	EN-GJL-200
Impeller:	ASTM class 30
Material code:	O
Installation:	
Range of ambient temperature:	-20 .. 55 °C
Maximum operating pressure:	25 bar
Max pressure at stated temp:	25 bar / 140 °C
Type of connection:	DIN
Size of connection:	DN 100
Pressure rating for connection:	PN 25
Port-to-port length:	670 mm
Flange size for motor:	FF300
Connect code:	F
Liquid:	
Liquid temperature range:	0 .. 140 °C
Electrical data:	
Motor type:	SIEMENS
Rated power - P2:	11 kW
Mains frequency:	50 Hz
Rated voltage:	3 x 220-240D/380-420Y V
Rated current:	36/20.5 A
Starting current:	680-680 %
Cos phi - power factor:	0.84
Rated speed:	1475 rpm
IE efficiency:	IE3 91,4%
IE Efficiency class:	IE3
Motor efficiency at full load:	91.4-91.4 %
Motor efficiency at 3/4 load:	91.9-91.9 %
Motor efficiency at 1/2 load:	91.4-91.4 %
Number of poles:	4
Enclosure class (IEC 34-5):	IP55
Insulation class (IEC 85):	F
Built-in motor protection:	PTC
Motor No:	83V05224
Controls:	
Frequency converter:	None
Others:	
Minimum efficiency index, MEI ≥:	0.45

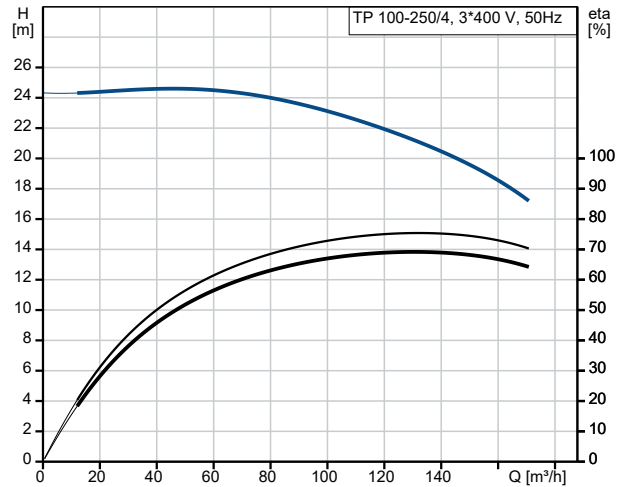

Pumped liquid = Water
 Liquid temperature during operation = 20 °C
 Density = 998.2 kg/m³

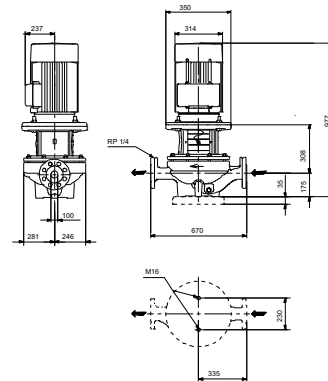
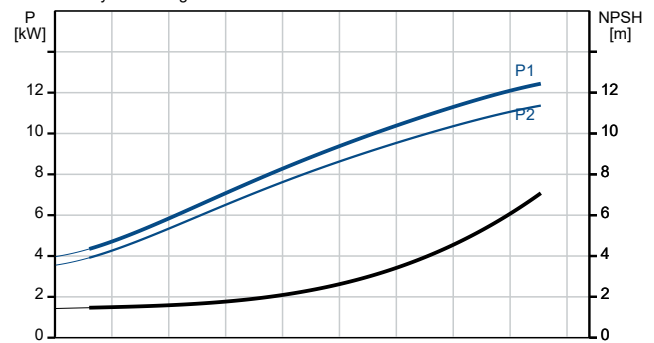



Company name:

Created by:

Phone:

Date:

02/12/2023

Description	Value
Net weight:	253 kg
Gross weight:	290 kg
Shipping volume:	0.743 m ³
Country of origin:	HU
Custom tariff no.:	84137051

On request TP 100-250/4 A3-F-O-DAQF-NW3 50 Hz

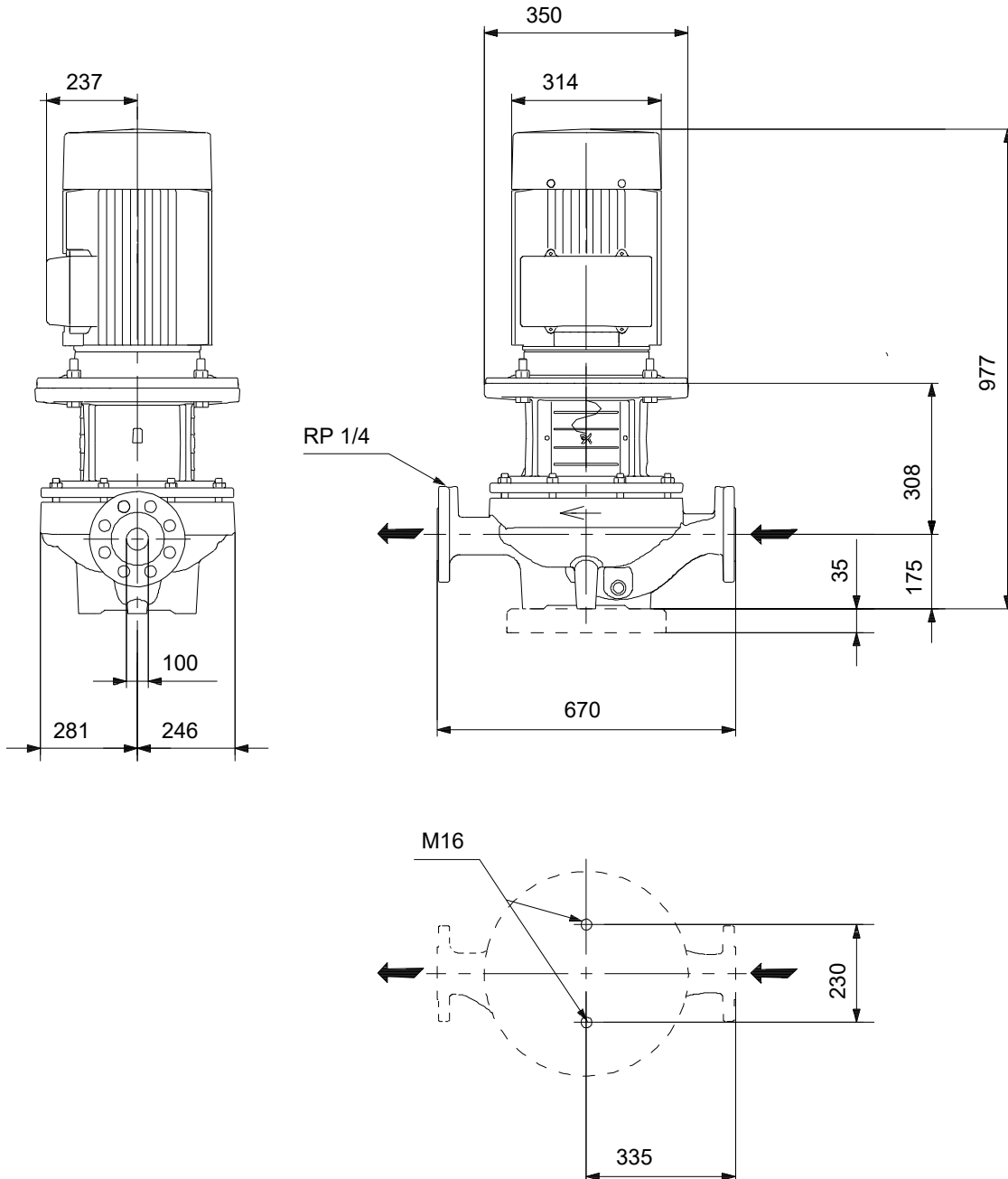

Note! All units are in [mm] unless others are stated.
Disclaimer: This simplified dimensional drawing does not show all details.

On request TP 100-250/4 A3-F-O-DAQF-NW3 50 Hz



IEC TP211 THERMALLY PROTECTED WHEN THE THERMISTORS ARE
CONNECTED TO AMPLIFIER RELAY FOR CONTROL OF MAIN SUPPLY
THERMISTORS PTC ACCORDING TO DIN 44082

Note! All units are in [mm] unless others are stated.

