

Submittal Data

PROJECT:	UNIT TAG:	QUANTITY:
REPRESENTATIVE: _____	TYPE OF SERVICE:	DATE: _____
ENGINEER:	SUBMITTED BY:	DATE:
CONTRACTOR:	APPROVED BY:	DATE:
	ORDER NO.:	DATE:



CMBE TWIN 3-93 I-U-C-J-D-A

CMBE TWIN is a high-efficiency booster system consisting of two Grundfos CMBE boosters connected in parallel, suitable for clean water supply and pressure boosting in domestic and commercial applications.

Note! Product picture may differ from actual product

Conditions of Service		Pump Data		Motor Data	
Liquid:	Water	Liquid temperature range:	0 .. 60 °C	Mains frequency:	50 Hz
Temperature:	20 °C	Maximum ambient temperature:	55 °C	Enclosure class:	IP55
Specific Gravity:	1.000	Shaft seal:	AVBE		
		Product number:	On request		

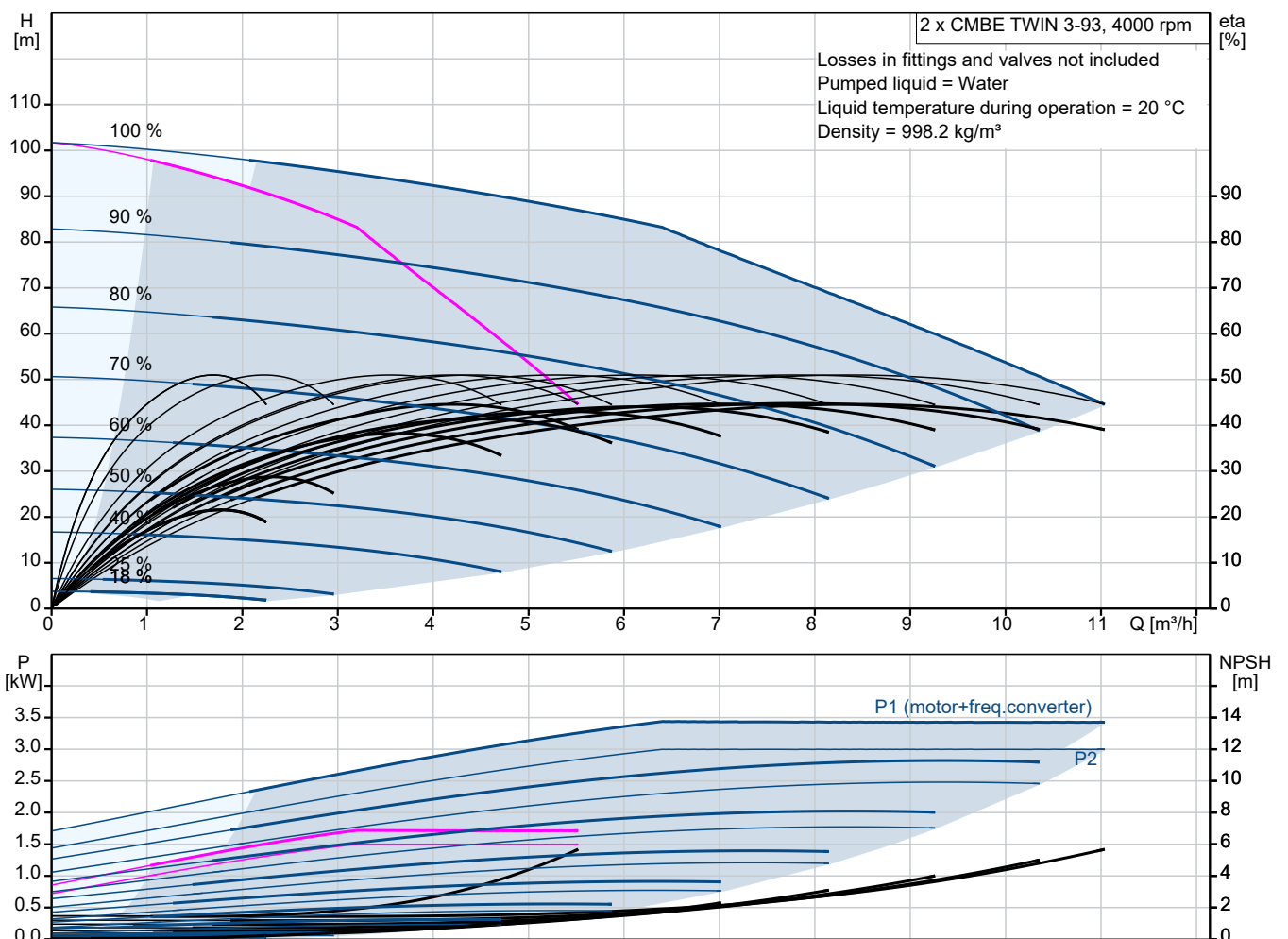

Submittal Data

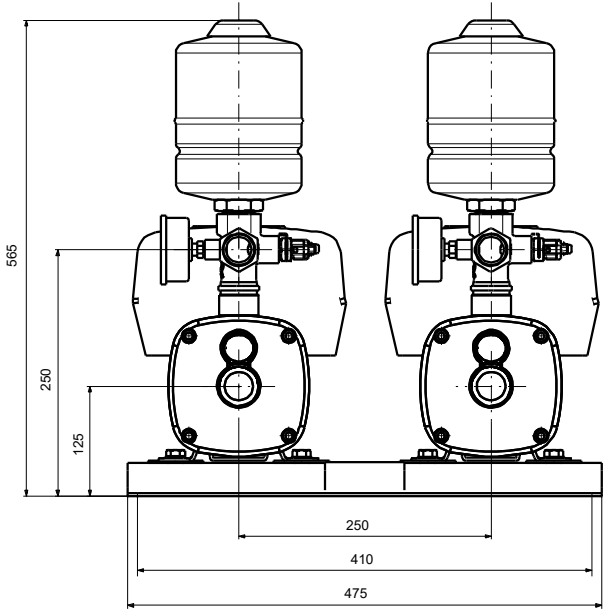
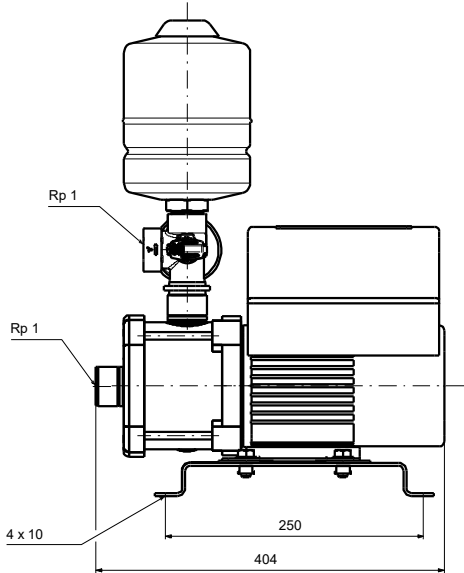

- Materials:**
- Pump housing: Stainless steel
 - Pump housing: AISI 304
 - Impeller: Stainless steel
 - Impeller: EN 1.4301
 - Impeller: AISI 304
 - Code for rubber: EPDM

Qty. Description

1 The Grundfos CMBE TWIN booster is a compact two-booster system for water supply in domestic and commercial applications.



Note! Product picture may differ from actual product

Product No.: On request

The integrated speed controller allows the CMBE TWIN booster to maintain constant pressure in the pipe system.

The CMBE TWIN booster offers parallel operation via cascade multipump operation. This feature ensures that the performance of the CMBE TWIN booster is automatically adapted to the consumption by switching pumps on or off and by changing the speed of the pumps in operation.

A pressure sensor monitoring changes in the water consumption signals the speed controller to change the motor speed. The system therefore runs as energy-efficiently as possible with the number of pumps required. The CMBE TWIN booster is very easy to install, and it is UL approved.

The CMBE TWIN booster consists of 2 units of CMBE booster which each include the following:

- five-way valve
- expansion tank
- pressure gauge
- pressure sensor
- a base frame
- a twin communication cable

The Grundfos CMBE TWIN booster requires no external motor protection.

The MGE motors incorporates thermal protection against slow overloading and blocking (TP 211 according to IEC 34-11).

The Grundfos CMBE TWIN booster is mainly used for domestic and light commercial water supply or booster systems.

NB:

Suction lift: maximum 1 m, including inlet pipe pressure loss at a liquid temperature of 20 °C (not self-priming).

On request CMBE TWIN 3-93 I-U-C-J-D-A 50 Hz

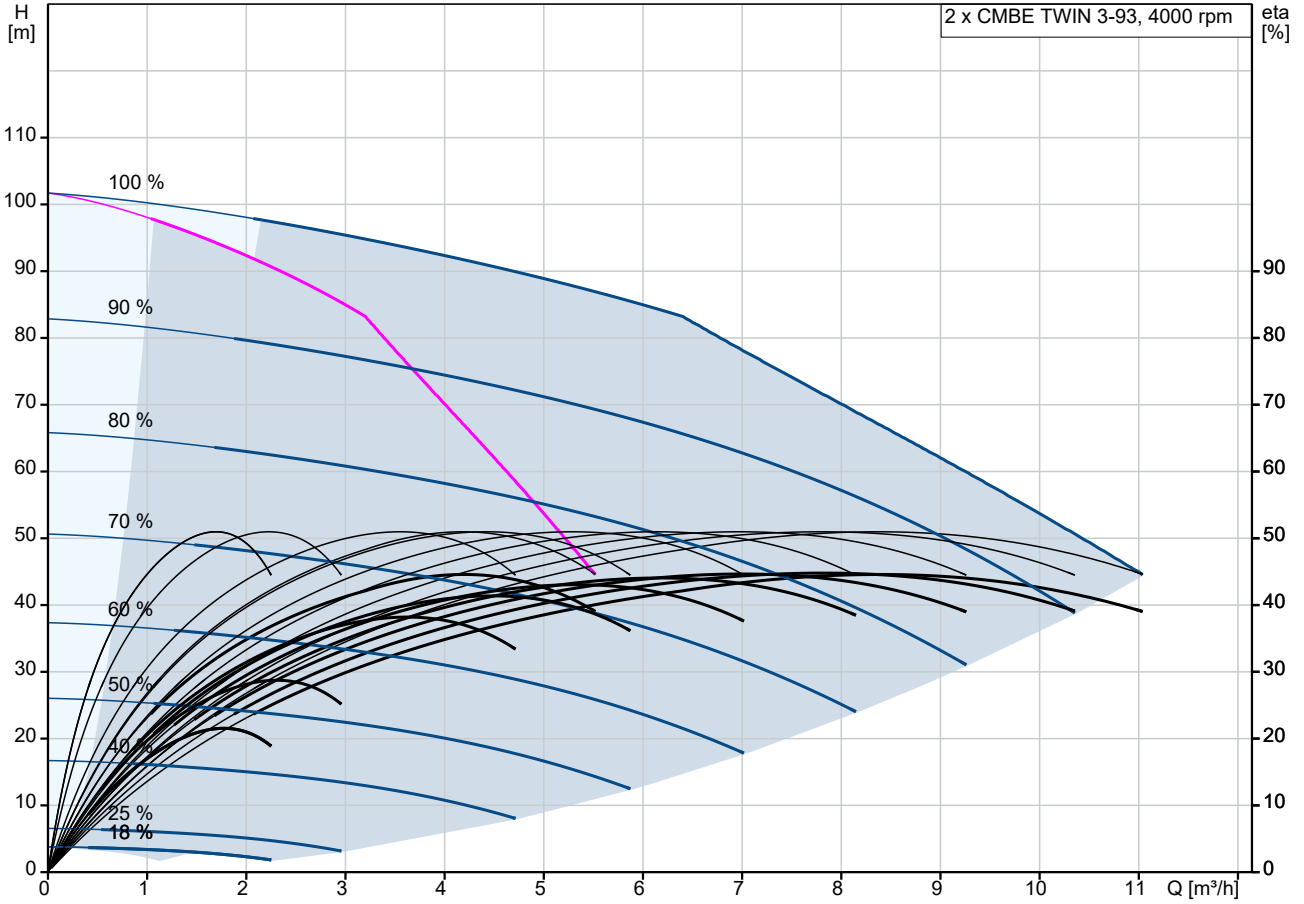

Losses in fittings and valves not included
Pumped liquid = Water
Liquid temperature during operation = 20 °C
Density = 998.2 kg/m³

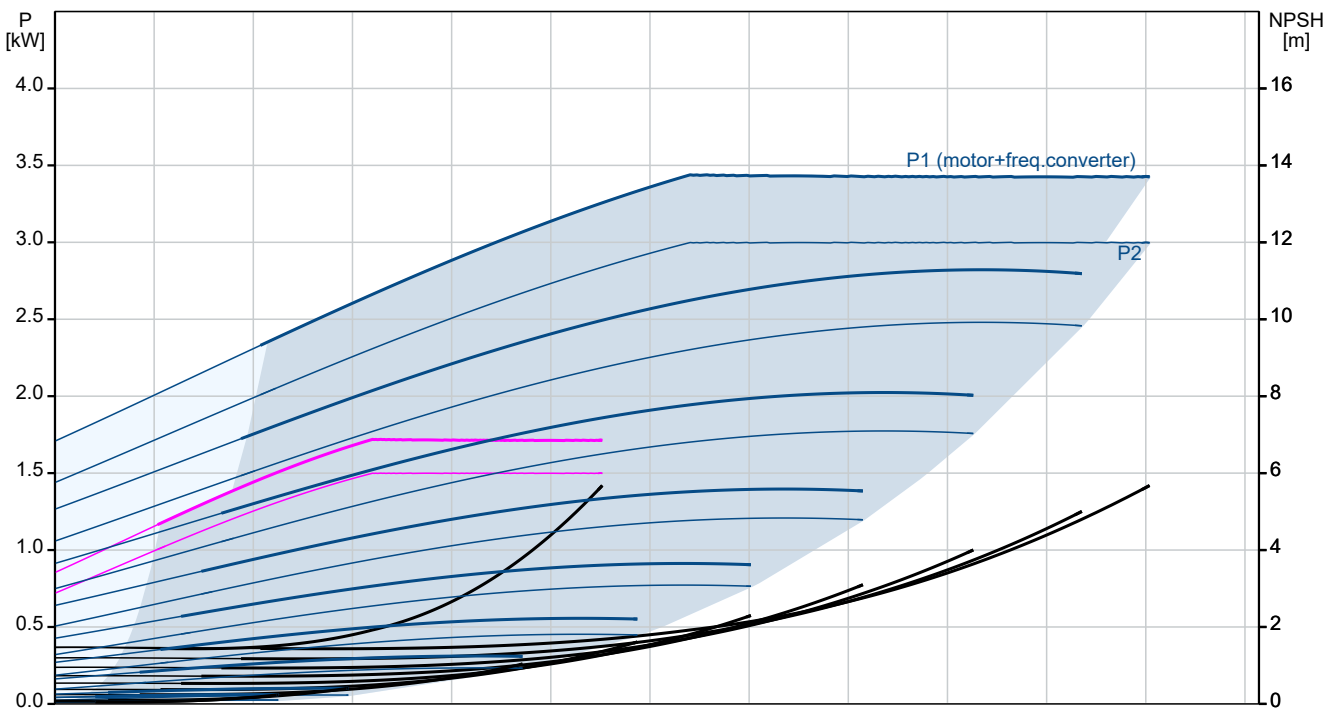

Description	Value
General information:	
Product name:	CMBE TWIN 3-93 I-U-C-J-D-A
Product No:	On request
EAN number:	On request
Technical:	
Pump speed on which pump data are based:	3868 rpm
Rated flow:	4.2 m³/h
Rated head:	66.3 m
Impellers:	6
Code for shaft seal:	AVBE
Approvals:	CE,EAC,CN ROHS EX,SEPRO,MORO,U
Approvals for drinking water:	UBA
Curve tolerance:	ISO9906:2012 3B
Number of pumps:	2
Model:	A
Start pressure:	Integrated Frequency converter
Tank volume:	4 l
Main pump type:	CMBE TWIN
Main pump product number:	98880399
Materials:	
Pump housing:	Stainless steel
Pump housing:	EN 1.4301
Pump housing:	AISI 304
Impeller:	Stainless steel
Impeller:	EN 1.4301
Impeller:	AISI 304
Code for rubber:	EPDM
Installation:	
Maximum ambient temperature:	55 °C
Maximum operating pressure:	10 bar
Pipe connection standard:	WHITWORTH THREAD RP
Pump inlet:	RP 1
Pump outlet:	RP 1
Pressure rating for connection:	PN 10
Liquid:	
Pumped liquid:	Water
Liquid temperature range:	0 .. 60 °C
Selected liquid temperature:	20 °C
Density:	998.2 kg/m³
Electrical data:	
Rated power - P2:	1.5 kW
Mains frequency:	50 Hz
Rated voltage:	1 x 200-240 V
Maximum current consumption:	18.2-15.2 A
Enclosure class (IEC 34-5):	IP55
Insulation class (IEC 85):	F
Length of cable:	5 m
Power plug:	FUSE
Controls:	
Type of connector:	No plug
Others:	
Net weight:	44.5 kg
Gross weight:	52.4 kg
Config. file no:	99546305
Country of origin:	DE
Custom tariff no.:	84137075

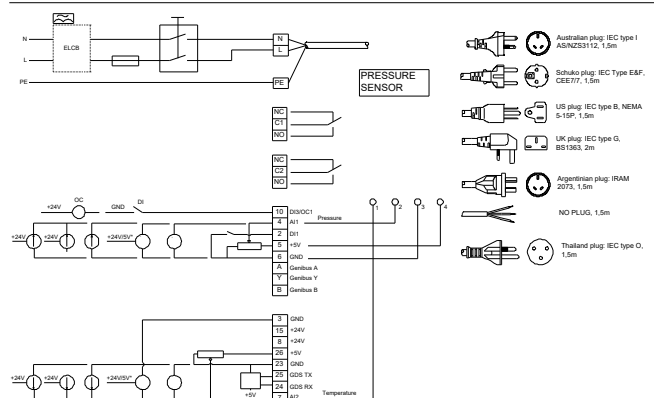
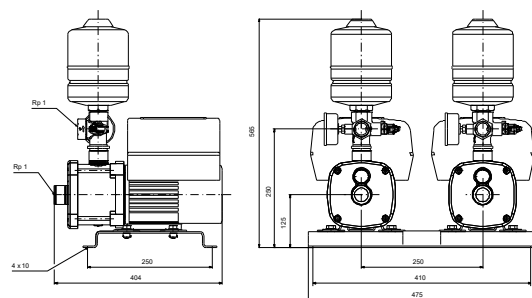
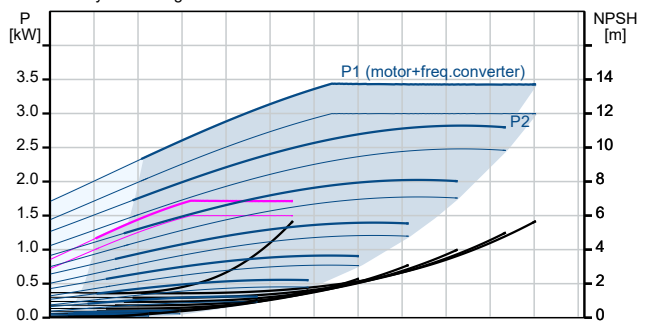
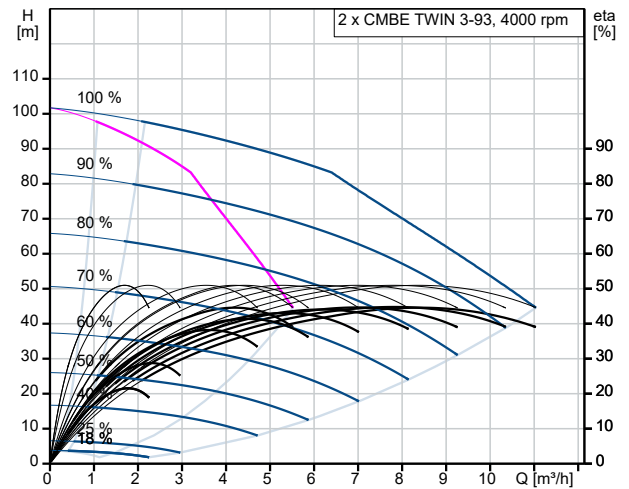



Company name:

Created by:

Phone:

Date:

28/11/2023

Description

Value

Environmental approvals:

WEEE

On request CMBE TWIN 3-93 I-U-C-J-D-A 50 Hz

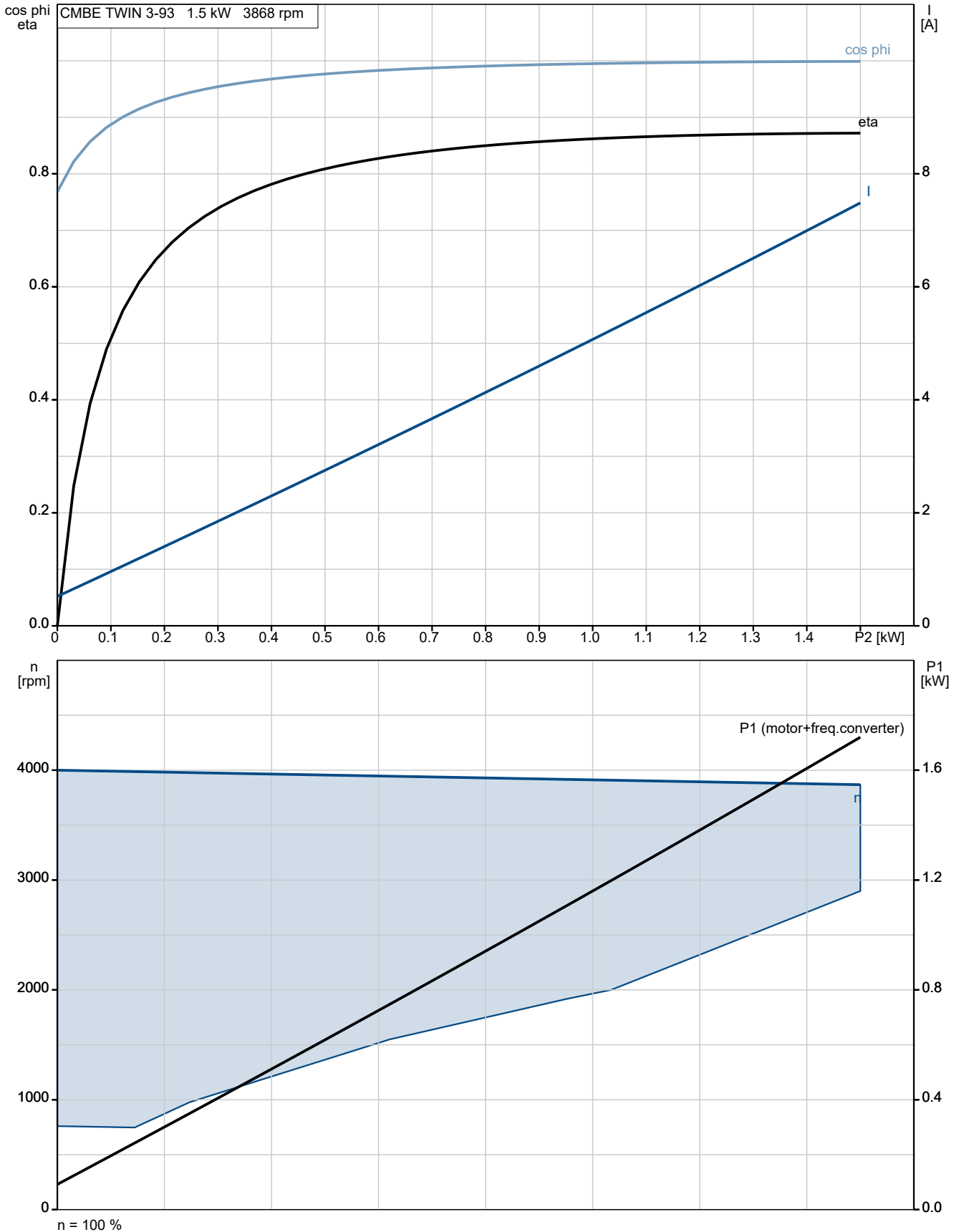

On request CMBE TWIN 3-93 I-U-C-J-D-A 50 Hz

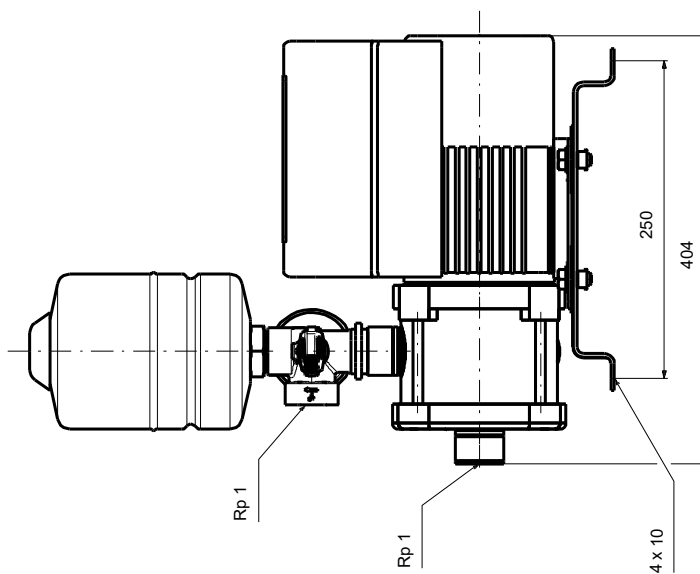
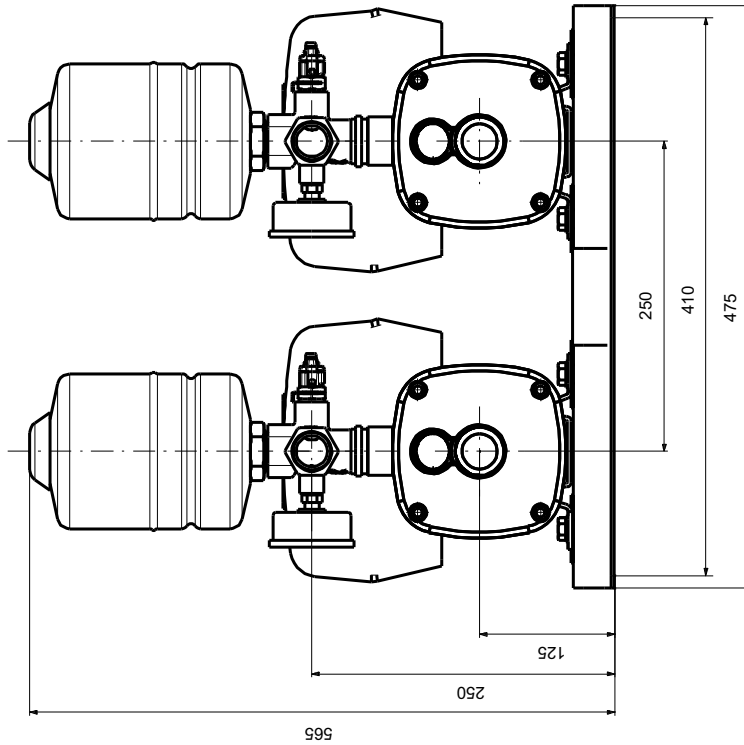

Note! All units are in [mm] unless others are stated.
Disclaimer: This simplified dimensional drawing does not show all details.

