

Submittal Data

PROJECT:	UNIT TAG:	QUANTITY:
REPRESENTATIVE: _____	TYPE OF SERVICE:	DATE: _____
ENGINEER:	SUBMITTED BY:	DATE:
CONTRACTOR:	APPROVED BY:	DATE:
	ORDER NO.:	DATE:



Hydro Solo-E CRIE 15-2

Hydro Solo-E is a fully-optimised booster system designed for systems where it is crucial to keep constant pressure. It features constant-pressure control, flow estimation and plug-and-pump installation.

Note! Product picture may differ from actual product

Conditions of Service	Pump Data	Motor Data
	Maximum operating pressure: 10 bar	Rated power - P2: 3 kW
	Liquid temperature range: 0 .. 60 °C	Rated voltage: 380-500 V
	Maximum ambient temperature: 50 °C	Mains frequency: 50 / 60 Hz
	Shaft seal: HQQE	Enclosure class: IP55
	Product number: On request	Insulation class: F
		Motor protection: ELEC
		Motor type: 100LA

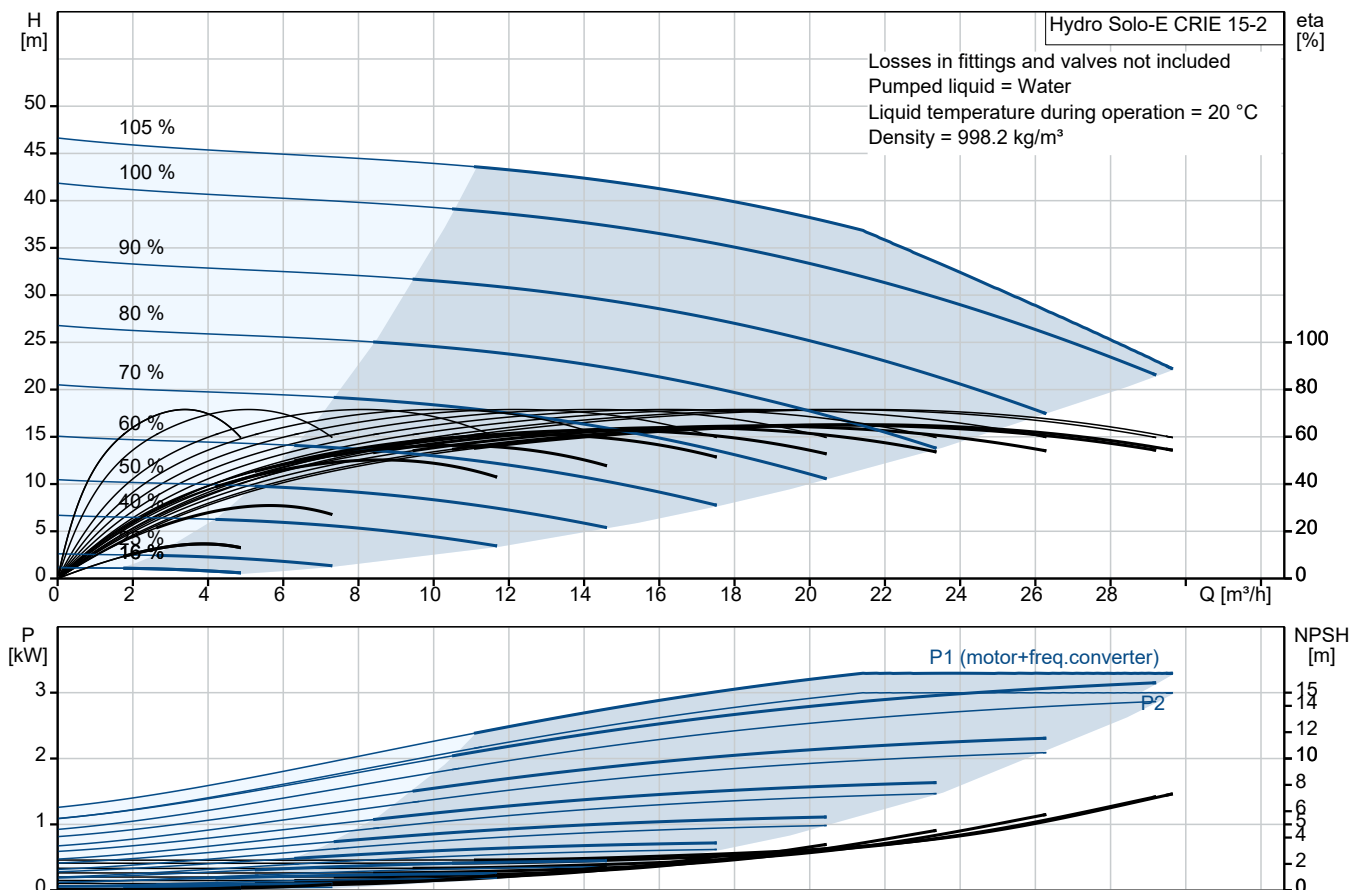

Submittal Data

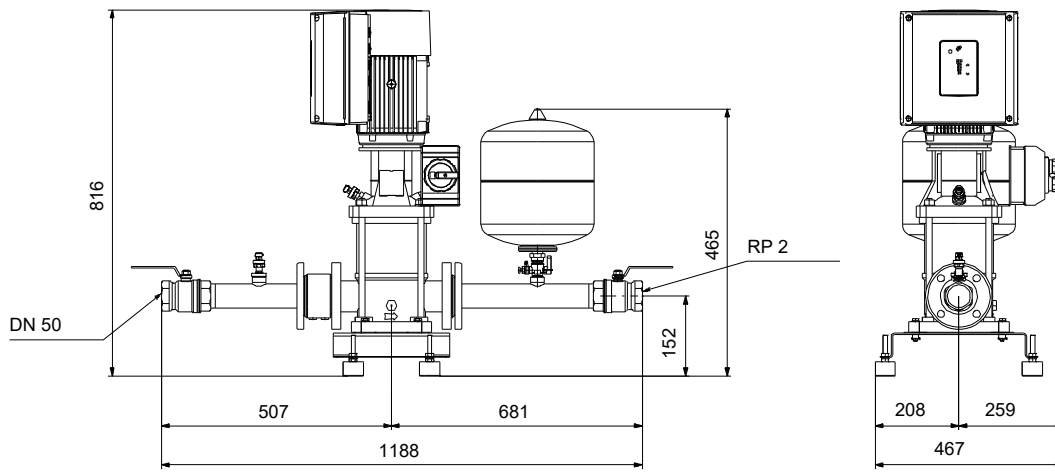

Materials:

Base: Stainless steel

Base: EN 1.4408

Base: AISI 316

Impeller: Stainless steel

Impeller: AISI 304

Impeller: EN 1.4301

Qty. Description

1 Hydro Solo-E CRIE 15-2



Note! Product picture may differ from actual product

Product No.: On request

Grundfos Hydro Solo-E booster set is a combined unit consisting of one Variable speed driven pump (CRE) fitted with:

isolating valve, non-return valve, inlet and discharge pipe, Discharge pressure transmitter, pressure gauge, diaphragm tank, inlet pressure transmitter, Base frame with vibration dampers and Main power switch.

The Booster system is factory configured and tested ready for constant pressure operation.

The system is preconfigured with the following features

- Constant pressure control
- Flow Estimation
- Dry-running protection
- Anti-cavitation protection
- Pump Running / Alarm Output replay configuration

The pump is fitted with an IEC-flanged three-phase MGE motor with frequency converter and PI-controller integrated in the motor terminal box. No additional motor protection is required as both motor and electronics are protected by integrated overload and temperature protection.

A Graphical display and control panel enables easy monitoring of system performance and setting of control parameters.

The Grundfos Eye indicator on the control panel provides visual indication of pump status: The control panel has

- "Power on": Motor is running (rotating green indicator lights) or not running (permanently green indicator lights)
- "Warning": Motor is still running (rotating yellow indicator lights) or has stopped (permanently yellow indicator lights)
- "Alarm": Motor has stopped (flashing red indicator lights).

Communication with the pump is possible by means of the Grundfos GO Remote (accessory). The remote control enables further settings as well as reading out of a number of parameters such as "Actual value", "Speed", "Power input" and total "Power consumption".

The terminal box has a number of inputs and outputs enabling the motor to be used in advanced applications where many inputs and outputs are required:

- Two dedicated digital inputs
- Three analog inputs, 0(4)-20 mA, 0-5 V, 0-10 V, 0.5 - 3.5 V
- 5 V voltage supply to potentiometer and sensor
- One analog output, 0-10 V, 0(4)-20 mA
- Two configurable digital inputs or open-collector outputs
- Two Pt100/Pt1000 inputs
- LiqTec, dry-running protection sensor input
- Grundfos Digital Sensor input and output

Qty.	Description
1	<p data-bbox="564 338 1086 461">24 V voltage supply for sensors Two signal relay outputs (potential-free contacts) GENibus connection Interface for Grundfos CIM fieldbus module.</p> <p data-bbox="196 551 668 613">Liquid: Liquid temperature range: 0 .. 60 °C</p> <p data-bbox="196 640 671 763">Technical: Rated flow: 20.5 m³/h Rated head: 38.3 m Code for shaft seal: HQQE</p> <p data-bbox="196 790 724 913">Materials: Base: Stainless steel EN 1.4408 AISI 316</p> <p data-bbox="196 913 724 1014">Impeller: Stainless steel EN 1.4301 AISI 304</p> <p data-bbox="196 1041 639 1312">Installation: Maximum ambient temperature: 50 °C Maximum operating pressure: 10 bar Standard for inlet connection: DIN Type of inlet connection: DIN Type of outlet connection: Rp Size of inlet connection: DN 50 Size of outlet connection: 2 inch Flange size for motor: FT130</p> <p data-bbox="196 1339 719 1675">Electrical data: Motor type: 100LA Rated power - P2: 3 kW Mains frequency: 50 / 60 Hz Rated voltage: 3 x 380-500 V Rated current: 5.80-4.80 A Cos phi - power factor: 0.91-0.86 Rated speed: 360-4000 rpm Enclosure class (IEC 34-5): IP55 Insulation class (IEC 85): F Motor No: 99026482</p> <p data-bbox="196 1702 608 1765">Tank: Volume of pressure tank: 18 l</p> <p data-bbox="196 1792 687 2007">Others: Net weight: 82.7 kg Gross weight: 103 kg Shipping volume: 0.6 m³ Danish VVS No.: 385551452 Country of origin: DE Custom tariff no.: 84137075</p>

On request Hydro Solo-E CRIE 15-2

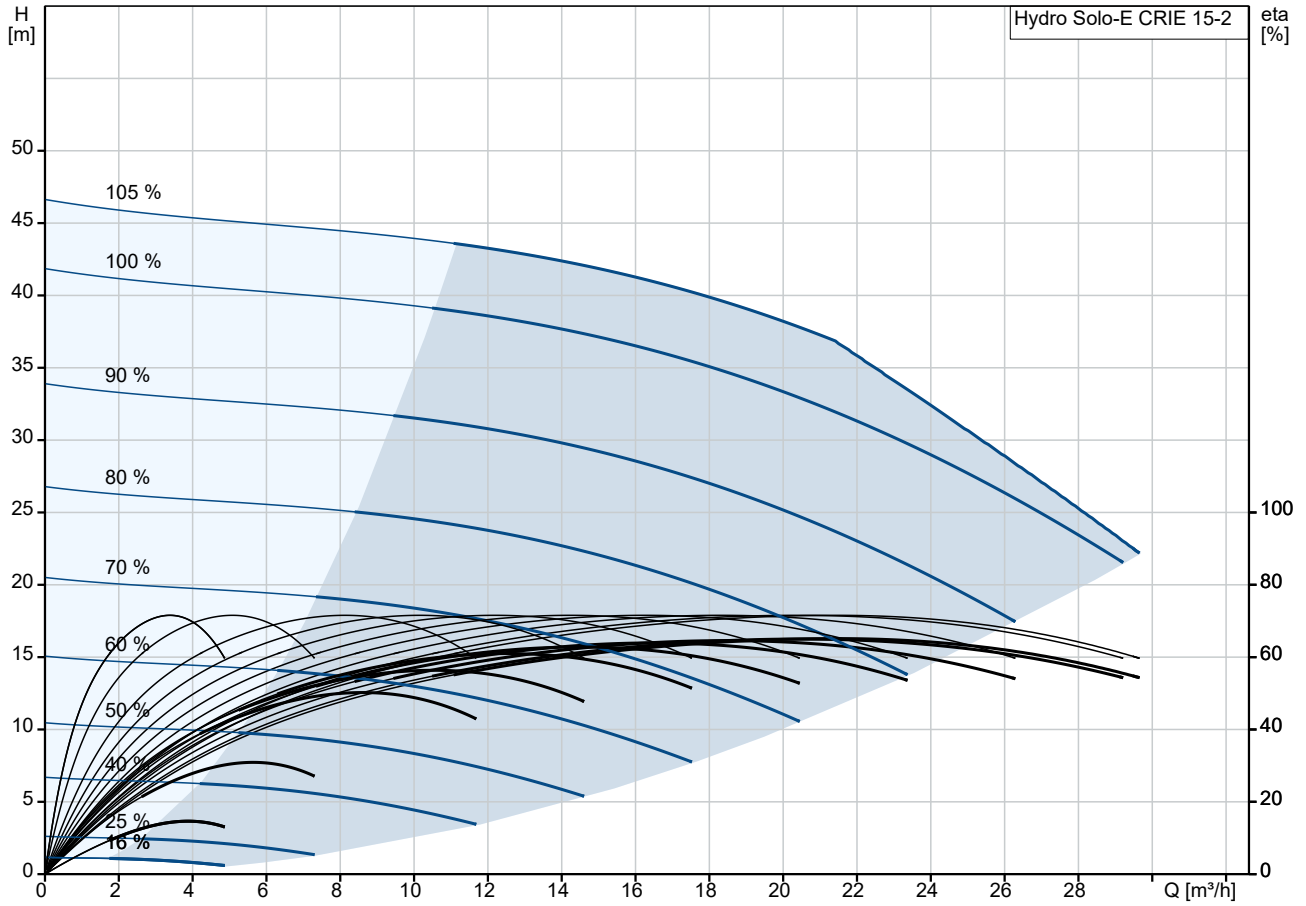

Losses in fittings and valves not included
 Pumped liquid = Water
 Liquid temperature during operation = 20 °C
 Density = 998.2 kg/m³

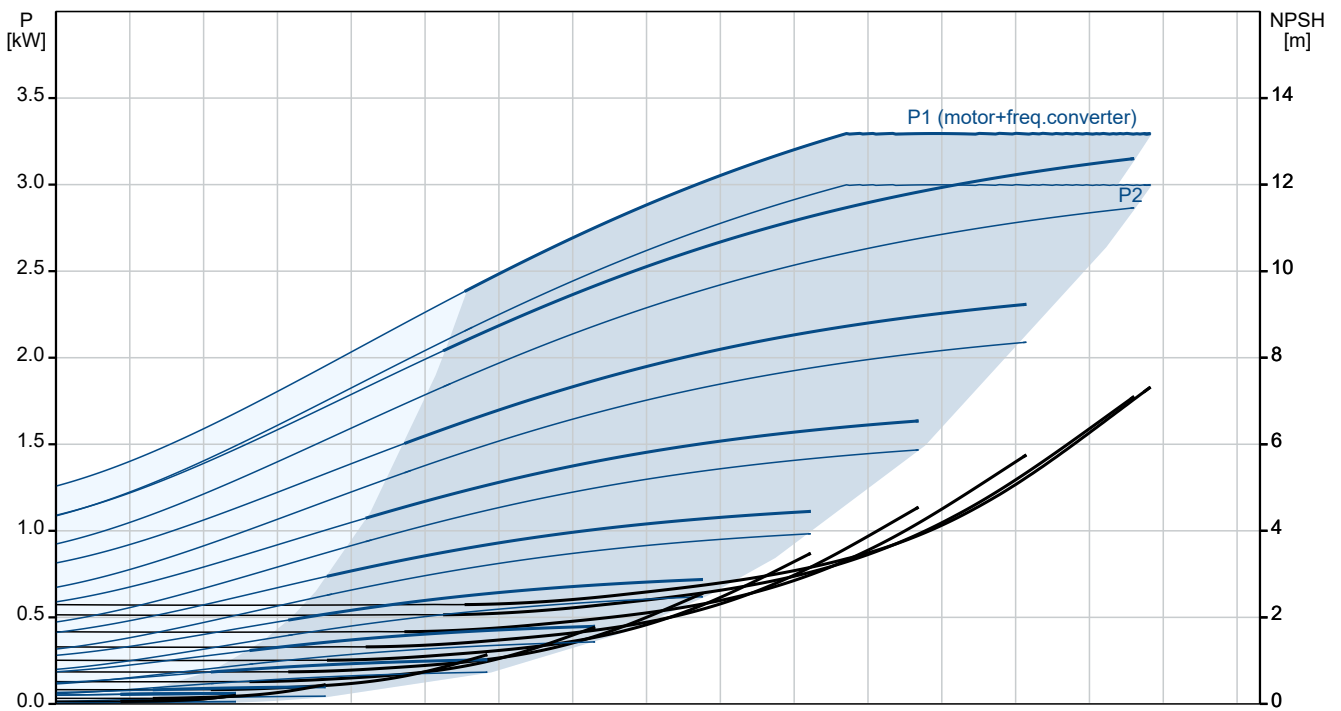

Description	Value
General information:	
Product name:	Hydro Solo-E CRIE 15-2
Product No:	On request
EAN number:	On request
Technical:	
Rated flow:	20.5 m³/h
Rated head:	38.3 m
Stages:	2
Impellers:	2
Code for shaft seal:	HQQE
Pump No:	99367394
Materials:	
Base:	Stainless steel
Base:	EN 1.4408
Base:	AISI 316
Impeller:	Stainless steel
Impeller:	EN 1.4301
Impeller:	AISI 304
Installation:	
Maximum ambient temperature:	50 °C
Maximum operating pressure:	10 bar
Standard for inlet connection:	DIN
Type of inlet connection:	DIN
Type of outlet connection:	Rp
Size of inlet connection:	DN 50
Size of outlet connection:	2 inch
Flange size for motor:	FT130
Liquid:	
Liquid temperature range:	0 .. 60 °C
Electrical data:	
Motor type:	100LA
Rated power - P2:	3 kW
Mains frequency:	50 / 60 Hz
Rated voltage:	3 x 380-500 V
Rated current:	5.80-4.80 A
Cos phi - power factor:	0.91-0.86
Rated speed:	360-4000 rpm
Enclosure class (IEC 34-5):	IP55
Insulation class (IEC 85):	F
Built-in motor protection:	ELEC
Motor No:	99026482
Controls:	
Control type:	ME
Tank:	
Volume of pressure tank:	18 l
Others:	
Net weight:	82.7 kg
Gross weight:	103 kg
Shipping volume:	0.6 m³
Product range:	International
Config. file no:	99367355
Danish VVS No.:	385551452
Country of origin:	DE
Custom tariff no.:	84137075

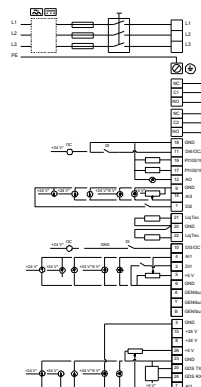
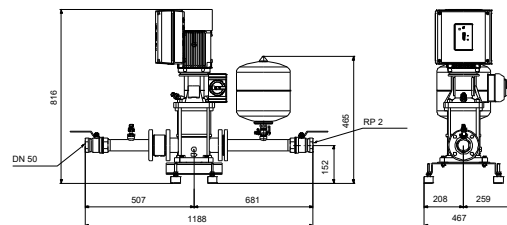
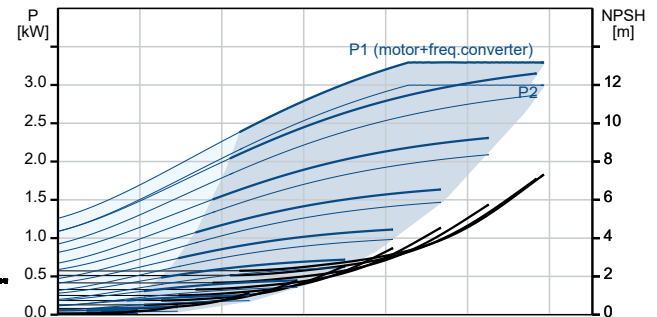
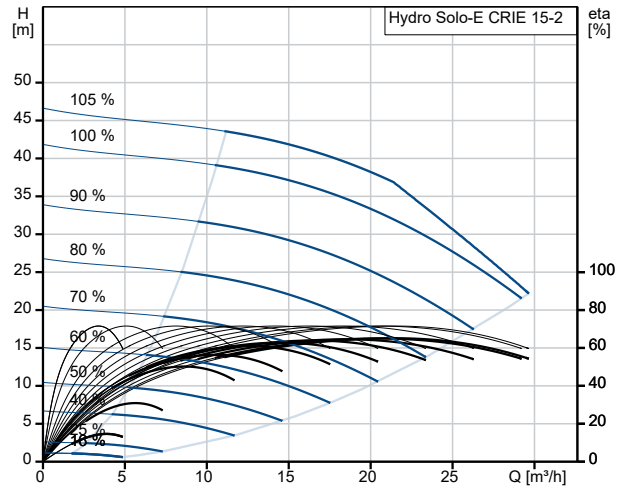

On request Hydro Solo-E CRIE 15-2

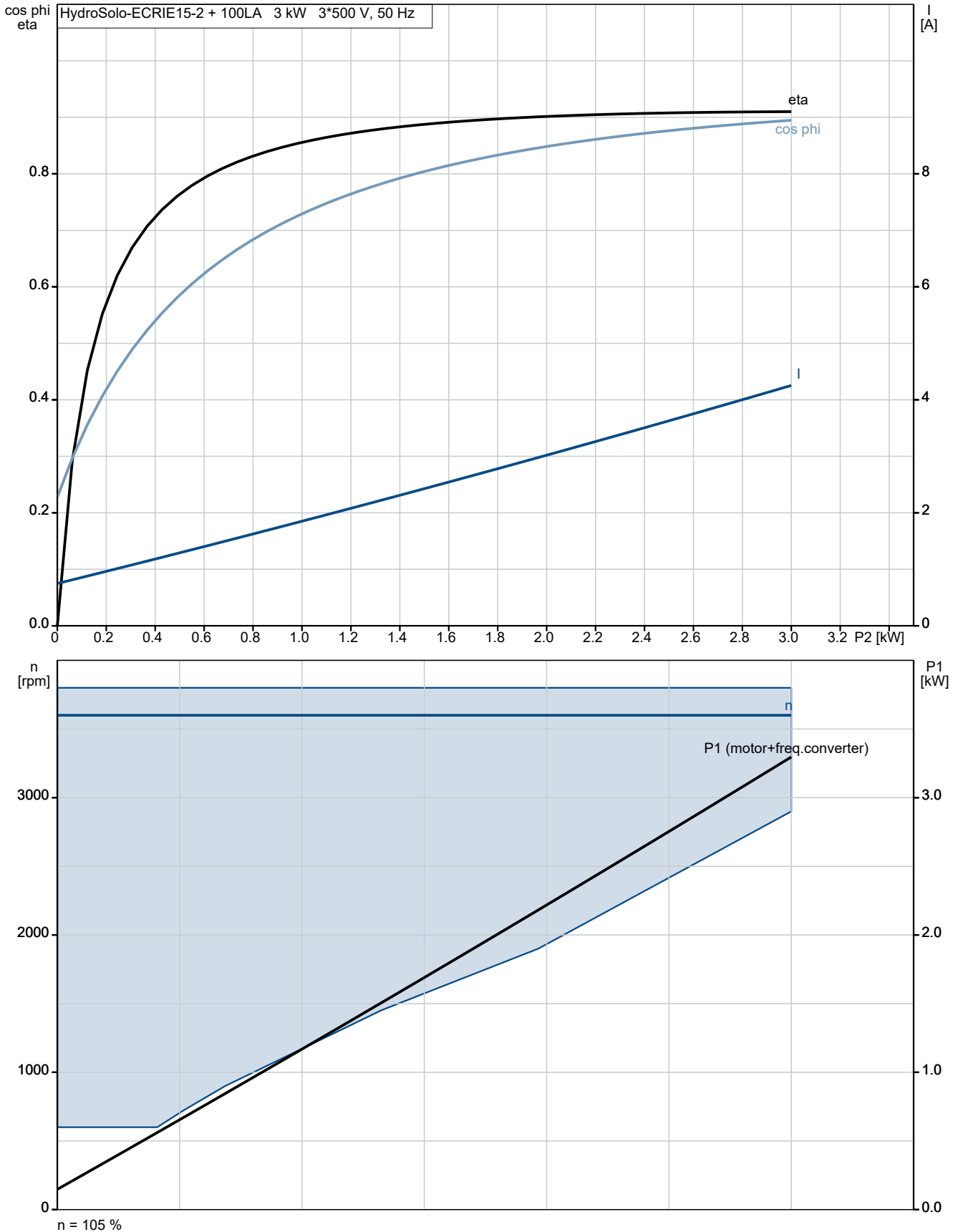

On request Hydro Solo-E CRIE 15-2

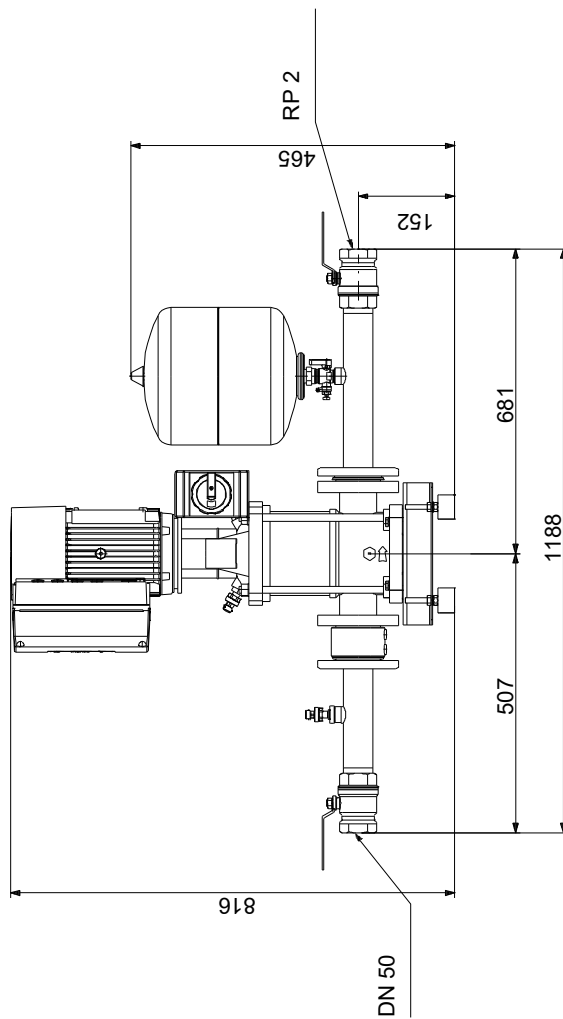
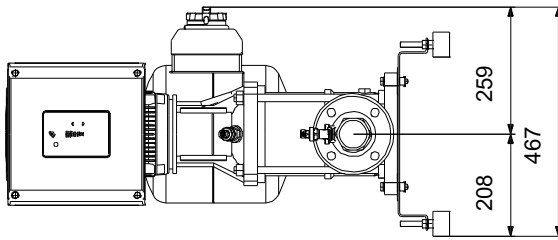

Note! All units are in [mm] unless others are stated.
Disclaimer: This simplified dimensional drawing does not show all details.

On request Hydro Solo-E CRIE 15-2

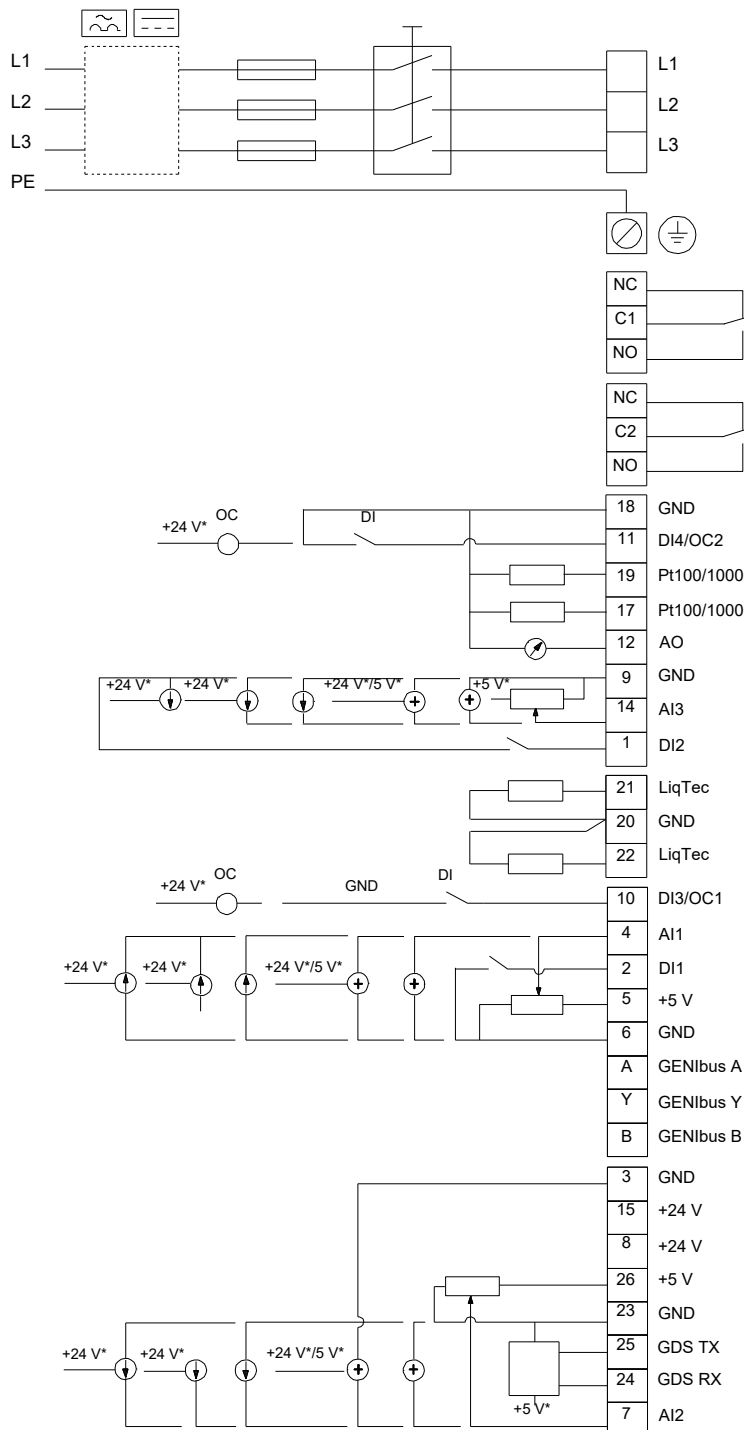

Note! All units are in [mm] unless others are stated.

