

Vorgabedaten

PROJEKT:	UNIT TAG:	MENGE:
ANSPRECHPARTNER: _____	SERVICELEISTUNG:	DATUM: _____
INGENIEUR/TECHNIKER:	VORGEGEBEN VON:	DATUM:
AUFTRAGNEHMER:	BESTELLNUMMER:	DATUM:



DMH 770-10 B-PV/T/T-X-E1B5B5XEMAG

Kolbenmembranpumpen mit externem Motor oder Hydraulikantrieb

Hinweis! Abbildung kann vom Produkt abweichen.

Servicebedingungen	Pumpendaten	Motordaten
Fördermedium: Wasser	Medientemperaturbereich: -10 .. 60 °C	Bemessungsspannung: 230/400 V
Temperatur: 20 °C	Produktnummer: auf Anfr.	Netzfrequenz: 50 Hz
Relative Dichte: 1.000		Schutzart: IP55

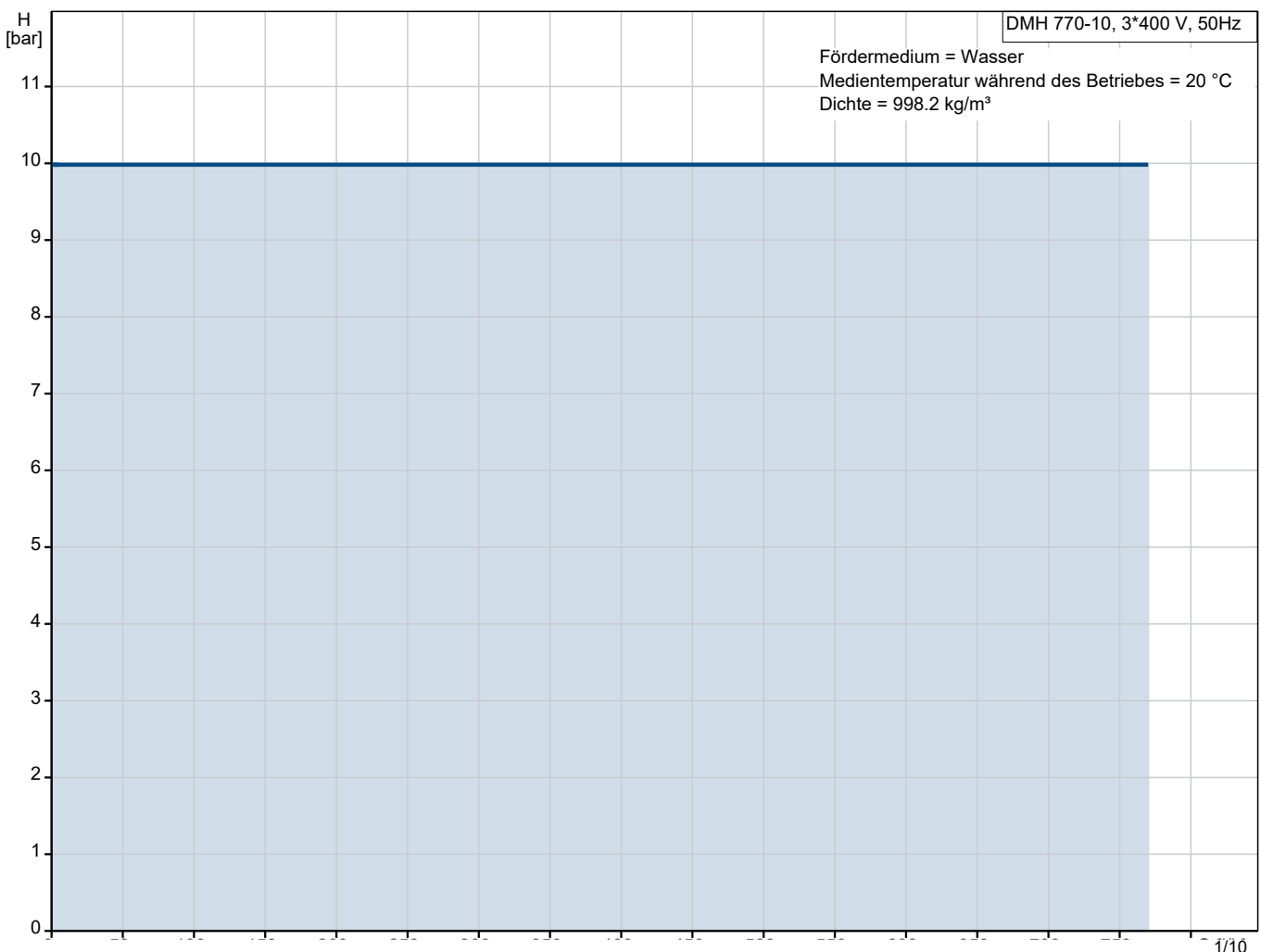

Vorgabedaten

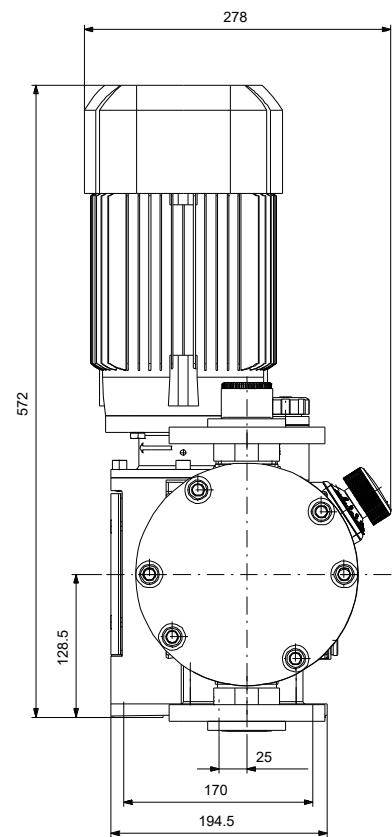
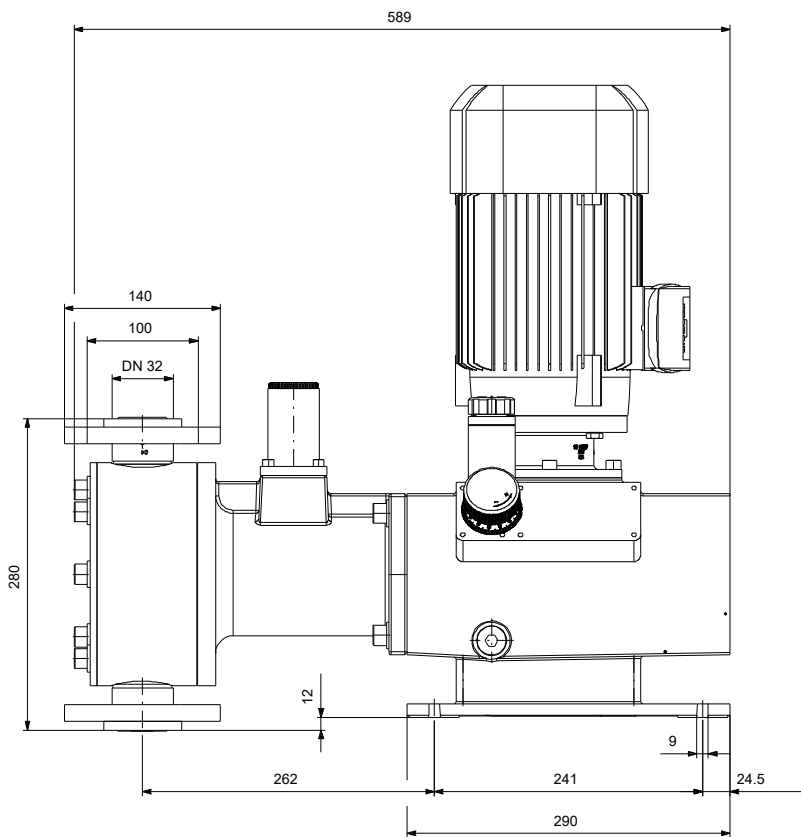

Werkstoffe:
Pumpengehäuse: Aluminium

Anz.	Beschreibung
------	--------------

1	DMH 770-10 B-PV/T/T-X-E1B5B5XEMAG
---	--



Hinweis! Abbildung kann vom Produkt abweichen.

Produktnr.: auf Anfr.

The pump of the DMH series is a versatile positive displacement diaphragm dosing pump.

The diaphragm is coupled hydraulically via a precise gear-eccenter-tapet-system to a high efficiency AC motor. The dosing capacity is adjusted by varying the stroke length at the stroke adjustment knob in the ratio 1 to 10.

The range is highly versatile, it covers a wide flow range and offers a variety of dosing head sizes, materials and accessories. Customers worldwide have enjoyed years of trouble-free operation from their DMH pumps.

The Grundfos DMH range is a series of extremely strong, robust pumps for applications requiring reliable dosing capability, such as process engineering.

The liquid end is composed of:

- Dosing head
- PTFE diaphragm
- Ball valves

Other features:

- Robust industrial pump with aluminium or cast iron enclosure
- Easy to install and operate design
- Long life PTFE diaphragm
- Optimum capacity and stroke frequency graduation
- Dosing flow variation $\pm 1.5\%$ (FS), linearity $\pm 2\%$ (FS)

Applies only to pumps with: ATEX certification

The dosing pump DMH 25x is certified according to the ATEX guideline RL 94/9/EC for non-electrical operating supplies.

The motor versions EEx e and EEx de defined by Grundfos are certified by the manufacturers according to ATEX guidelines for electrical operating supplies. The motor type plate is labelled according to ATEX.

The ATEX approved DMH pumps are available in a variety of configurations - some can be used for dosing combustible liquids.

Electronics features:

Applies only to pumps with control variant: AR

Etron Profi microprocessor electronics, direct attached to motor:

- Stroke frequency adjustable from 1 stroke/min to maximum stroke frequency
- Pulse control with multiplier and divisor
- Analogue signal control 0/4-20 mA
- Level control with input for two level signals.
- Pulse, analogue and remote on/off input
- Analogue output

Projekt:

Referenznummer:

Kunde:

Kundennummer:

Kontakt:

Anz.	Beschreibung
1	<ul style="list-style-type: none"> - Alarm relay output -Stroke output -Input for dosing controller and diaphragm monitoring sensor <p>Applies only to pumps with control variant: D3; D6</p> <ul style="list-style-type: none"> - Automatic adjustment of stroke length via direct drive control or mA-input signal - For further specifications please refer to servomotor <p>Art der Steuerung: Type of connector: No plug Type of control variant: Standardausführung Frequency converter: Nicht für den Frequenzumrichterbetrieb vorbereitet</p> <p>Fördermedium: Fördermedium: Wasser Medientemperaturbereich: -10 .. 60 °C Medientemperatur während des Betriebs: 20 °C Dichte: 998.2 kg/m³</p> <p>Technische Daten: Nominal flow rate at 50 Hz: 770 l/h Number of dosing heads: 1 Zulassungen: CE,EAC,CNROHSEX Non return valve type, inlet pump 1: Standardausführung Non return valve type, outlet pump 1: Standardausführung Max. Viskosität: 50 mPas</p> <p>Werkstoffe: Pumpengehäuse: Aluminium Dosing head, pump 1: Plastic PVDF</p> <p>Ventilkugel: Verbundwerkstoff PTFE</p> <p>Ventilsitz: Kunststoff PVDF</p> <p>Ventil-Dichtung: PTFE Verbundwerkstoff</p> <p>Installation: Max operating pressure at 50 Hz: 10 bar Maximum permissible inlet pressure: 0.8 bar Anschlusstyp Eintritt: Welding Anschlusstyp Austritt: Welding Größe des Saugstutzens: 40 Größe des Druckanschlusses: 40</p> <p>Elektrische Daten: Leistungsaufnahme P1: 1 kW Netzfrequenz: 50 Hz Maximale Frequenz: 50 Hz Bemessungsspannung: 3 x 230/400 V Schutzart (gemäß IEC 34-5): IP55 Mit Kabel (ja/nein): nein Netzstecker: Ohne Stecker</p>



Name des Unternehmens:

Angelegt von:

Telefon:

Datum:

17.01.2024

Projekt:

Referenznummer:

Kunde:

Kundennummer:

Kontakt:

Anz.	Beschreibung
1	Sonstiges: Nettogewicht: 65 kg Bruttogewicht: 73.7 kg Versandvol.: 0.995 m ³ Diaphragm Leakage Detection: nein



Name des Unternehmens:

Angelegt von:

Telefon:

Datum:

17.01.2024

Projekt:

Referenznummer:

Kunde:

Kundennummer:

Kontakt:

auf Anfr. DMH 770-10 B-PV/T/T-X-E1B5B5XEMAG 50 Hz

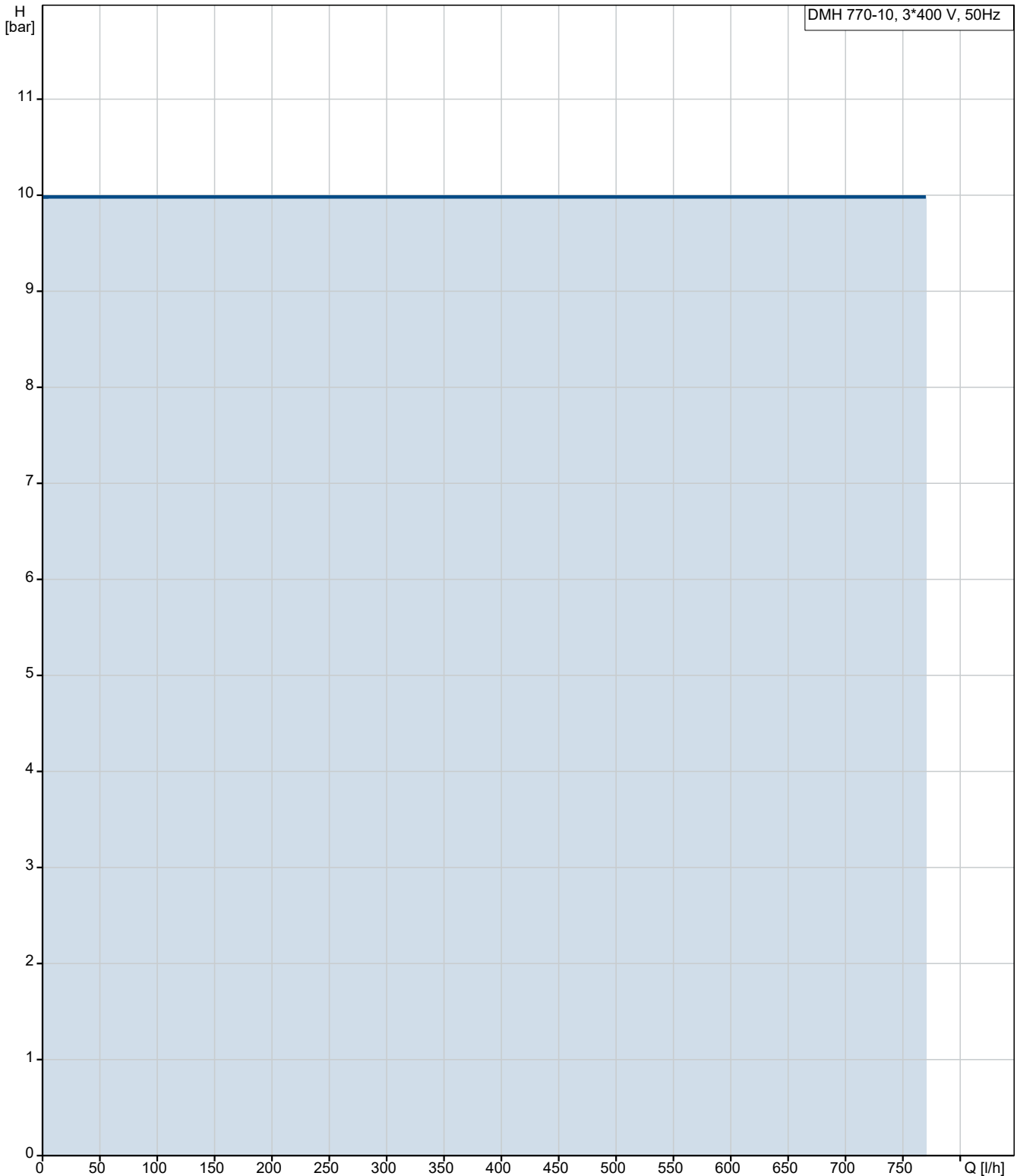

Fördermedium = Wasser

Medientemperatur während des Betriebes = 20 °C

Dichte = 998.2 kg/m³

Projekt:

Referenznummer:

Kunde:

Kundennummer:

Kontakt:

Beschreibung	Daten
Allgemeine Informationen:	
Produktbezeichnung:	DMH 770-10 B-PV/T/T-X-E1B5B5XEMAG
Produktnummer:	auf Anfr.
EAN-Nummer:	auf Anfr.
Technische Daten:	
Nominal flow rate at 50 Hz:	770 l/h
Number of dosing heads:	1
Zulassungen:	CE,EAC,CNROHSEX
Non return valve type, inlet pump 1:	Standardausführung
Non return valve type, outlet pump 1:	Standardausführung
Max. Viskosität:	50 mPas
Werkstoffe:	
Pumpengehäuse:	Aluminium
Dosing head, pump 1:	Plastic
Dosing head, pump 1:	PVDF
Ventilkugel:	Verbundwerkstoff
Ventilkugel:	PTFE
Ventilsitz:	Kunststoff
Ventilsitz:	PVDF
Ventil-Dichtung:	PTFE
Ventil-Dichtung:	Verbundwerkstoff
Installation:	
Max operating pressure at 50 Hz:	10 bar
Maximum permissible inlet pressure:	0.8 bar
Anschlussstyp Eintritt:	Welding
Anschlussstyp Austritt:	Welding
Größe des Saugstutzens:	40
Größe des Druckanschlusses:	40
Fördermedium:	
Fördermedium:	Wasser
Medientemperaturbereich:	-10 .. 60 °C
Medientemperatur während des Betriebs:	20 °C
Dichte:	998.2 kg/m ³
Elektrische Daten:	
Leistungsaufnahme P1:	1 kW
Netzfrequenz:	50 Hz
Maximale Frequenz:	50 Hz
Bemessungsspannung:	3 x 230/400 V
Schutzart (gemäß IEC 34-5):	IP55
Mit Kabel (ja/nein):	nein
Netzstecker:	Ohne Stecker
Art der Steuerung:	
Type of connector:	No plug
Type of control variant:	Standardausführung
Frequenzumrichter:	Nicht für den Frequenzumrichterbetrieb vorbereitet
Sonstiges:	
Nettogewicht:	65 kg
Bruttogewicht:	73.7 kg

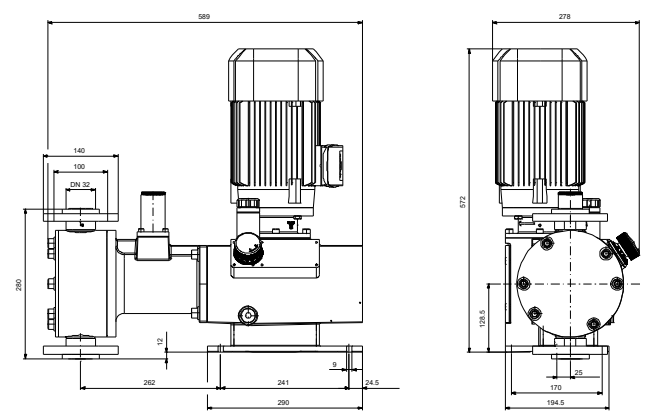
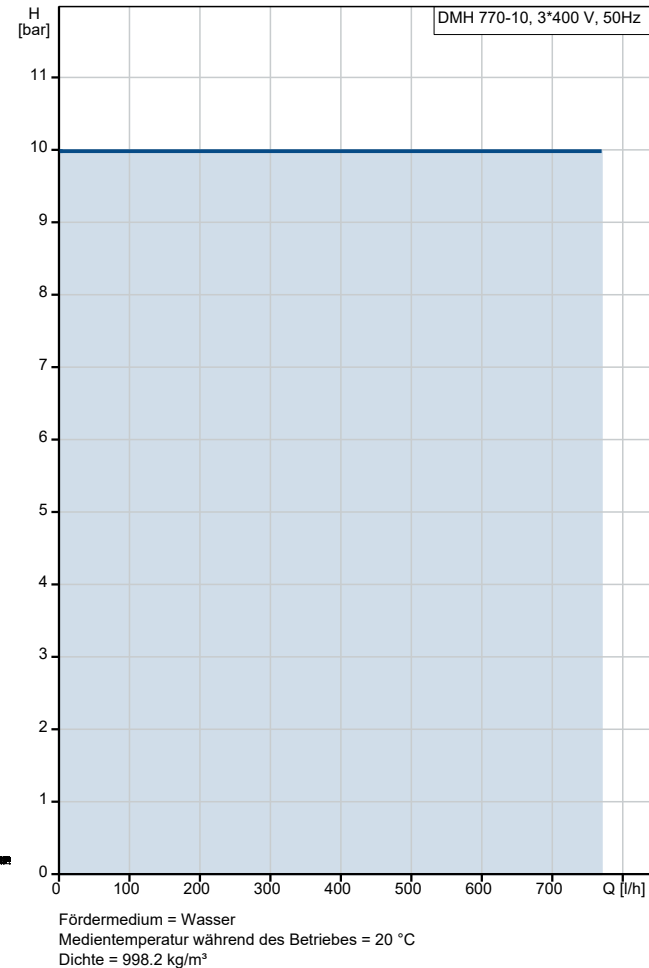



Name des Unternehmens:

Angelegt von:

Telefon:

Datum:

17.01.2024

Projekt:

Referenznummer:

Kunde:

Kundennummer:

Kontakt:

Beschreibung	Daten
Versandvol.:	0.995 m ³
Diaphragm Leakage Detection:	nein

auf Anfr. DMH 770-10 B-PV/T/T-X-E1B5B5XEMAG 50 Hz

